

LV power circuit breaker and switch-disconnectors

Masterpact NW Direct current 1000 to 4000 A

Catalogue

2002



Merlin Gerin
Square D

Schneider
 **Electric**

Get more with the world's Power & Control specialist

General contents

Presentation 2

Functions and characteristics 5

Dimensions and connection 25

Electrical diagrams 37

Installation recommendations 43

Additional characteristics 55

Catalogue numbers 59

Masterpact circuit breakers are used to protect and control low-voltage distribution systems. They may be installed in main LV switchboards (incoming units, main and secondary outgoers)

Masterpact DC devices are available in fixed and drawout versions. They use the proven technology of the AC range and offer the same advantages:

- 3 ratings: 1000, 2000 and 4000 A
- 2 performance levels: N and H
- a circuit-breaker version including a control unit designed to protect the power circuits and loads
- a switch (unprotected) version.

Auxiliaries

All auxiliaries designed for Masterpact AC devices may be used on the DC versions.

Masterpact circuit breaker
(circuit breaker: blue numbers, chassis: red numbers)

- 1 OFF pushbutton
- 2 ON pushbutton
- 3 racking-handle storage
- 4 racking interlock
- 5 closing mechanism charging handle
- 6 operation counter
- 7 keylock locking
- 8 padlock locking
- 9 reset pushbutton
- 10 "connected / test / disconnected" position indication
- 11 racking-handle port
- 12 shutter position indication and locking
- 13 operating mechanism charged and "ready to close" indication:

- spring charged
- spring discharged

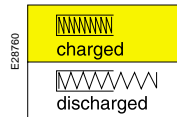

14 main contact position indication:

- OFF
- ON

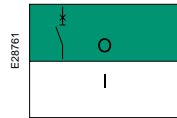

15 fault trip indication and reset button.

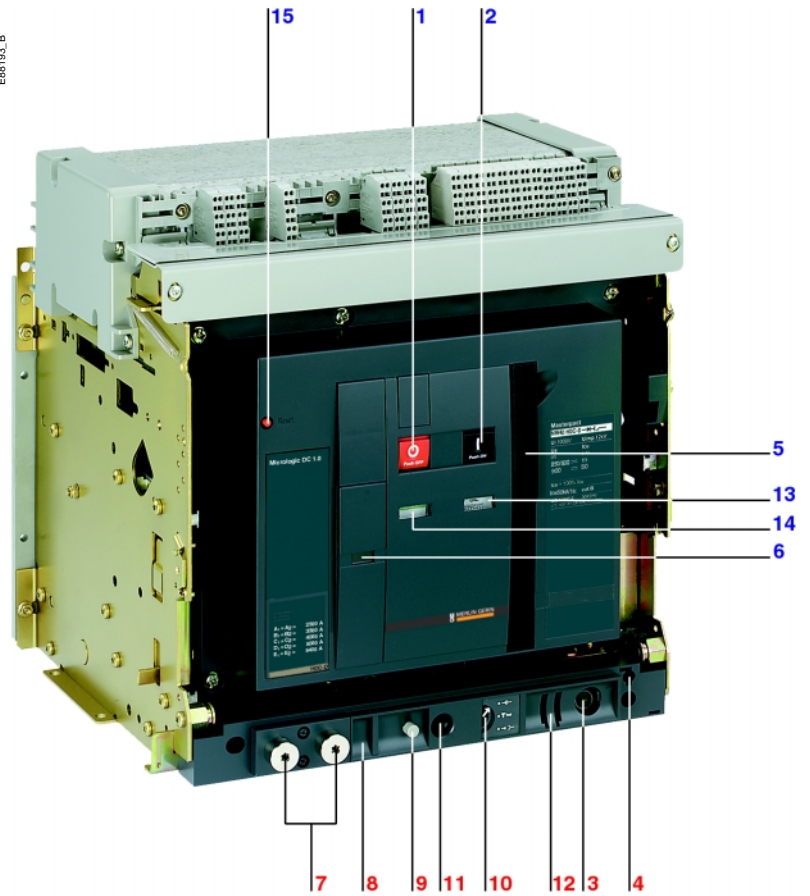

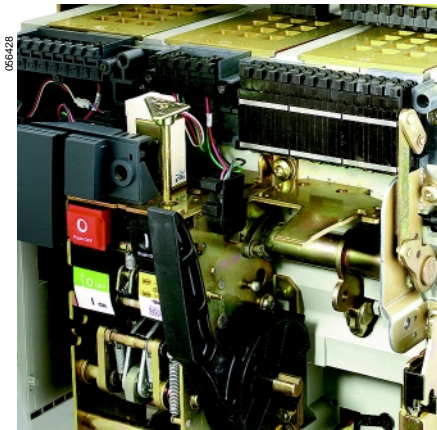

Safety and reliability

- reduced, simple maintenance (main contacts easily accessible, with wear indication)
- class II front face insulation
- positive contact indication
- auxiliaries are installable on site without adjustments
- automatic opening of circuit breaker before racking (connection or disconnection)
- T2 tropicalisation as standard.

Stored energy operating mechanism

Masterpact circuit breakers use energy stored in springs for fast opening and closing. The spring mechanism is charged either manually by pumping a handle six times or electrically by a motor. Opening and closing can be initiated either from pushbuttons on the front of the circuit breaker or by remote control.

Common auxiliaries from 1000 to 4000 A

Auxiliaries

- accessible from the front in a compartment insulated from the power circuits
- secured by a single screw
- adjustment-free
- installable on site.

Device identification

NW 20 N DC-C

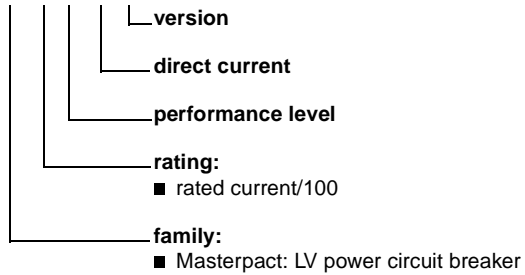

Presentation	2
Types of DC distribution systems	6
Selection of a DC circuit breaker	6
Pole arrangements	7
Circuit breakers and switch-disconnectors	8
NW10 to NW40	8
Micrologic control units	10
Micrologic DC 1.0	10
Current protection	11
Communication	12
COM option in Masterpact	12
Overview of functions	13
Masterpact in a communication network	14
Locking	16
On the device	16
On the chassis	17
Indication contacts	18
Remote operation	20
Remote ON / OFF	20
Remote tripping	23
Accessories	24
Dimensions and connection	25
Electrical diagrams	37
Installation recommendations	43
Additional characteristics	55
Catalogue numbers	59

Selection of a DC circuit breaker is based on the following criteria:

- the type of DC distribution system, which determines the required version
- the rated current, which determines the circuit breaker rating
- the rated voltage, which determines the number of series-connected poles required for breaking
- the maximum short-circuit current at the point of installation, which determines the breaking capacity of the circuit breaker.

Three types of DC distribution systems are encountered. The required operational voltage and the type of distribution system determine the number of poles required for breaking.

Distribution system no. 1: isolated

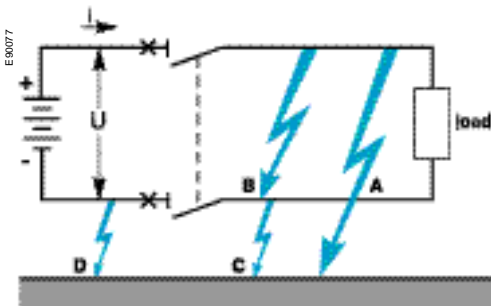

The source is isolated from earth

Fault B

Isc maximum.

Both polarities (positive and negative) of the source are concerned by the fault.

Fault A or C

No consequence.

Simultaneous faults A and C

Isc < Isc maximum (resistance of earth electrodes).

Both polarities (positive and negative) of the source are concerned.

Simultaneous faults A and D

Isc < Isc maximum (resistance of earth electrodes).

Each polarity may be concerned at voltage U.

Worst case

Simultaneous faults A and D

Each polarity may be concerned at voltage U.

Distribution system no. 2: earthed middle point

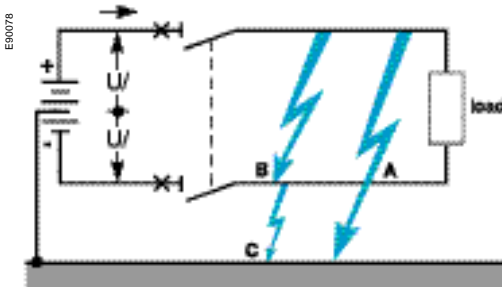

The middle point of the source is earthed

Fault B

Isc maximum at U.

Both polarities (positive and negative) of the source are concerned by the fault.

Fault A or C

Isc < Isc maximum at U/2.

The negative or positive polarity of the source is concerned.

Simultaneous faults A and C

Isc < Isc maximum (resistance of earth electrodes) at U.

Both polarities (positive and negative) of the source are concerned.

Worst case

Fault A or C

Each polarity may be concerned at voltage U/2.

Distribution system no. 3: earthed negative polarity

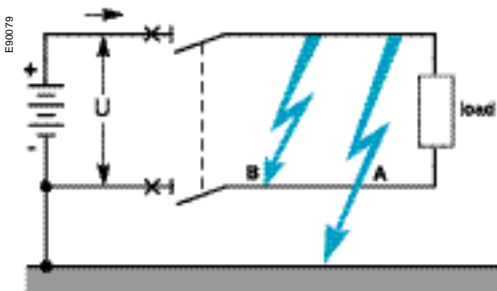

The negative polarity of the source is earthed

Fault A

Isc < Isc maximum (resistance of earth electrodes).

The positive polarity of the source is concerned.

Fault B

Isc maximum.

Both polarities (positive and negative) of the source are concerned.

Worst case

Fault A

Isc maximum on one polarity.

All poles taking part in breaking must be placed in series on the positive polarity.

If for any reason the negative polarity of the source must be earthed, provide an additional pole that will be used for isolation of the negative pole but not for breaking.

Types of DC distribution systems (cont.) Pole arrangements

The way the poles are arranged depends on the type of distribution system and the operational voltage.

The Masterpact NW DC range offers 3 pole-connection versions: C, D and E. The series connections required for the selected version are supplied with the circuit breaker. All Masterpact NW DC circuit breakers therefore come **ready for connection**.

Selection table

Type of circuit breaker	NW10-20-40 NDC	NW10-20-40 HDC	
Rated operational voltage (V DC)	500	500	900
Breaking capacity (L/R ≤ 15 ms)	35 kA	85 kA	35 kA
Distribution system no. 1: Isolated	Version C	Version E	Version E
Distribution system no. 2: Earthed middle point	Version C	Version C	Version C
Distribution system no. 3: Earthed negative polarity	Version C	Version D	Version D

Version C
Breaking capacity N & H

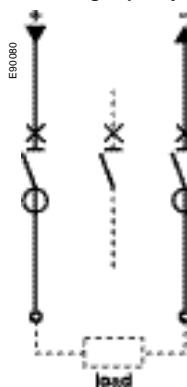

Version D
Breaking capacity H

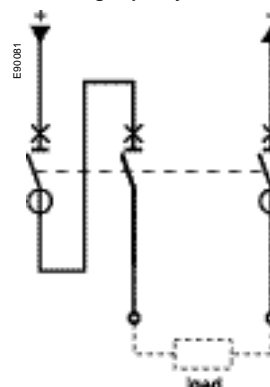

Version E
Breaking capacity H

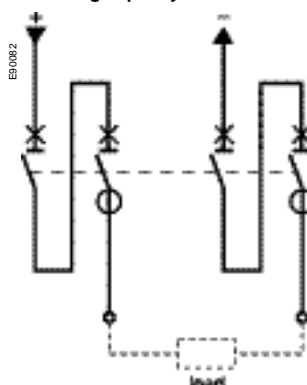

Note: The diagrams are represented for circuit breakers viewed from the front.

Circuit breakers and switch-disconnectors NW10 to NW40

EB8193_A



Common characteristics		Versions C, D	Version E
Number of poles		3	4
Rated insulation voltage (V)	Ui	1000	1000
Impulse withstand voltage (kV)	Uimp	12	12
Rated operational voltage (V DC)	Ue	500/900	500/900
Suitability for isolation	IEC 60947-2		
Degree of pollution	IEC60664-1	4	4
Utilisation category	IEC60947-2	B	B

Circuit-breaker characteristics as per IEC 60947-2				NW10		NW20		NW40		
Rated current (A)	I_n at 40 °C / 50 °C (*)			1000		2000		4000		
Type of circuit breaker				N	H	N	H	N	H	
Ultimate breaking capacity (kA)	L/R ≤ 5 ms	I_{cu}	500 V DC	85	100	85	100	85	100	
			750 V DC	-	85	-	85	-	85	
			900 V DC	-	85	-	85	-	85	
	L/R ≤ 15 ms		500 V DC	35	85	35	85	35	85	
			750 V DC	-	50	-	50	-	50	
			900 V DC	-	35	-	35	-	35	
	L/R ≤ 30 ms		500 V DC	25	50	25	50	25	50	
			750 V DC	-	50	-	50	-	50	
			900 V DC	-	25	-	25	-	25	
Rated service breaking capacity (kA)	I_{cs}	% I _{cu}	100 %		100 %		100 %			
Rated short-time withstand current (kA) - V DC	I_{cw}	1 s	50	85	50	85	50	85		
Rated making capacity (kA)	I_{cm}	% I _{cu}	100 %		100 %		100 %			
Break time (ms)				30 to 75		30 to 75		30 to 75		
Closing time (ms)				< 70		< 70		< 70		
Circuit-breaker characteristics as per IEC 60947-3					HA		HA		HA	
Type of switch-disconnector					HA		HA		HA	
Rated making capacity (kA)	I_{cm}			-	85	-	85	-	85	
Rated short-time withstand current (kA) - V DC	I_{cw}	1 s		-	85	-	85	-	85	
Installation, connection and maintenance										
Service life C/O cycles x 1000	mechanical	with maintenance		20	20	20	20	20	20	
		without maintenance		10	10	10	10	10	10	
	electrical	without maintenance		500 V DC	8.5	8.5	5	5	2	2
			900 V DC	-	2	-	2	-	1	
Connection	drawout	rear	horizontal	■	■	■	■	-	-	
			vertical	■	■	■	■	■	■	
	fixed	rear	horizontal	■	■	■	■	-	-	
			vertical	■	■	■	■	■	■	
Dimensions (mm) H x W x D with series connections	drawout	3P			439 x 441 x 494				439 x 441 x 594	
		4P			439 x 556 x 494				439 x 556 x 594	
	fixed	3P			352 x 422 x 427				352 x 422 x 527	
		4P			352 x 537 x 427				352 x 537 x 527	
Weight (kg) with series connections (approximate)	drawout	3P			90 to 116 kg					
		4P			125 to 146 kg					
	fixed	3P			60 to 86 kg					
		4P			85 to 106 kg					

(*) 50 °C: refer to temperature derating table for NW40.

All Masterpact NW DC circuit breakers are equipped with Micrologic control units that are interchangeable on site.

Micrologic DC 1.0

Type of protection

1 = instantaneous

Control unit version

Identification of the different control unit generations (0 for the first generation)

Micrologic DC 1.0

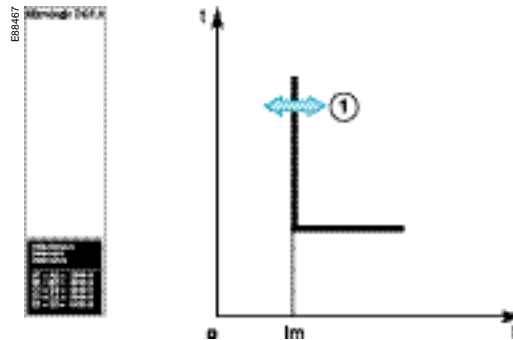

- this control unit is designed to protect power circuits and load devices
- it is associated with sensors with instantaneous thresholds that can be adjusted on site.

3 sensor versions provide different threshold ranges:

- 1250 to 2500 A
- 2500 to 5400 A
- 5000 to 11000 A

- no overload protection (thermal relay type) is provided on the DC range.

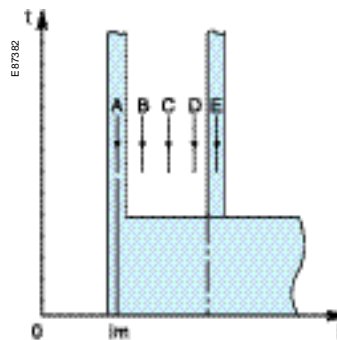

Settings are accessible in front, behind the door of the cubicle. Both sensors must have the same settings.

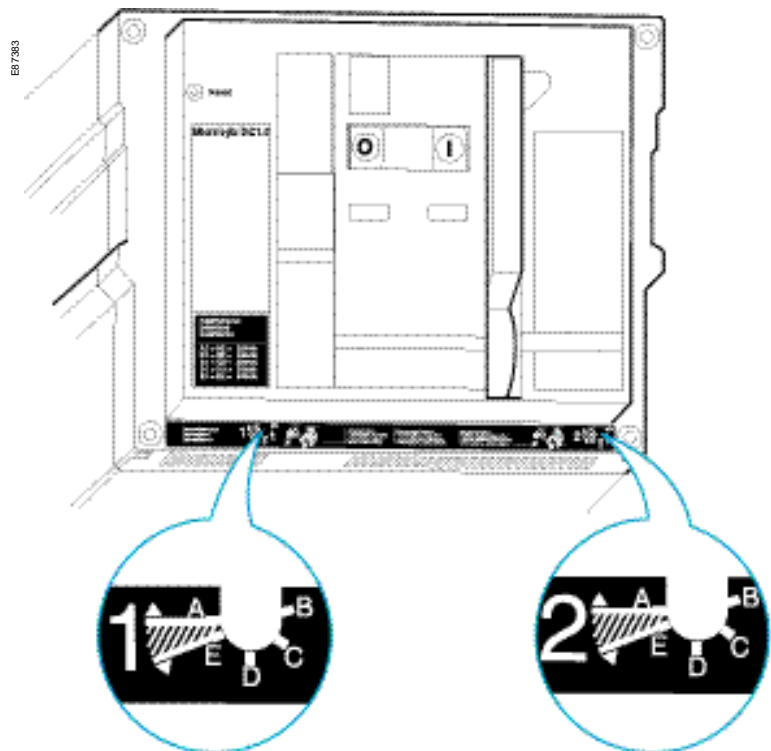

instantaneous
instantané
Instantáneo
A1 = A2 = 2500A
B1 = B2 = 3300A
C1 = C2 = 4000A
D1 = D2 = 5000A
E1 = E2 = 5400A

IM thresholds

Settings indicated on dials: A, B, C, D or E.

Sensor versions	Minimum				Maximum Settings E1 and E2
	Settings A1 and A2	Settings B1 and B2	Settings C1 and C2	Settings D1 and D2	
1250/2500	1250 A	1500 A	1600 A	2000 A	2500 A
2500/5400	2500 A	3300 A	4000 A	5000 A	5400 A
5000/11000	5000 A	8000 A	10000 A	11000 A	11000 A
Tolerances	±8 %	±10 %	±10 %	±10 %	±10 %

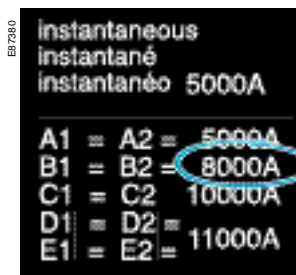

E.g. Trip threshold set to 8000 A.

Intermediate values can also be set.

Eleven other settings are available (not indicated on the adjustment knobs).

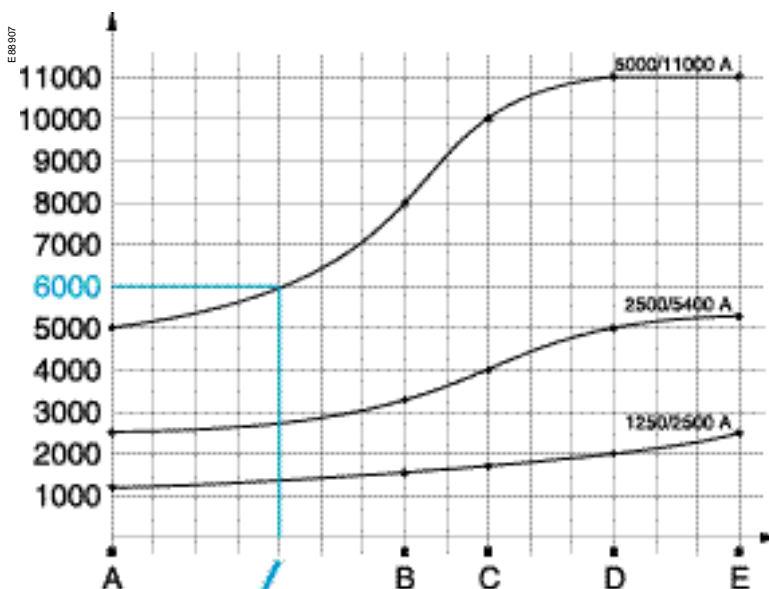

E.g. Trip threshold set to 6000 A.

The COM option is required for integration of the circuit breaker or switch-disconnector in a supervision system.

Masterpact uses the Digipact or Modbus communications protocol for full compatibility with the SMS PowerLogic power-monitoring system. An external gateway is available for communication on other networks:

- Profibus
- Ethernet...

Eco COM is limited to the transmission of metering data and does not allow the control of the circuit breaker.

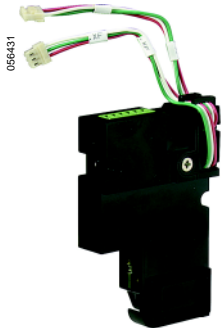

Digipact "device" communication module.



Digipact "chassis" communication module.

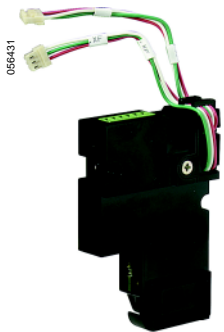

Modbus "device" communication module.



Modbus "chassis" communication module.

For fixed devices, the COM option is made up of:

- a "device" communication module, installed behind the Micrologic control unit and supplied with its set of sensors (OF, SDE, PF and CH micro-contacts) and its kit for connection to XF and MX communicating voltage releases.

For drawout devices, the COM option is made up of:

- a "device" communication module, installed behind the Micrologic control unit and supplied with its set of sensors (OF, SDE, PF and CH micro-contacts) and its kit for connection to XF and MX communicating voltage releases
- a "chassis" communication module supplied separately with its set of sensors (CE, CD and CT contacts).

Status indication by the COM option is independent of the device indication contacts. These contacts remain available for conventional uses.

Digipact or Modbus "device" communication module

This module is independent of the control unit. It receives and transmits information on the communication network. An infra-red link transmits data between the control unit and the communication module.

Consumption: 30 mA, 24 V.

Digipact or Modbus "chassis" communication module

This module is independent of the control unit. The Modbus "chassis" communication module makes it possible to address the chassis and to conserve the address when the circuit breaker is in the disconnected position.

Consumption: 30 mA, 24 V.

XF and MX communicating voltage releases

The XF and MX communicating voltage releases are equipped for connection to the "device" communication module.

Remote-tripping functions (second MX or MN) are independent of the communication option. These releases are therefore not equipped for connection to the "device" communication module.

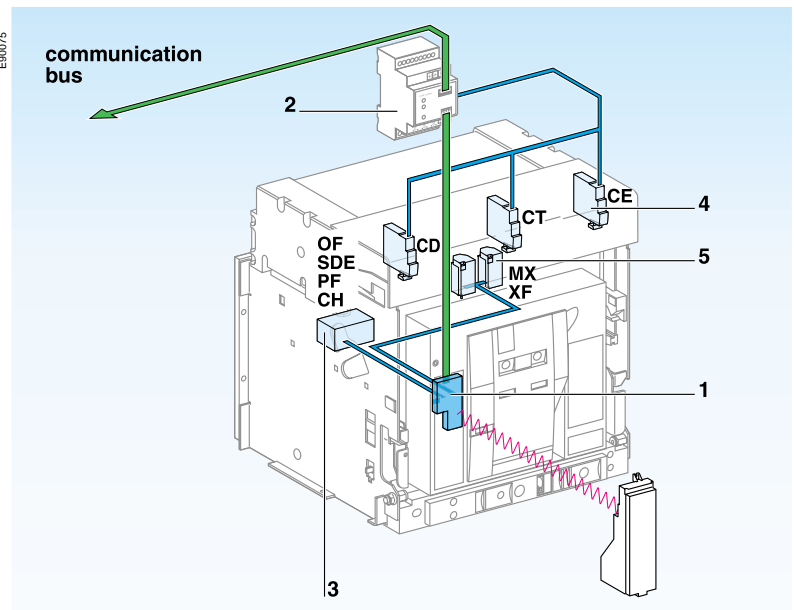

- | | |
|---------------------------------------|-----------------------|
| 1 "device" communication module | — : hard wiring |
| 2 "chassis" communication module | — : communication bus |
| 3 OF, SDE, PF and CH "device" sensors | |
| 4 CE, CD and CT "chassis" sensors | |
| 5 MX and XF release | |

Masterpact circuit breakers and switch-disconnectors are compatible with the Digipact or Modbus COM option.

The COM option may be used to:

- identify the device
- indicate status conditions
- control the device.

	Switch-disconnector and circuit breaker with communication bus	
	Digipact	Modbus
Device identification		
Address	■	■
Rating	-	-
Type of device	-	-
Type of control unit	-	-
Status indications		
ON/OFF (OF)	■	■
Spring charged (CH)	■	■
Ready to close (PF)	■	■
Fault-trip (SDE)	-	-
Connected/disconnected/test position (CE/CD/CT)	■	■
Controls		
ON/OFF (MX/XF)	■	■
Spring charging	-	-
Reset of the mechanical indicator	-	-

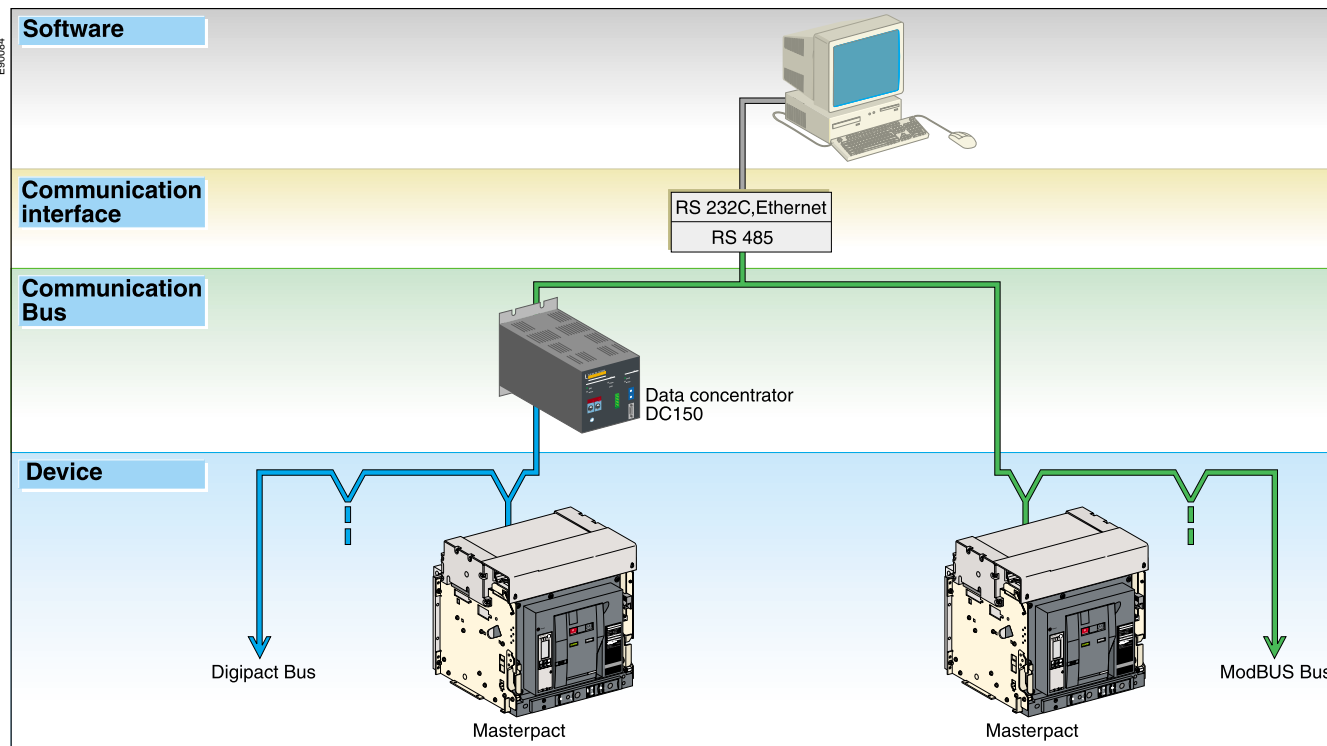

Devices

Circuit breakers equipped with Micrologic control units may be connected to either a Digipact or Modbus communication bus.

Communication bus

Digipact

The Digipact bus is the internal bus of the low-voltage switchboard in which the Digipact communicating devices are installed (Masterpact with Digipact COM, PM150, SC150, UA150, etc.). This bus must be equipped with a DC150 data concentrator (see the Powerlogic System catalogue).

Addresses

Addressing is carried out by the DC150 data concentrator.

Number of devices

The maximum number of devices that may be connected to the Digipact bus is calculated in terms of "communication points". These points correspond to the amount of traffic the bus can handle. The total number of points for the various devices connected to a single bus must not exceed 100. If the required devices represent more than 100 points, add a second Digipact internal bus.

Communicating device	Number of points
DC150	4
Micrologic + COM Digipact	4
PM150	4
SC150	4
UA150	4

Length of bus

The maximum recommended length for the Digipact internal bus is 200 meters.

Bus power source

Power is supplied by the DC150 data concentrator (24 V).

Modbus bus

The Modbus RS485 (JBus) system is an open bus on which communicating Modbus devices (Masterpact with Modbus COM, PM300, Sepam, VigiloHM, etc.) are installed. All types of PLCs and microcomputers may be connected to the bus.

Addresses

The software layer of the Modbus protocol can manage up to 255 addresses (1 to 255).

The "device" communication module comprises three addresses linked to:

- circuit-breaker manager
- measurement manager
- protection manager.

The "chassis" communication module comprises one address linked to:

- the chassis manager.

The division of the system into four managers secures data exchange with the supervision system and the circuit-breaker actuators.

The manager addresses are automatically derived from the circuit-breaker address @xx entered via the Micrologic control unit (the default address is 47).

Logic addresses

@xx	Circuit-breaker manager	(1 to 47)
@xx + 50	Chassis manager	(51 to 97)
@xx + 200	Measurement manager	(201 to 247)
@xx + 100	Protection manager	(101 to 147)

Number of devices

The maximum number of devices that may be connected to the Modbus bus depends on the type of device (Masterpact with Modbus COM, PM300, Sepam, VigiloHM, etc.), the baud rate (19200 is recommended), the volume of data exchanged and the desired response time. The RS485 physical layer offers up to 32 connection points on the bus (1 master, 31 slaves).

A fixed device requires only one connection point (communication module on the device).

A drawout device uses two connection points (communication modules on the device and on the chassis).

The number must never exceed 31 fixed devices or 15 drawout devices.

Length of bus

The maximum recommended length for the Modbus bus is 1200 meters.

Bus power source

A 24 V DC power supply is required (less than 20% ripple, insulation class II).

Communication interface

The Modbus bus may be connected to the central processing device in any of three manners:

- direct link to a PLC. The communication interface is not required if the PLC is equipped with a Modbus port
- direct link to a computer. The Modbus (RS485) / Serial port (RS232C) communication interface is required
- connection to a TCP/IP (Ethernet) network. The Modbus (RS485) / TCP/IP (Ethernet) communication interface is required.

Software

To make use of the information provided by the communicating devices, software with a Modbus driver must be used.

Micrologic utilities

This is a set of Modbus drivers that may be used with a PC to:

- display the variables (I, U, P, E, etc.) with the RDU (Remote Display Utility)
 - read/write the settings with the RSU (Remote Setting Utility)
 - remotely control (ON / OFF) the device with the RCU (Remote Control Utility).
- These utilities are available upon request.

SMS (System Manager Software)

SMS is power management software for the control and monitoring of LV and MV electrical installations.

The SMS family includes a number of products for all types of applications. SMS can communicate with all intelligent devices of the electrical installation including:

- Power Meter and Circuit Monitor products
- LV circuit breakers and switchdisconnectors
- Sepam units.

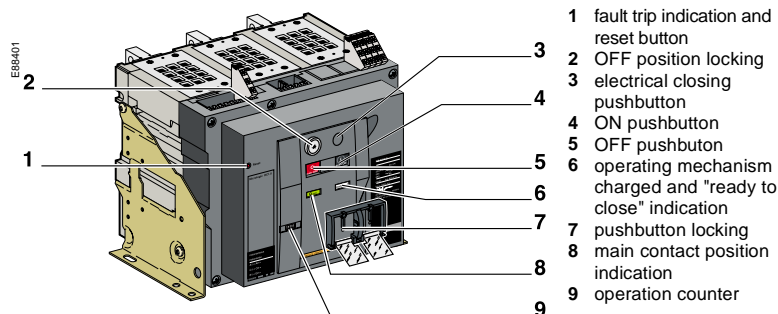

Access to pushbuttons protected by transparent cover.



Pushbutton locking using a padlock.



OFF position locking using a padlock.



OFF position locking using a keylock.

Pushbutton locking

■ The transparent cover blocks access to the pushbuttons used to open and close the device.

It is possible to independently lock the opening button and the closing button. The locking device is often combined with a remote operating mechanism.

The pushbuttons may be locked using either:

- three padlocks (not supplied)
- lead seal
- two screws.

Device locking in the OFF position

The circuit breaker is locked in the OFF position by physically maintaining the opening pushbutton pressed down:

- using padlocks (one to three padlocks, not supplied)
- using keylocks (one or two different keylocks, supplied).

Keys may be removed only when locking is effective (Profalux or Ronis type locks).

The keylocks are available in any of the following configurations:

- one keylock
- one keylock mounted on the device + one identical keylock supplied separately for interlocking with another device
- two different key locks for double locking.

Profalux and Ronis keylocks are compatible with each other.

A locking kit (without locks) is available for installation of one or two keylocks (Ronis, Profalux, Kirk or Castell).

Accessory-compatibility

3 padlocks and/or 2 keylocks

Cable-type door interlock

This option prevents door opening when the circuit breaker is closed and prevents circuit breaker closing when the door is open.

For this, a special plate associated with a lock and a cable is mounted on the right side of the circuit breaker.

With this interlock installed, the source changeover function cannot be implemented.

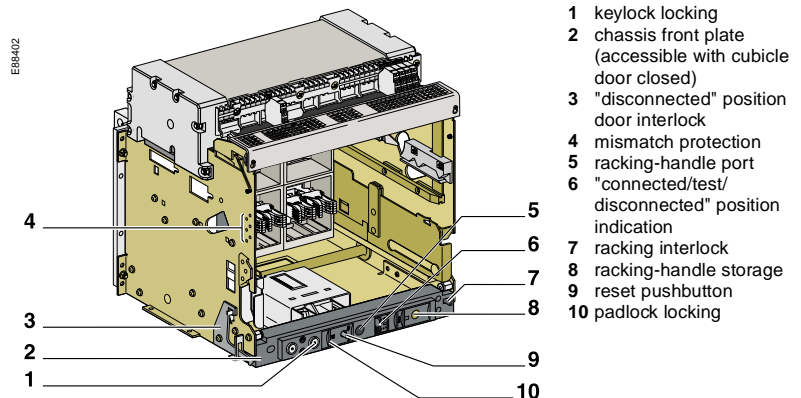

"Disconnected" position locking

Mounted on the chassis and accessible with the door closed, these devices lock the circuit breaker in the "disconnected" position in two manners:

- using padlocks (standard), up to three padlocks (not supplied)
- using keylocks (optional), one or two different keylocks are available.

Profalux and Ronis keylocks are available in different options:

- one keylock
- two different keylocks for double locking
- one (or two) keylocks mounted on the chassis + one (or two) identical keylocks supplied separately for interlocking with another device.

A locking kit (without locks) is available for installation of one or two keylocks (Ronis, Profalux, Kirk or Castell).

"Connected", "disconnected" and "test" position locking

The "connected", "disconnected" and "test" positions are shown by an indicator. The exact position is obtained when the racking handle blocks. A release button is used to free it.

On request, the "disconnected" position locking system may be modified to lock the circuit breaker in any of the three positions, "connected", "disconnected" and "test".

Door interlock catch

Mounted on the right or left-hand side of the chassis, this device inhibits opening of the cubicle door when the circuit breaker is in "connected" or "test" position. If the breaker is put in the "connected" position with the door open, the door may be closed without having to disconnect the circuit breaker.

Racking interlock

This device prevents insertion of the racking handle when the cubicle door is open.

Cable-type door interlock

This option is identical for fixed and drawout versions.

Racking interlock between crank and OFF pushbutton

This option makes it necessary to press the OFF pushbutton in order to insert the racking handle and holds the device open until the handle is removed.

Automatic spring discharge before breaker removal

This option discharges the springs before the breaker is removed from the chassis.

Mismatch protection

Mismatch protection ensures that a circuit breaker is installed only in a chassis with compatible characteristics. It is made up of two parts (one on the chassis and one on the circuit breaker) offering twenty different combinations that the user may select.



Racking interlock.



Mismatch protection.

Indication contacts are available:

- in the standard version for relay applications
- in a low-level version for control of PLCs and electronic circuits.



ON/OFF indication contacts (OF) (microswitch type).

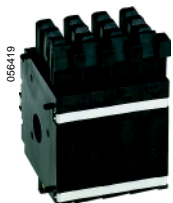

ON/OFF indication contacts (OF) (rotary type).

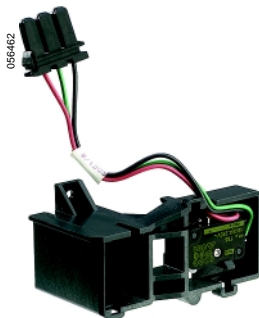

Additional "fault-trip" indication contacts (SDE).



Combined contacts.

ON/OFF indication contacts (OF)

Rotary type changeover contacts directly driven by the mechanism. These contacts trip when the minimum isolation distance between the main circuit-breaker contacts is reached.

OF			
Supplied as standard			4
Maximum number			12
Breaking capacity (A)	standard		minimum load: 100 mA/24 V
p.f.: 0.3		V AC	240/380
AC12/DC12			10/6*
			480
			10/6*
			690
			6
		V DC	24/48
			10/6*
			125
			10/6*
			250
			3
	low-level		minimum load: 2 mA/15 V DC
		V AC	24/48
			6
			240
			6
			380
			3
		V DC	24/48
			6
			125
			6
			250
			3

* standard contacts: 10 A; optional contacts: 6 A.

"Fault-trip" indication contacts (SDE)

Circuit-breaker tripping due to a fault is signalled by:

- a red mechanical fault indicator (reset)
- one changeover contact (SDE).

Following tripping, the mechanical indicator must be reset before the circuit breaker may be closed.

SDE			
Supplied as standard			1
Maximum number			2
Breaking capacity (A)	standard		minimum load: 100 mA/24 V
p.f.: 0.3		V AC	240/380
AC12/DC12			5
			480
			5
			690
			3
		V DC	24/48
			3
			125
			0.3
			250
			0.15
	low-level		minimum load: 2 mA/15 V DC
		V AC	24/48
			3
			240
			3
			380
			3
		V DC	24/48
			3
			125
			0.3
			250
			0.15

Combined "connected/closed" contacts (EF)

The contact combines the "device connected" and the "device closed" information to produce the "circuit closed" information.

Supplied as an option for Masterpact NW, it is mounted in place of the connector of an additional OF contact.

EF			
Maximum number			8
Breaking capacity (A)	standard		minimum load: 100 mA/24 V
p.f.: 0.3		V AC	240/380
AC12/DC12			6
			480
			6
			690
			6
		V DC	24/48
			2.5
			125
			0.8
			250
			0.3
	low-level		minimum load: 2 mA/15 V DC
		V AC	24/48
			5
			240
			5
			380
			5
		V DC	24/48
			2.5
			125
			0.8
			250
			0.3

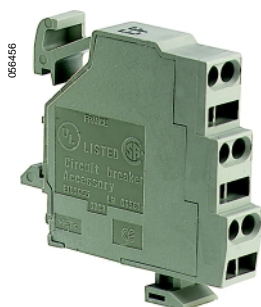

CE, CD and CT "connected/disconnected/test" position carriage switches.

"Connected", "disconnected" and "test" position carriage switches

Three series of optional auxiliary contacts are available for the chassis:

- changeover contacts to indicate the "connected" position (CE)
- changeover contacts to indicate the "disconnected" position (CD). This position is indicated when the required clearance for isolation of the power and auxiliary circuits is reached.
- changeover contacts to indicate the "test" position (CT). In this position, the power circuits are disconnected and the auxiliary circuits are connected.

Additional actuators

A set of additional actuators may be installed on the chassis to change the functions of the carriage switches.

Contacts		CE	CD	CT	
Maximum number	standard	3	3	3	
	with additional actuators	9	0	0	
		6	3	0	
		6	0	3	
Breaking capacity (A) p.f.: 0.3 AC12/DC12	standard	minimum load: 100 mA/24 V			
		V AC	240	8	
			380	8	
			480	8	
	690		6		
	V DC	24/48	2.5		
		125	0.8		
		250	0.3		
		low-level			minimum load: 2 mA/15 V DC
	V AC	24/48	5		
		240	5		
		380	5		
V DC		24/48	2.5		
	125	0.8			
	250	0.3			

Two solutions are available for remote operation of Masterpact devices:

- a point-to-point solution
- a bus solution with the COM communication option.



Note:

An opening order always takes priority over a closing order.

Note: If opening and closing orders occur simultaneously, the mechanism discharges without any movement of the main contacts. The circuit breaker remains in the open position (OFF).

In the event of maintained opening and closing orders, the standard mechanism provides an anti-pumping function by blocking the main contacts in open position.

Anti-pumping function. After fault tripping or intentional opening using the manual or electrical controls, the closing order must first be discontinued, then reactivated to close the circuit breaker.

When the automatic reset after fault trip (RAR) option is installed, to avoid pumping following a fault trip, the automatic control system must take into account the information supplied by the circuit breaker before issuing a new closing order or blocking the circuit breaker in the open position (information on the type of fault, e.g. overload, short-time fault, earth fault, earth leakage, short-circuit, etc.).

The remote ON / OFF function is used to remotely open and close the circuit breaker. It is made up of:

- an electric motor (MCH) equipped with a "springs charged" limit switch contact (CH)
- two voltage releases:
 - a closing release (XF)
 - an opening release (MX).

Optionally, other functions may be added:

- a "ready to close" contact (PF)
- an electrical closing pushbutton (BPFE)
- remote reset following a fault.

A remote-operation function is generally combined with:

- device ON / OFF indication (OF)
- "fault-trip" indication (SDE).

Wiring diagram of a point-to-point remote ON / OFF function

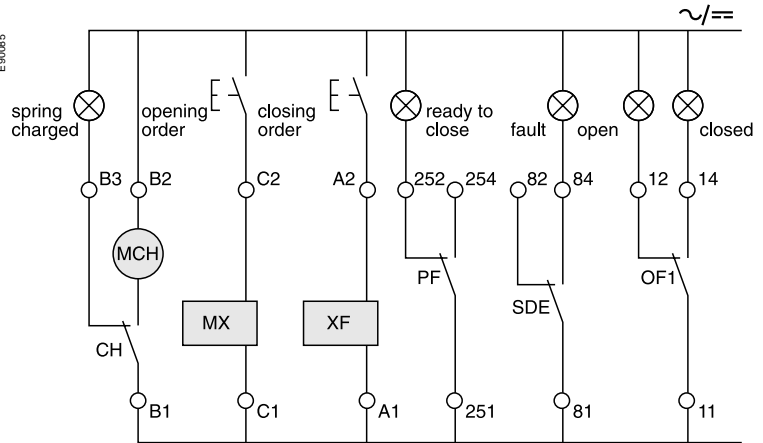

Wiring diagram of a bus-type remote ON / OFF function

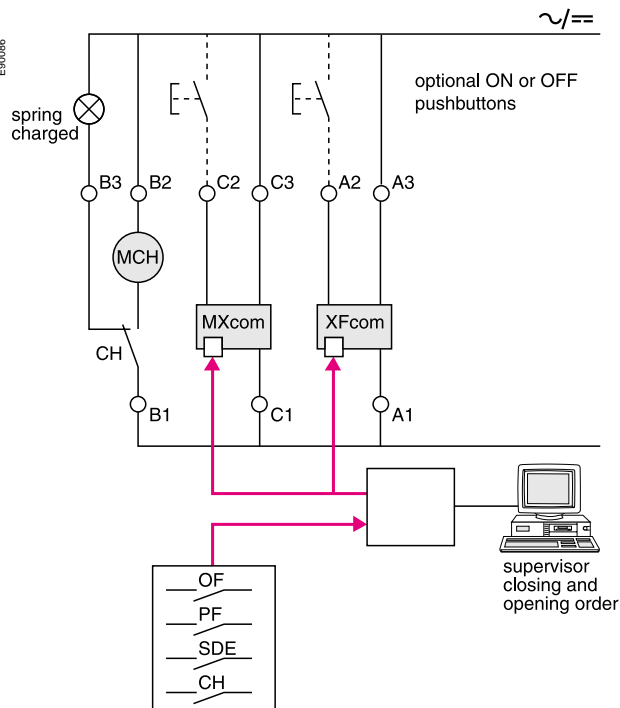

Note:

MX communicating releases are of the impulse type only and cannot be used to lock a circuit breaker in OFF position. For locking in OFF position, use the remote tripping function (2nd MX or MN).



Electric motor (MCH).

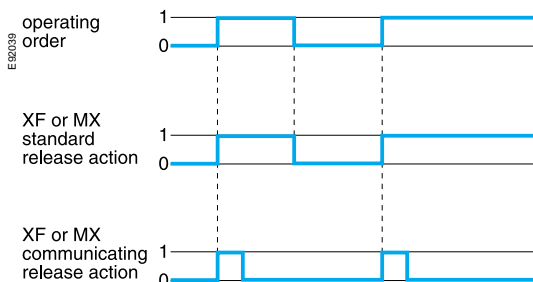

XF and MX voltage releases.



"Ready to close" contacts (PF).

Electric motor (MCH)

The electric motor automatically charges and recharges the spring mechanism when the circuit breaker is closed. Instantaneous reclosing of the breaker is thus possible following opening. The spring-mechanism charging handle is used only as a backup if auxiliary power is absent.

The electric motor (MCH) is equipped as standard with a limit switch (CH) that signals the "charged" position of the mechanism (springs charged).

Characteristics

Power supply	V AC 50/60 Hz	48/60 - 100/130 - 200/240 - 277 - 380/415 - 400/440 - 480
	V DC	24/30 - 48/60 - 100/125 - 200/250
Operating threshold	0.85 to 1.1 Un	
Consumption (VA or W)	180	
Motor overcurrent	2 to 3 In for 0.1 s	
Charging time	maximum 4 seconds	
Operating frequency	maximum 3 cycles per minute	
CH contact	10 A at 240 V	

Voltage releases (XF and MX)

Their supply can be maintained or automatically disconnected.

Closing release (XF)

The XF release remotely closes the circuit breaker if the spring mechanism is charged.

Opening release (MX)

The MX release instantaneously opens the circuit breaker when energised. It locks the circuit breaker in OFF position if the order is maintained (except for MX "communicating" releases).

Note: Whether the operating order is maintained or automatically disconnected (pulse-type), XF or MX "communicating" releases ("bus" solution with "COM" communication option) always have an impulse-type action.

Characteristics

Characteristics	XF	MX
Power supply	V AC 50/60 Hz	24 - 48 - 100/130 - 200/250 - 277 - 380/480
	V DC	12 - 24/30 - 48/60 - 100/130 - 200/250
Operating threshold	0.85 to 1.1 Un	0.7 to 1.1 Un
Consumption (VA or W)	pick-up: 200 (during 200 ms)	pick-up: 200 (during 200 ms)
	hold: 4.5	hold: 4.5
Circuit-breaker response time at Un	70 ms ± 10 (NW ≤ 4000 A)	50 ms ± 10 (NW)
	80 ms ± 10 (NW > 4000 A)	

"Ready to close" contact (PF)

The "ready to close" position of the circuit breaker is indicated by a mechanical indicator and a PF changeover contact. This signal indicates that all the following are valid:

- the circuit breaker is in the OFF position
- the spring mechanism is charged
- a maintained opening order is not present:
 - MX energised
 - fault trip
 - remote tripping (second MX or MN)
 - device not completely racked in
 - device locked in OFF position
 - device interlocked with a second device.

Characteristics

Supplied as standard	-	
Maximum number	1	
Breaking capacity p.f.: 0.3 AC12/DC12	standard	minimum load: 100 mA/24 V
	V AC	240/380
	480	5
	690	3
	V DC	24/48
	125	0,3
	250	0,15
	low-level	minimum load: 2 mA/15 V DC
	V AC	24/48
	240	3
	380	3
	V DC	24/48
	125	0,3
	250	0,15

Electrical closing pushbutton (BPFE)

Located on the front panel, this pushbutton carries out electrical closing of the circuit breaker. It is generally associated with the transparent cover that protects access to the closing pushbutton.

Electrical closing via the BPFE pushbutton takes into account all the safety functions that are part of the control/monitoring system of the installation.

The BPFE connects to the closing release (XF) in place of the COM module.

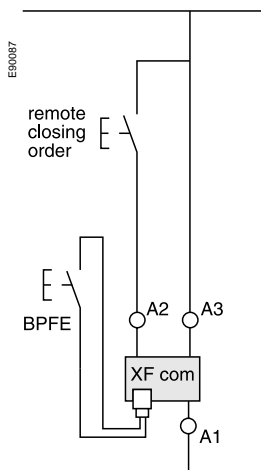

Remote reset after fault trip

Electrical reset after fault trip (Res)

Following tripping, this function resets the “fault trip” indication contacts (SDE) and the mechanical indicator and enables circuit breaker closing.

Power supply: 110 / 130 V AC and 200 / 240 V AC.

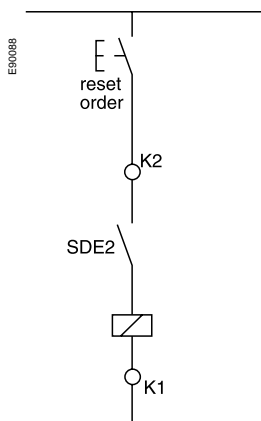

Automatic reset after fault trip (RAR)

Following tripping, a reset of the mechanical indicator (reset button) is no longer required to enable circuit-breaker closing. The mechanical (reset button) and electrical (SDE) indications remain in fault position until the reset button is pressed.

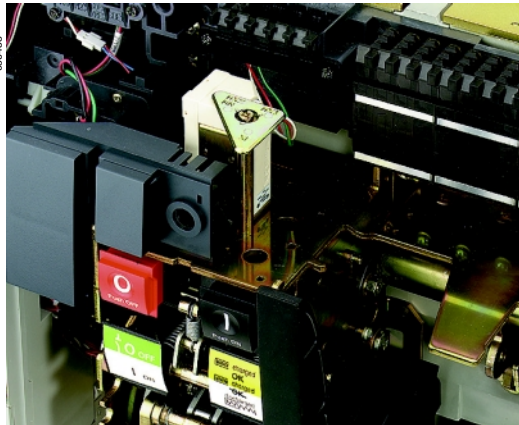

MX or MN voltage release.

This function opens the circuit breaker via an electrical order. It is made up of:

- a shunt release (second MX)
- or an undervoltage release (MN)
- or a delayed undervoltage release (MN + delay unit).

These releases (2nd MX or MN) cannot be operated by the communication bus. The delay unit, installed outside the circuit breaker, may be disabled by an emergency OFF button to obtain instantaneous opening of the circuit breaker.

Wiring diagram for the remote-tripping function

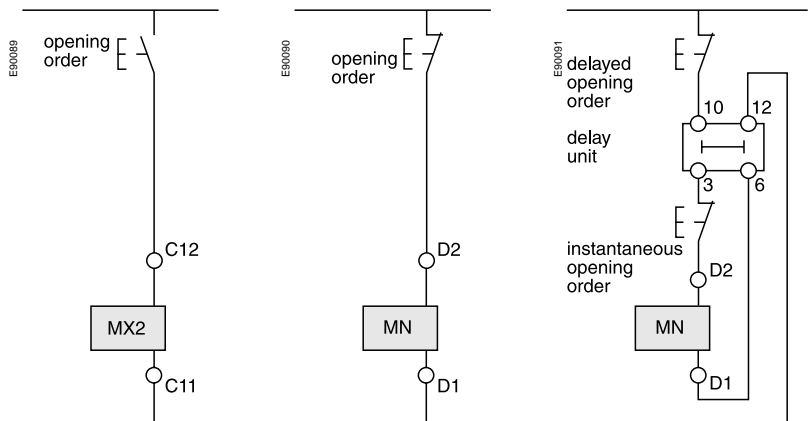

Voltage releases (second MX)

When energised, the MX voltage release instantaneously opens the circuit breaker. A continuous supply of power to the second MX locks the circuit breaker in the OFF position.

Characteristics

Power supply	V AC 50/60 Hz	24 - 48 - 100/130 - 200/250 - 277 - 380/480
	V DC	24/30 - 48/60 - 100/130 - 200/250
Operating threshold	0.7 to 1.1 Un	
Permanent locking function	0.85 to 1.1 Un	
Consumption (VA or W)	pick-up: 200 (during 200 ms)	hold: 4.5
Circuit-breaker response time at Un	50 ms ±10	

Instantaneous voltage releases (MN)

The MN release instantaneously opens the circuit breaker when its supply voltage drops to a value between 35% and 70% of its rated voltage. If there is no supply on the release, it is impossible to close the circuit breaker, either manually or electrically. Any attempt to close the circuit breaker has no effect on the main contacts. Circuit-breaker closing is enabled again when the supply voltage of the release returns to 85% of its rated value.

Characteristics

Power supply	V AC 50/60 Hz	24 - 48 - 100/130 - 200/250 - 380/480
	V DC	12 - 24/30 - 48/60 - 100/130 - 200/250
Operating threshold	opening	0.35 to 0.7 Un
	closing	0.85 Un
Consumption (VA or W)	pick-up: 200 (during 200 ms)	hold: 4.5
MN consumption with delay unit	pick-up: 400 (during 200 ms)	hold: 4.5
Circuit-breaker response time at Un	90 ms ±5	

MN delay units

To eliminate circuit-breaker nuisance tripping during short voltage dips, operation of the MN release can be delayed. This function is achieved by adding an external delay unit in the MN voltage-release circuit. Two versions are available, adjustable and non-adjustable.

Characteristics

Power supply	non-adjustable	100/130 - 200/250
	adjustable	48/60 - 100/130 - 200/250 - 380/480
Operating threshold	opening	0.35 to 0.7 Un
	closing	0.85 Un
Consumption of delay unit alone (VA or W)	pick-up: 200 (during 200 ms)	hold: 4.5
Circuit-breaker response time at Un	non-adjustable	0.25 s
	adjustable	0.5 s - 0.9 s - 1.5 s - 3 s

056463



Auxiliary terminal shield (CB)

Optional equipment mounted on the chassis, the shield prevents access to the terminal block of the electrical auxiliaries.

056464

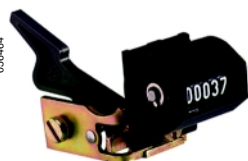

Operation counter (CDM)

The operation counter sums the number of operating cycles and is visible on the front panel. It is compatible with manual and electrical control functions.

E-47535

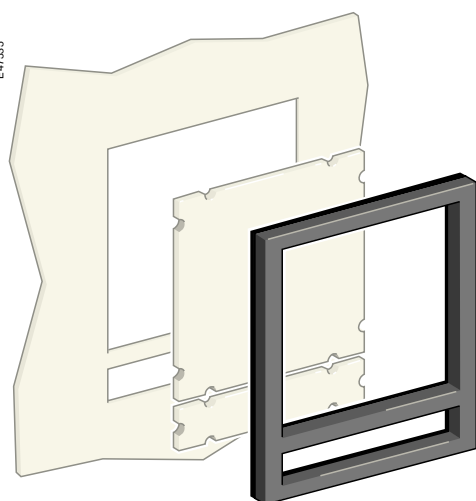

Escutcheon (CDP)

Optional equipment mounted on the door of the cubicle, the escutcheon increases the degree of protection to IP 40 (circuit breaker installed free standing: IP30) . It is available in fixed and drawout versions.

Blanking plate (OP) for escutcheon

Used with the escutcheon, this option closes off the door cut-out of a cubicle not yet equipped with a device. It may be used with the escutcheon for both fixed and drawout devices.

Transparent cover (CP) for escutcheon

Optional equipment mounted on the escutcheon, the cover is hinged and secured by a screw. It increases the degree of protection to IP 54, IK10. It adapts to both fixed and drawout devices.

Escutcheon (CDP) with blanking plate.

016819

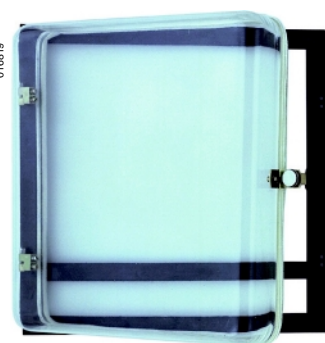

Transparent cover (CP) for escutcheon.

Presentation	2
Functions and characteristics	5
NW10 to 40 DC circuit breakers	26
Fixed device	26
Drawout device	30
Accessories	34
Electrical diagrams	37
Installation recommendations	43
Additional characteristics	55
Catalogue numbers	59

Dimensions

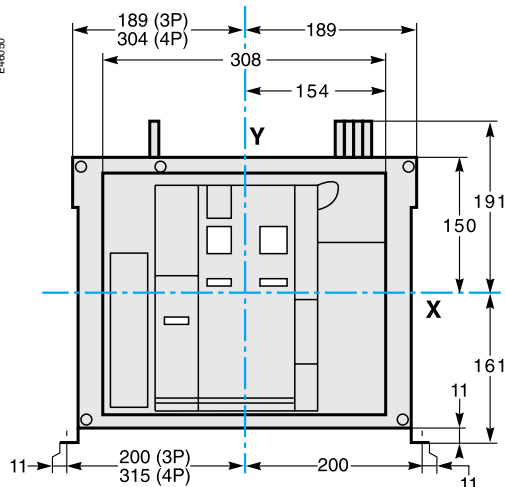
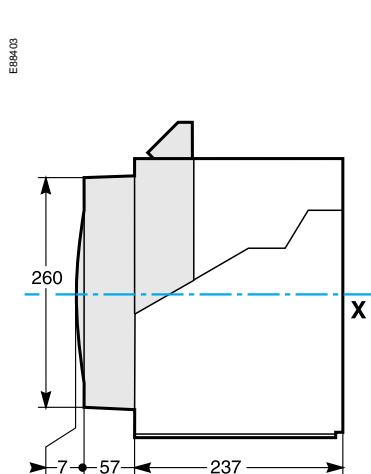

Mounting on base plate or rails

Mounting detail

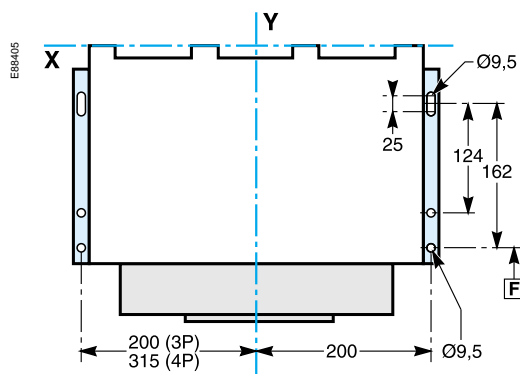
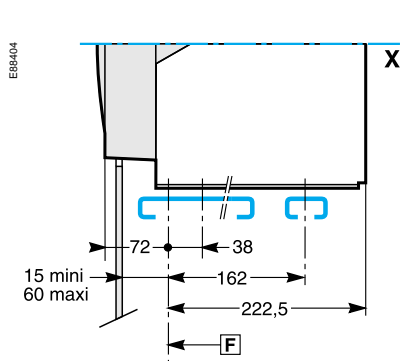

Safety clearances

Door cutout

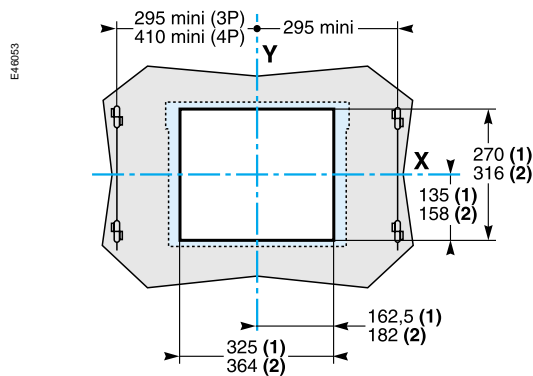
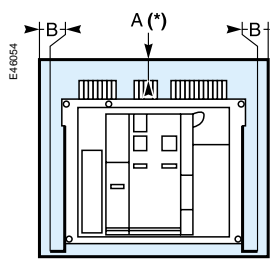
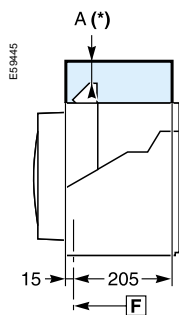

	Insulated parts	Metal parts	Energised parts
A	0	0	100
B	0	0	60

Note:

(1) Without escutcheon
(2) With escutcheon

X and Y are the symmetry planes for a 3-pole device.

A(*) An overhead clearance of 110 mm is required to remove the arc chutes.

An overhead clearance of 20 mm is required to remove the terminal block.

[F]: Datum.

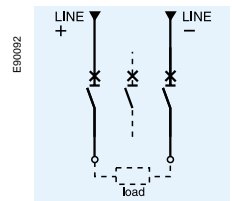

Connections

Horizontal rear connection (NW10 - NW20)

Detail

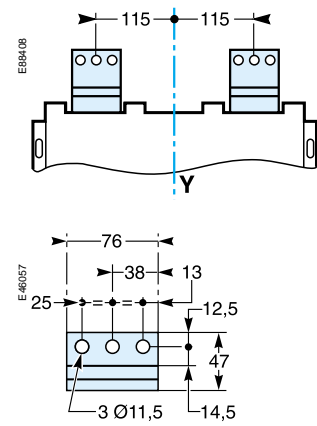
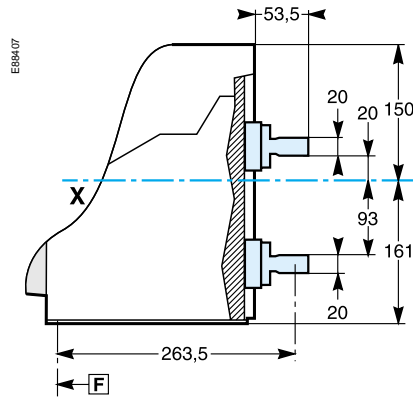
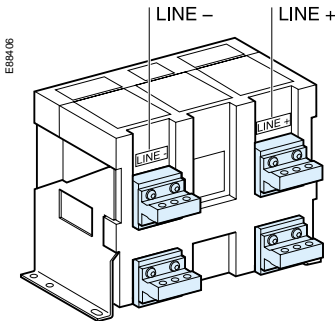

Vertical rear connection (NW10 - NW20)

Detail

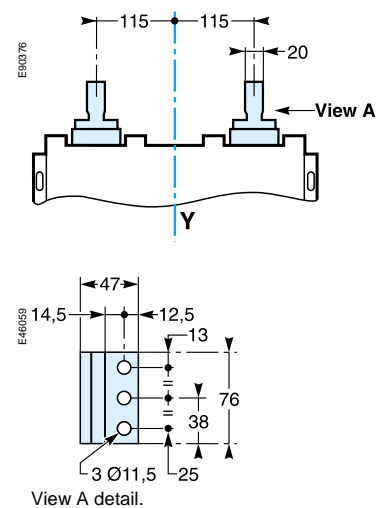
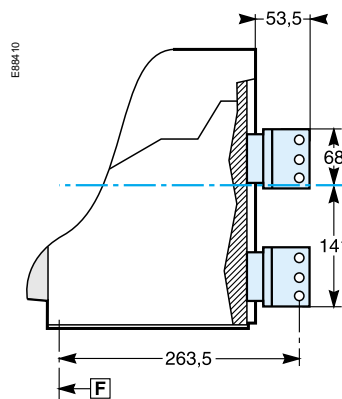
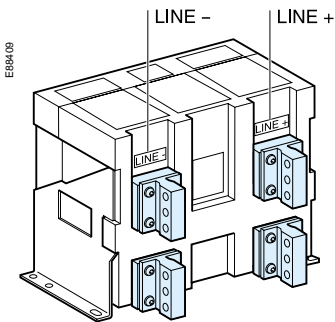

Vertical rear connection (NW40)

Detail

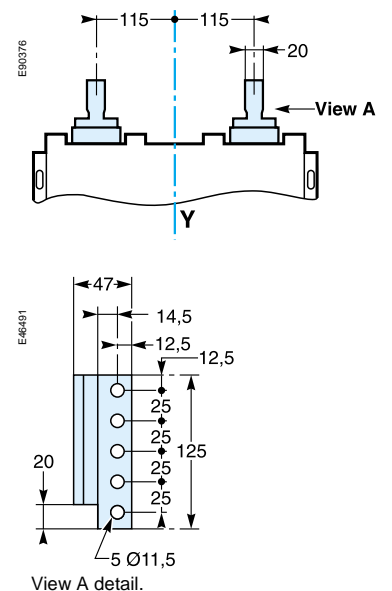
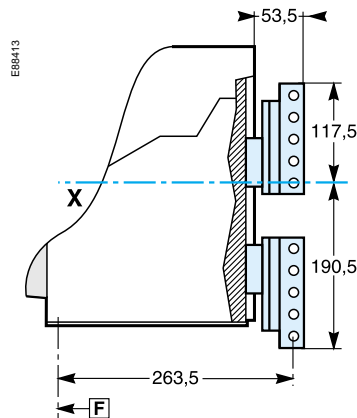
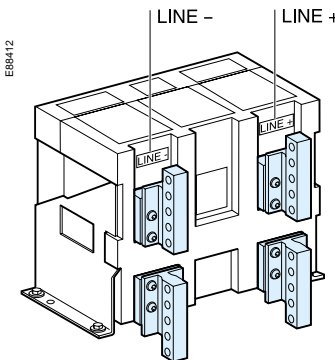

Note:
Recommended connection screws: **M10** class 8.8.
Tightening torque: **50 Nm** with contact washer.

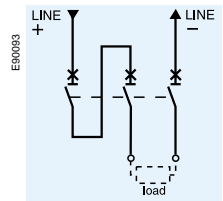

Connections

Horizontal rear connection (NW10 - NW20)

Detail

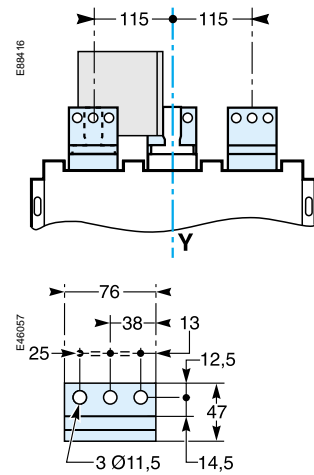
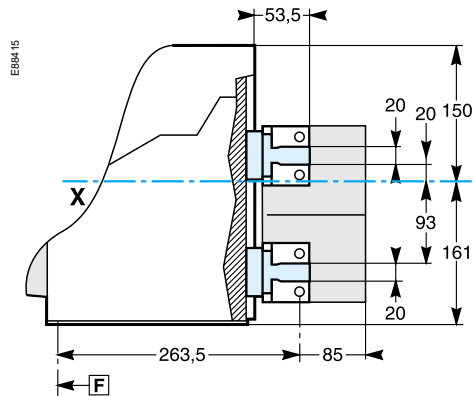
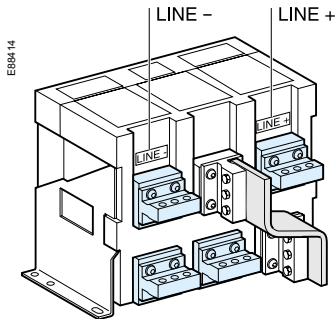

Vertical rear connection (NW10 - NW20)

Detail

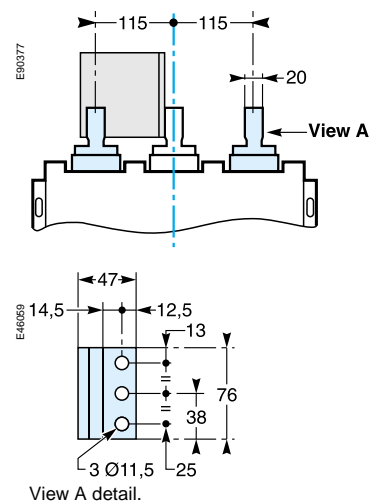
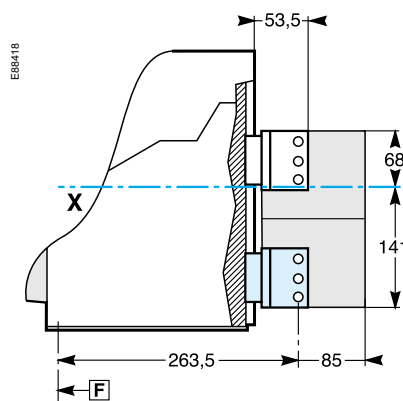
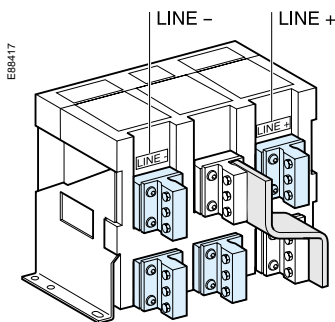

Vertical rear connection (NW40)

Detail

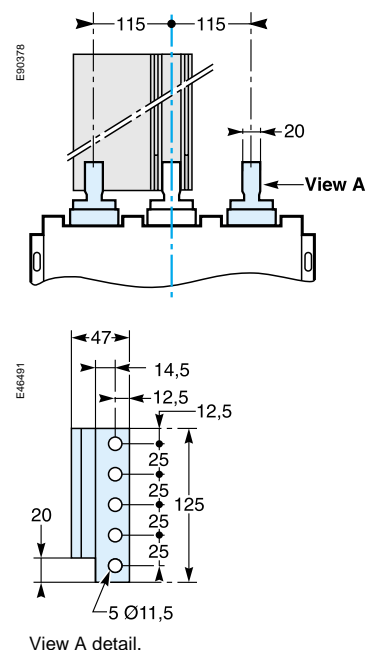
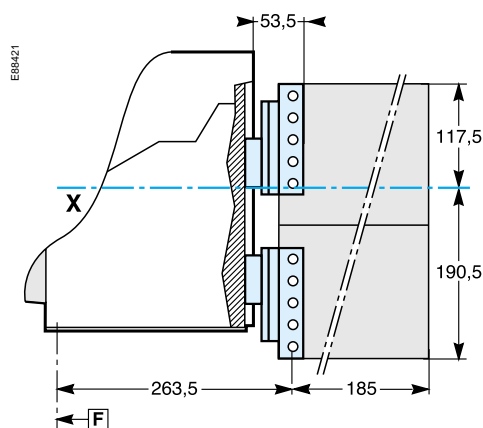
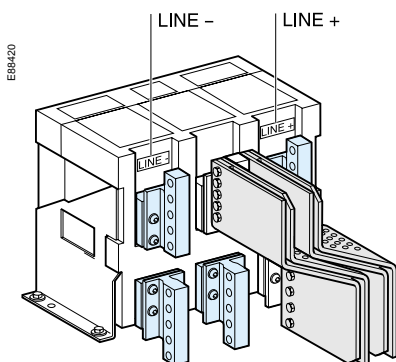

Note:
Recommended connection screws: **M10** class 8.8.
Tightening torque: **50 Nm** with contact washer.

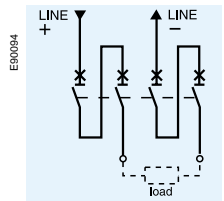

Connections

Horizontal rear connection (NW10 - NW20)

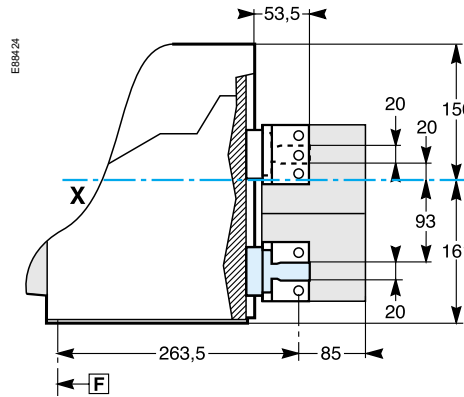
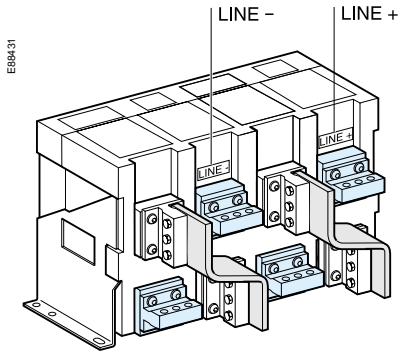

Detail

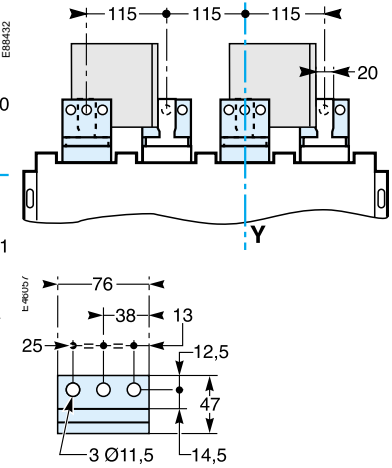

Vertical rear connection (NW10 - NW20)

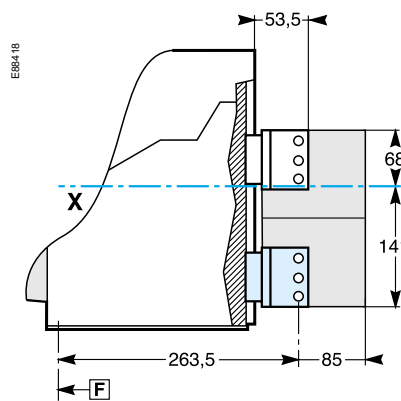
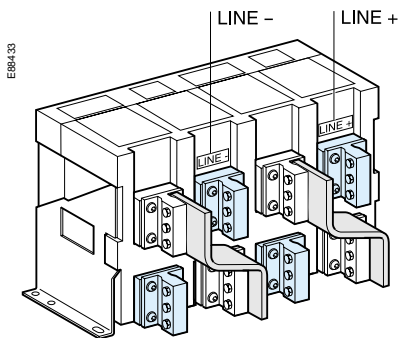

Detail

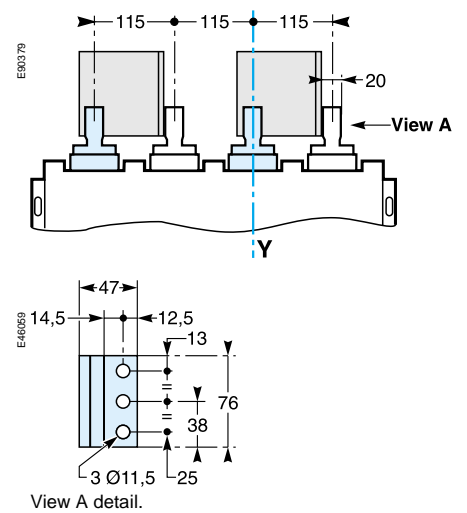

Vertical rear connection (NW40)

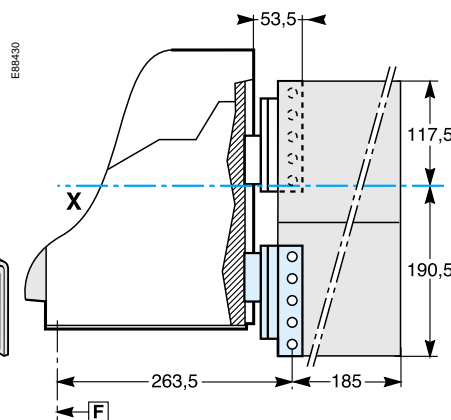
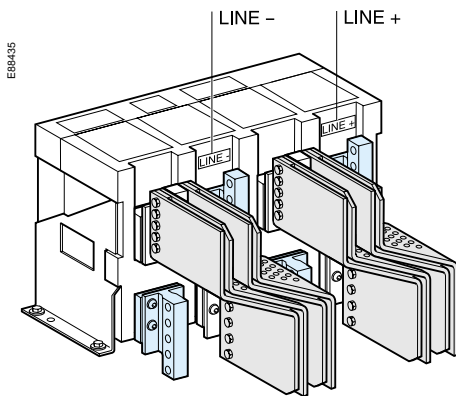

Detail

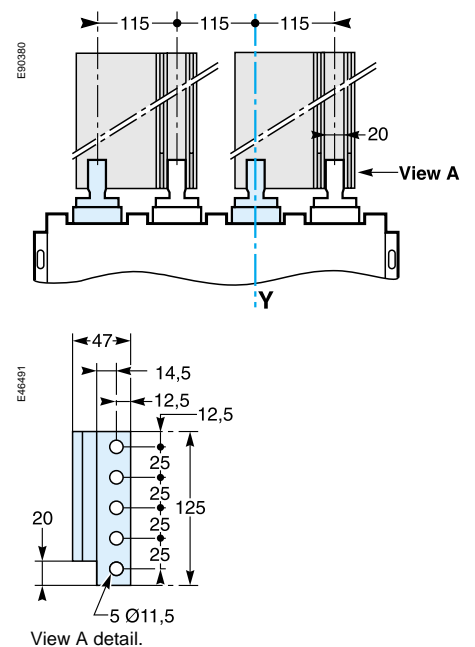

Note:
Recommended connection screws: **M10** class 8.8.
Tightening torque: **50 Nm** with contact washer.

Dimensions

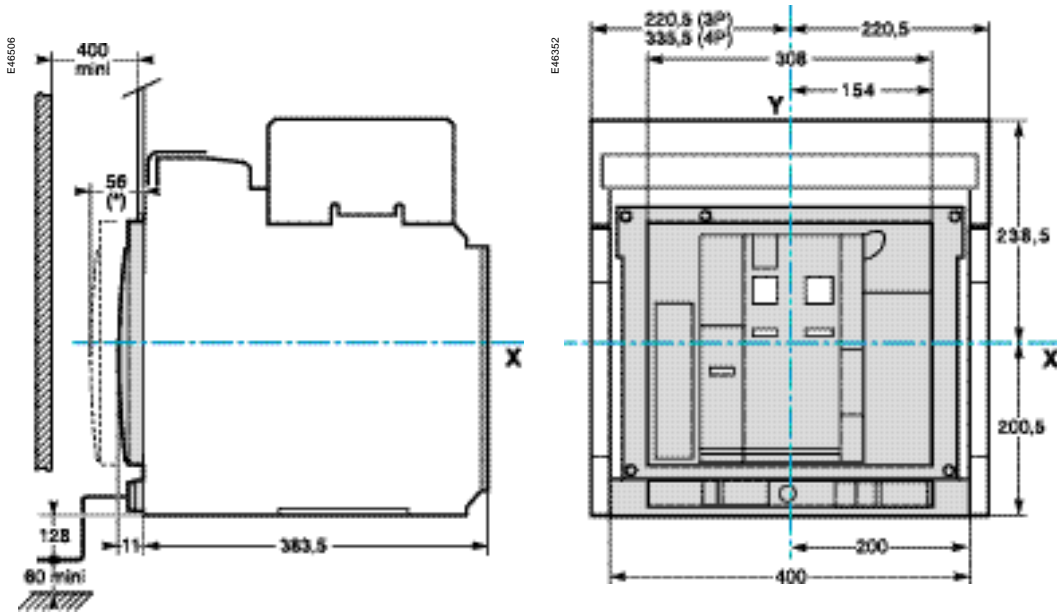

Mounting on base plate or rails

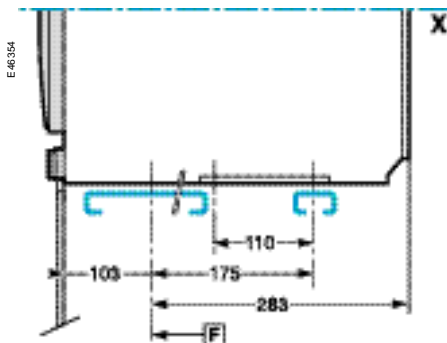

Mounting detail

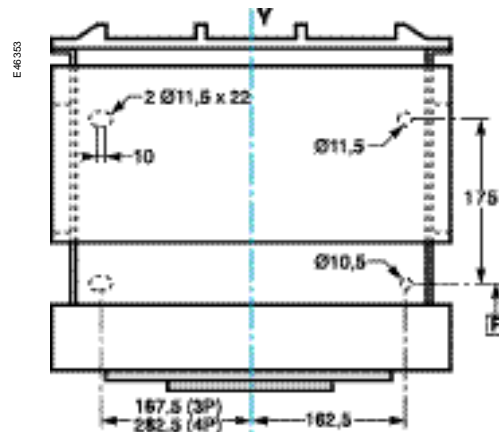

Safety clearances

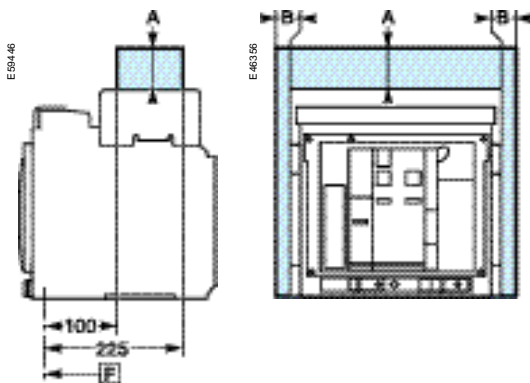

Door cutout

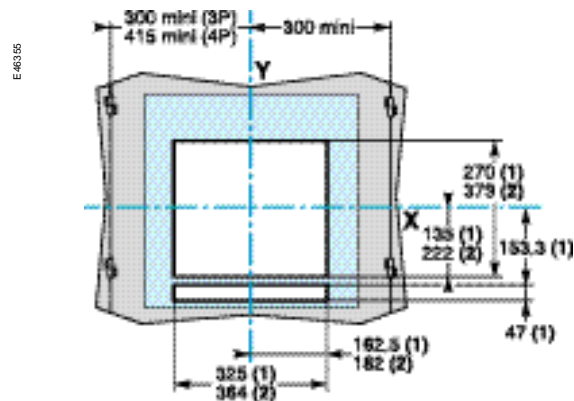

	Insulated parts	Metal parts	Energised parts
A	0	0	0
B	0	0	60

Note:
 (1) Without escutcheon
 (2) With escutcheon
 X and Y are the symmetry planes for a 3-pole device.

F: Datum.

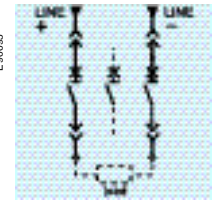

Connections

Horizontal rear connection (NW10 - NW20)

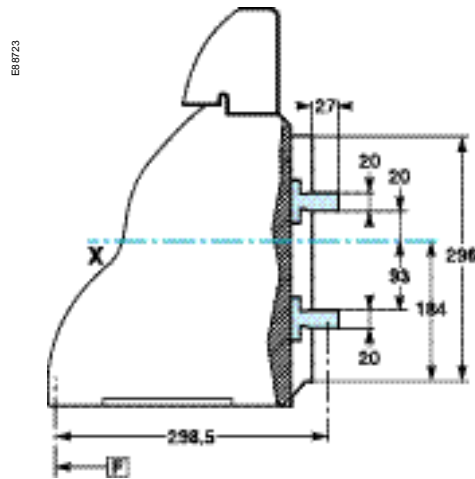
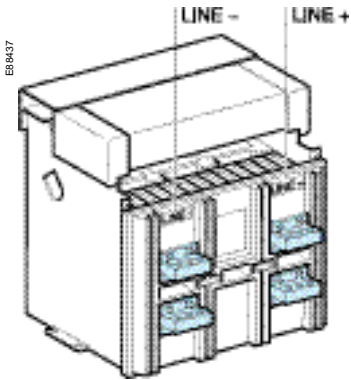

Detail

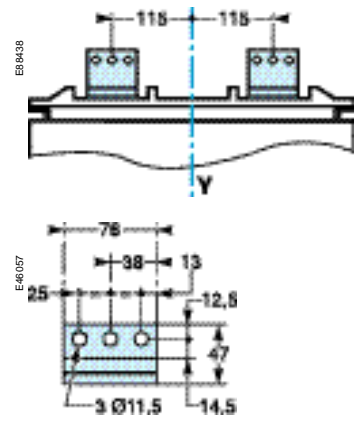

Vertical rear connection (NW10 - NW20)

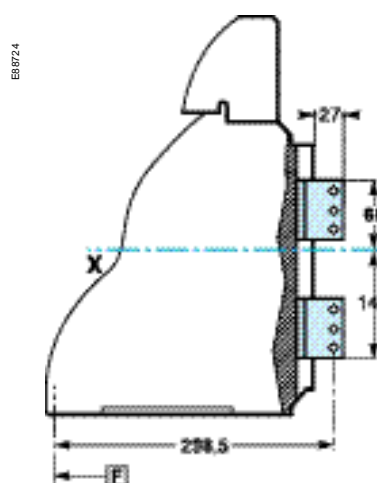
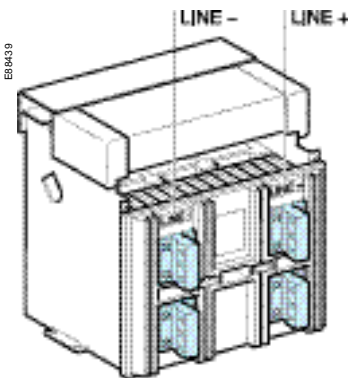

Detail



View A detail.

Vertical rear connection (NW40)

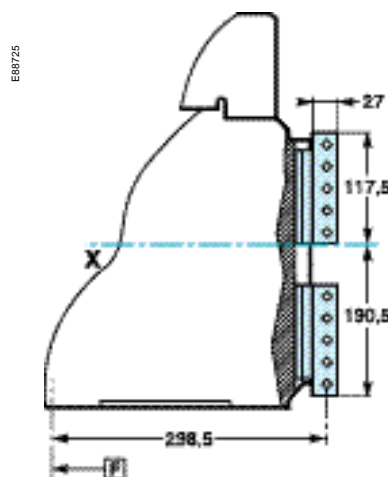
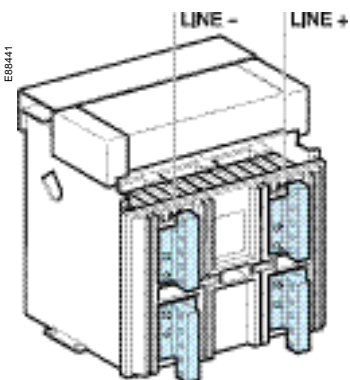

Detail

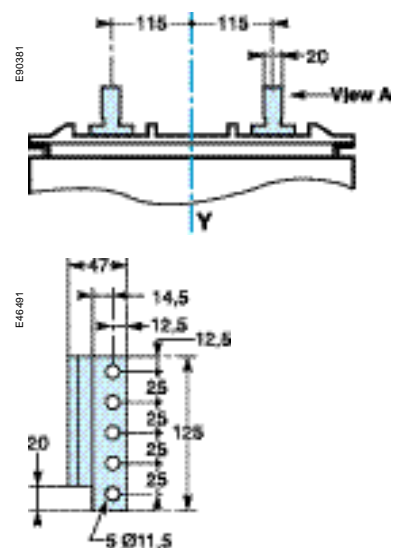

View A detail.

Note:
Recommended connection screws: **M10** class 8.8.
Tightening torque: **50 Nm** with contact washer.

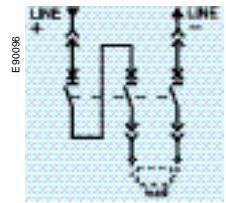

Connections

Horizontal rear connection (NW10 - NW20)

Detail

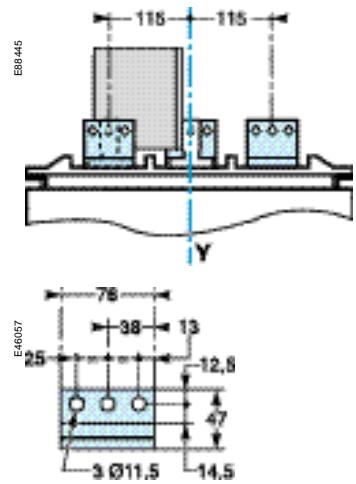
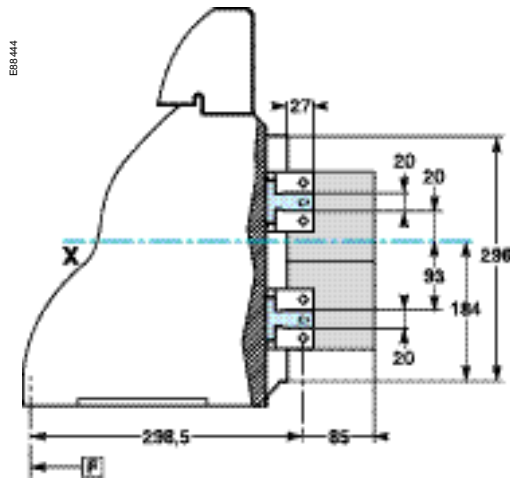
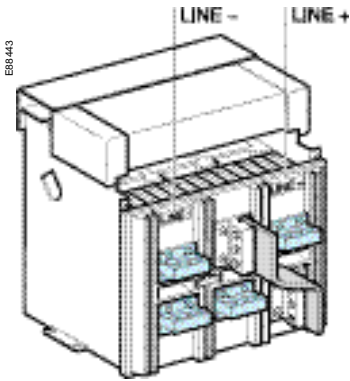

Vertical rear connection (NW10 - NW20)

Detail

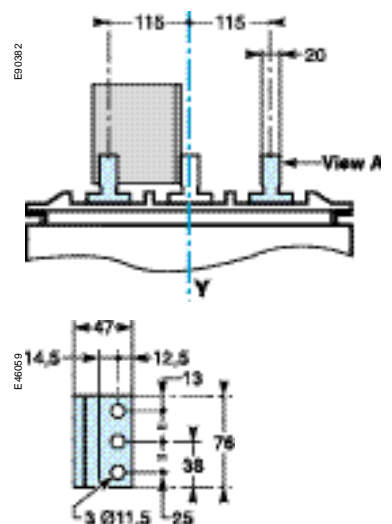
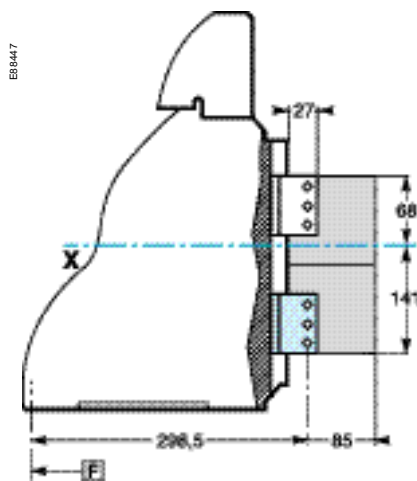
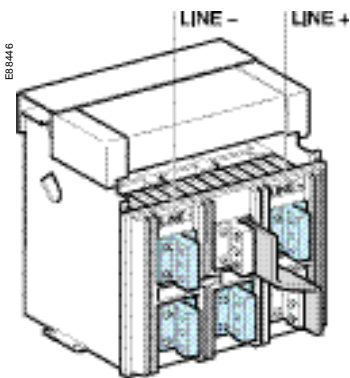

View A detail.

Vertical rear connection (NW40)

Detail

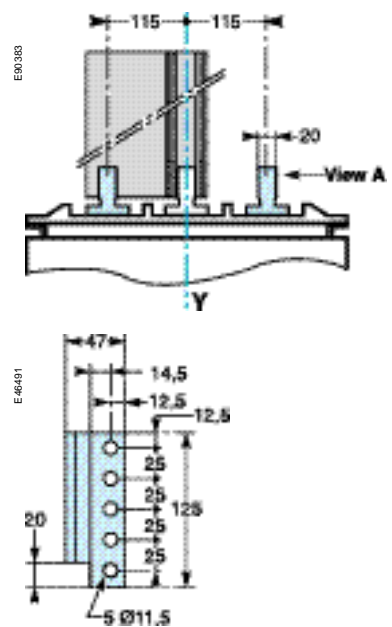
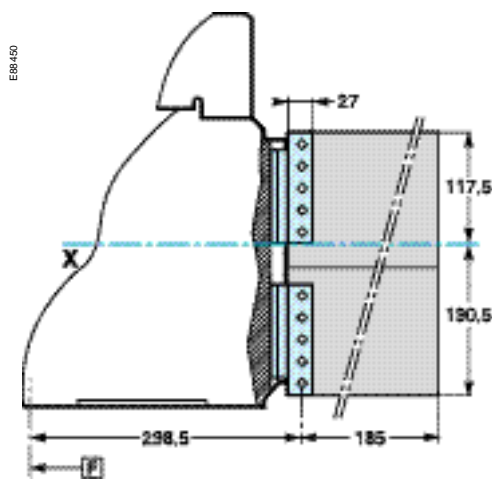
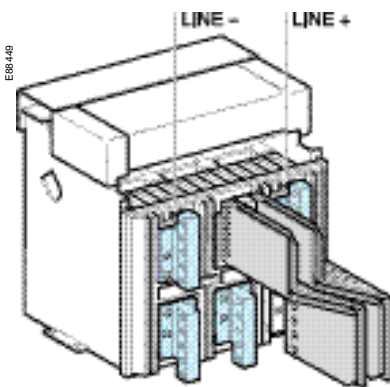

View A detail.

Note:
Recommended connection screws: **M10** class 8.8.
Tightening torque: **50 Nm** with contact washer.

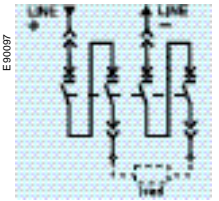

Connections

Horizontal rear connection (NW10 - NW20)

Detail

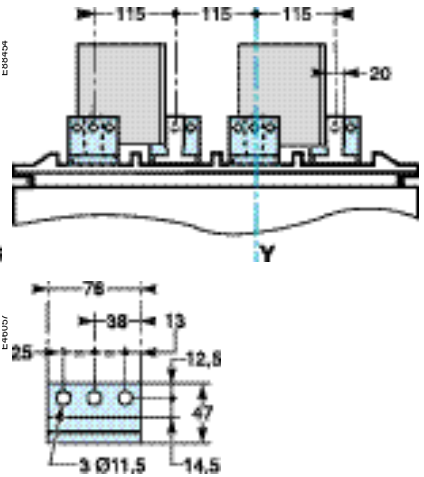
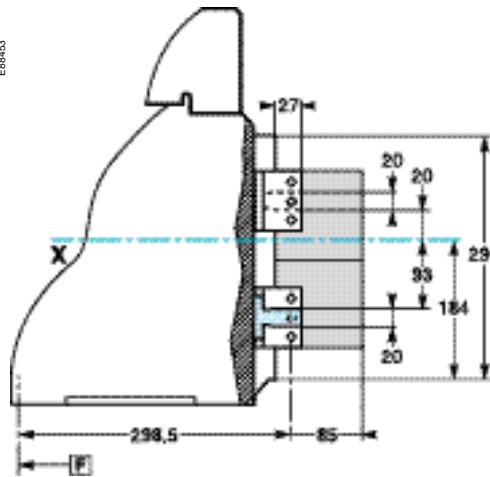
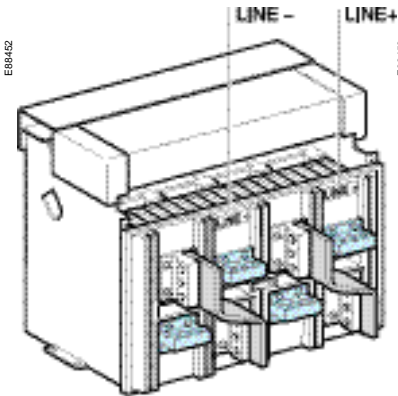

Vertical rear connection (NW10 - NW20)

Detail

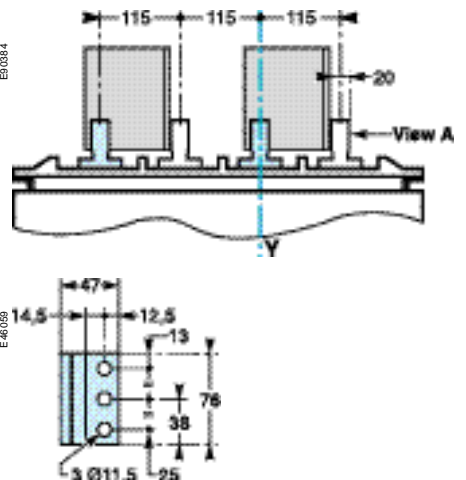
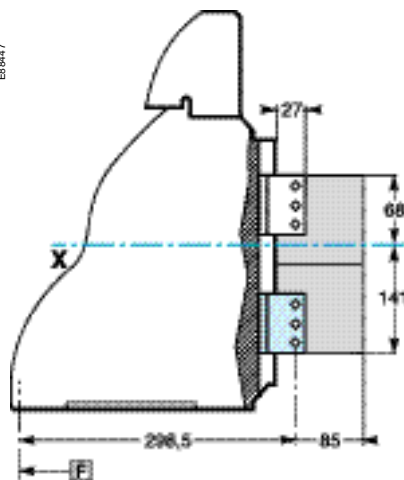
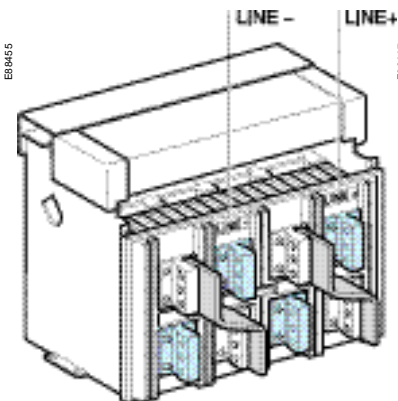

View A detail.

Vertical rear connection (NW40)

Detail

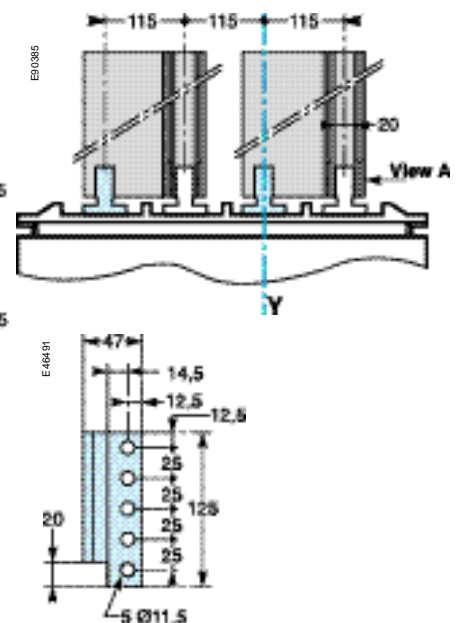
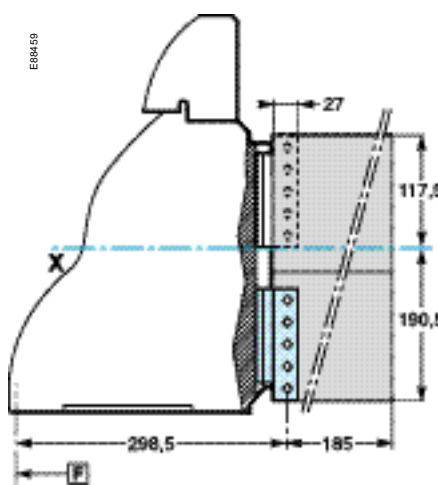
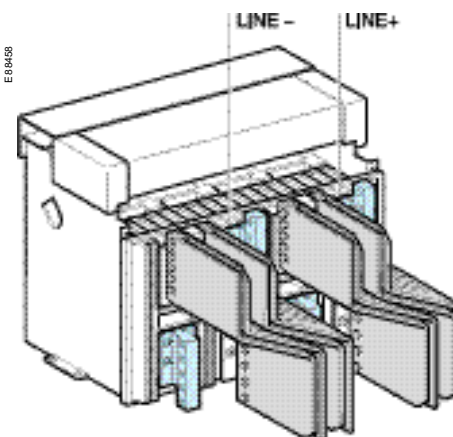

View A detail.

Note:
Recommended connection screws: **M10** class 8.8.
Tightening torque: **50 Nm** with contact washer.

Rear panel cutout (drawout devices)

NW10 to NW40

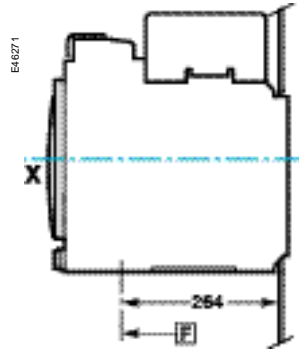
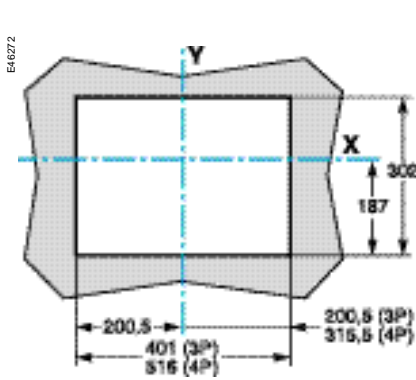

Escutcheon

Fixed device

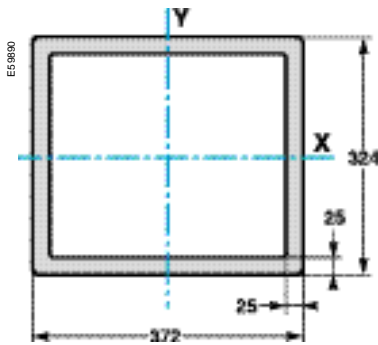

Drawout device

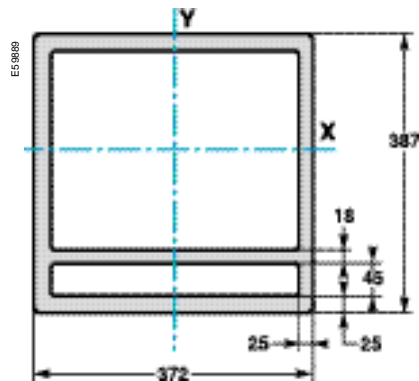

\square : Datum.

Connection of auxiliary wiring to terminal block

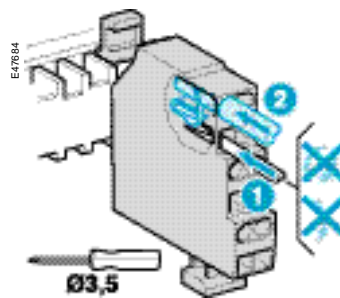
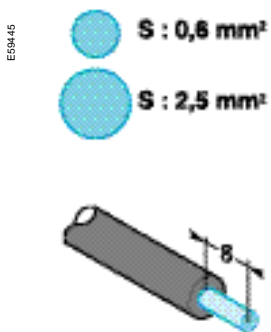

One conductor only per connection point.

Delay unit for MN release

MNR

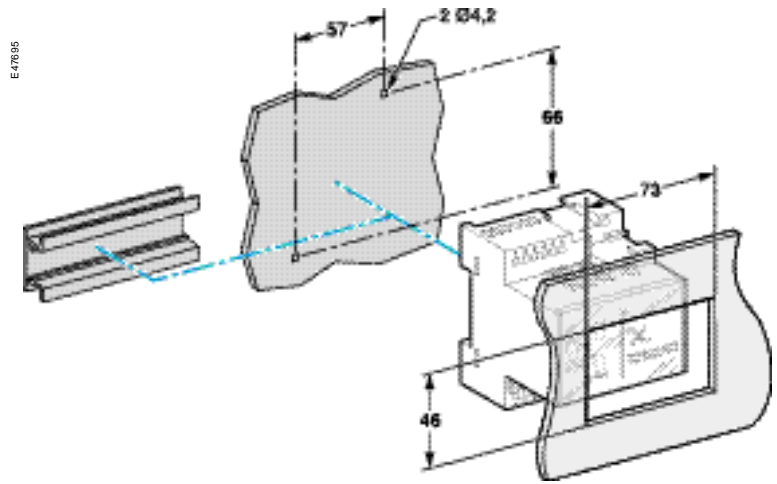
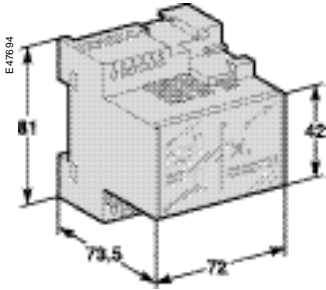

"Chassis" communication module

ModBUS

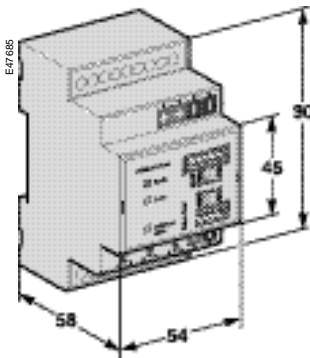

Digipact



Presentation	2
Functions and characteristics	5
Dimensions and connection	25
Masterpact NW10 to NW40 DC	38
Fixed and drawout devices	38
Communication option 24 V DC external power supply	40
Installation recommendations	43
Additional characteristics	55
Catalogue numbers	59

The diagram is shown with circuits de-energised, all devices open, connected and charged and relays in normal position.

Version C

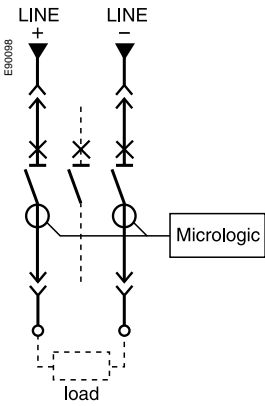

Version D

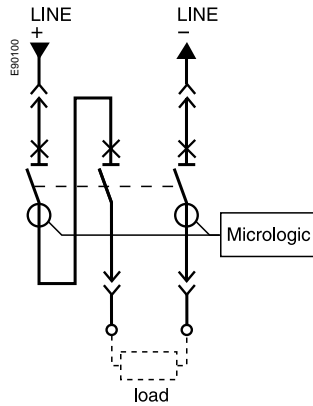

Remote operation

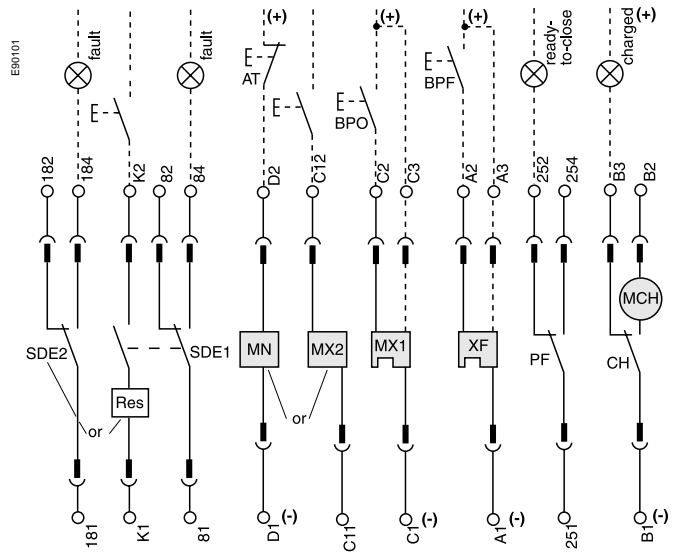

Version E

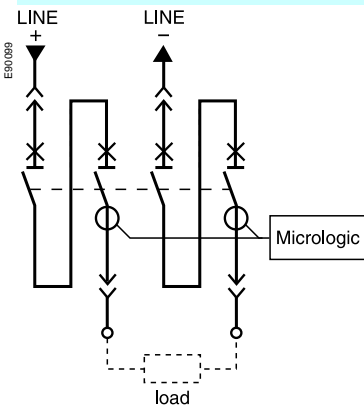

Terminal block marking	Control unit
	Com :E1-E6 communication
o o	E5 E6
o o	E3 E4
o o	E1 E2

SDE2 / Res	SDE1	MN / MX2	MX1	XF	PF	MCH
o o 184 / K2	o o 84	o o D2 / C12	o o C2	o o A2	o o 254	o o B2
o o 182	o o 82	o o	o o C3	o o A3	o o 252	o o B3
o o 181 / K1	o o 81	o o D1 / C11	o o C1	o o A1	o o 251	o o B1

- SDE2:** Fault-trip indication contact
or
- Res:** Remote reset
- SDE1:** Fault-trip indication contact (supplied as standard)
- MN:** Undervoltage release
or
- MX2:** Shunt release
- MX1:** Shunt release (standard or communicating)
- XF:** Closing release (standard or communicating)
- PF:** Ready-to-close contact
- MCH:** Electric motor

Note:
When communicating MX or XF releases are used, the third wire (C3,A3) must be connected even if the communication module is not installed.

Indication contacts

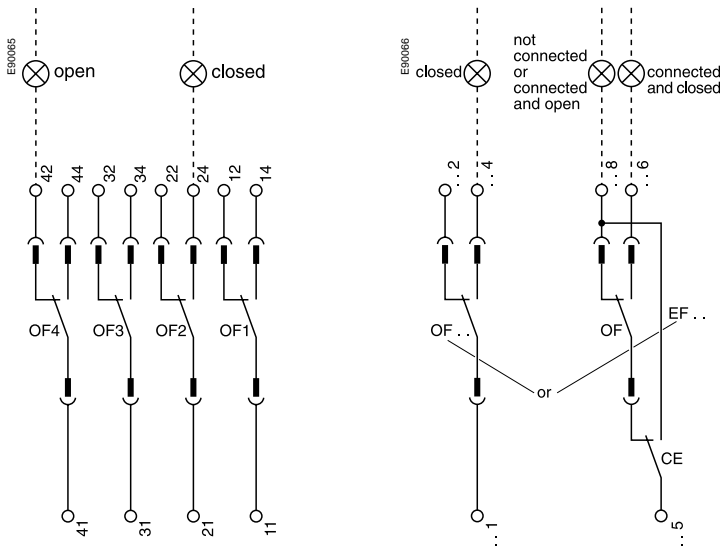

Chassis contacts

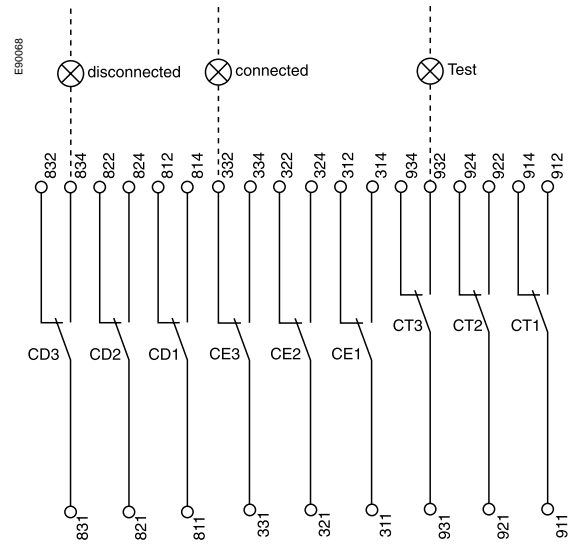

Indication contacts

OF4	OF3	OF2	OF1	OF24	OF23	OF22	OF21	OF14	OF13	OF12	OF11
44	34	24	14	244	234	224	214	144	134	124	114
42	32	22	12	242	232	222	212	142	132	122	112
41	31	21	11	241	231	221	211	141	131	121	111
or		or		or		or		or		or	
EF24	EF23	EF22	EF21	EF14	EF13	EF12	EF11				
248	238	228	218	148	138	128	118				
246	236	226	216	146	136	126	116				
245	235	225	215	145	135	125	115				

Chassis contacts

CD3	CD2	CD1	CE3	CE2	CE1	CT3	CT2	CT1
834	824	814	334	324	314	934	924	914
832	822	812	332	322	312	932	922	912
831	821	811	331	321	311	931	921	911
or		or		or		or		
CE6	CE5	CE4				CE9	CE8	CE7
364	354	344				394	384	374
362	352	342				392	382	372
361	351	341				391	381	371

Indication contacts

OF4 ON/OFF indication contacts	OF24 ON/OFF indication contacts
OF3 indication contacts	or
OF2	EF24 Combined "connected-closed" indication contacts
OF1	
	OF22 or EF22
	OF21 or EF21
	OF14 or EF14
	OF13 or EF13
	OF12 or EF12
	OF11 or EF11

Chassis contacts

CD3 Disconnected position contacts	CE3 Connected position contacts	CT3 Test position contacts
CD2 contacts	CE2 contacts	CT2 contacts
CD1	CE1	CT1
or		
CE6 Connected position contacts	CE5 contacts	CE4
CE9 Connected position contacts	CE8 contacts	CE7
or		
CD6 Disconnected position contacts	CD5 contacts	CD4

Key:

- Drawout device only
- SDE1, OF1, OF2, OF3, OF4 supplied as standard

Interconnected connections (only one wire per connection point)

Connection of the communications option

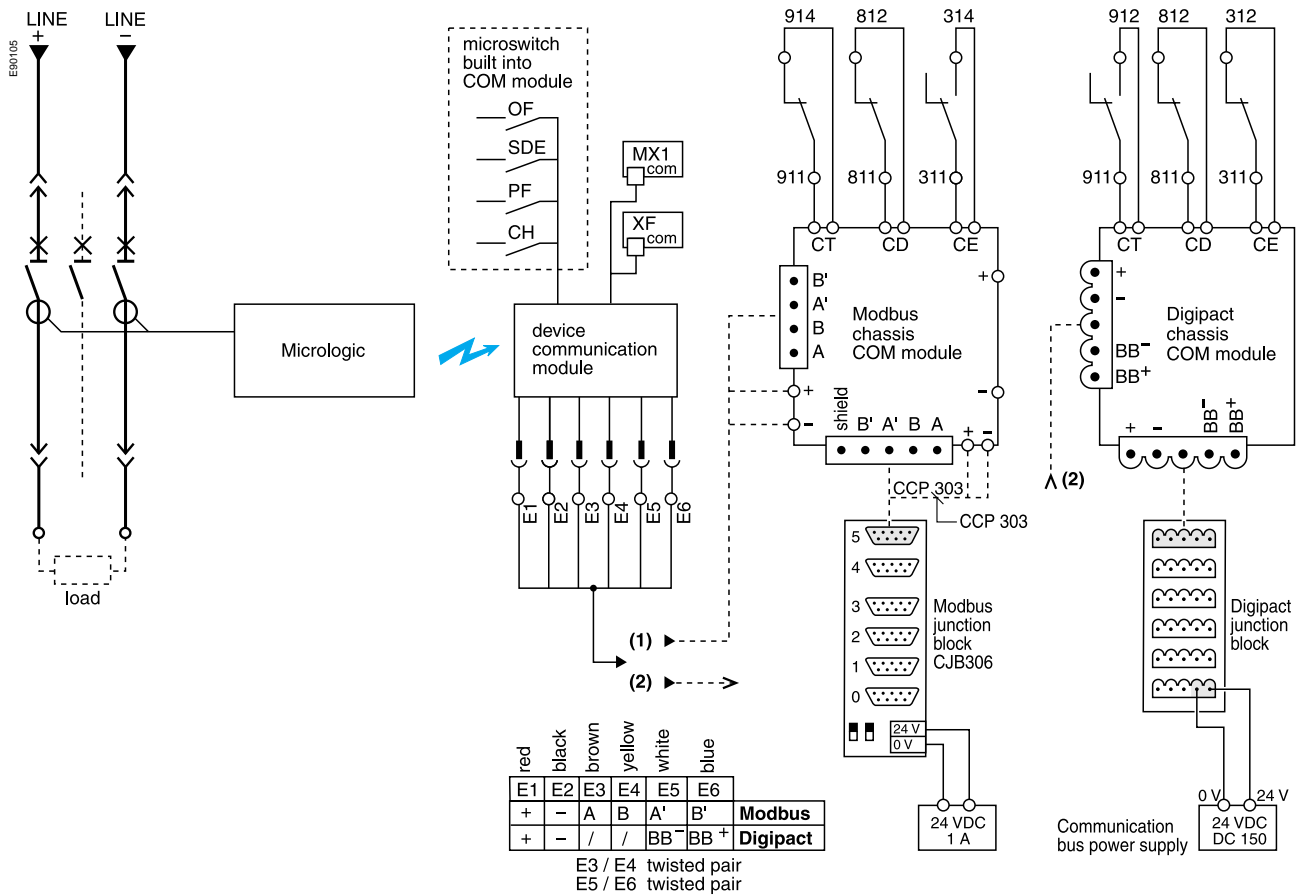

The communications bus requires its own 24 V DC power source (E1, E2).

(1) drawout device equipped with Modbus chassis COM module.
(2) drawout device equipped with Digipact chassis COM module.

Examples using the COM communications option

Communicating switchboard

This configuration provides remote display and control of Masterpacts equipped with the Modbus or Digipact COM module. The Digipact bus can be combined with the Modbus bus.

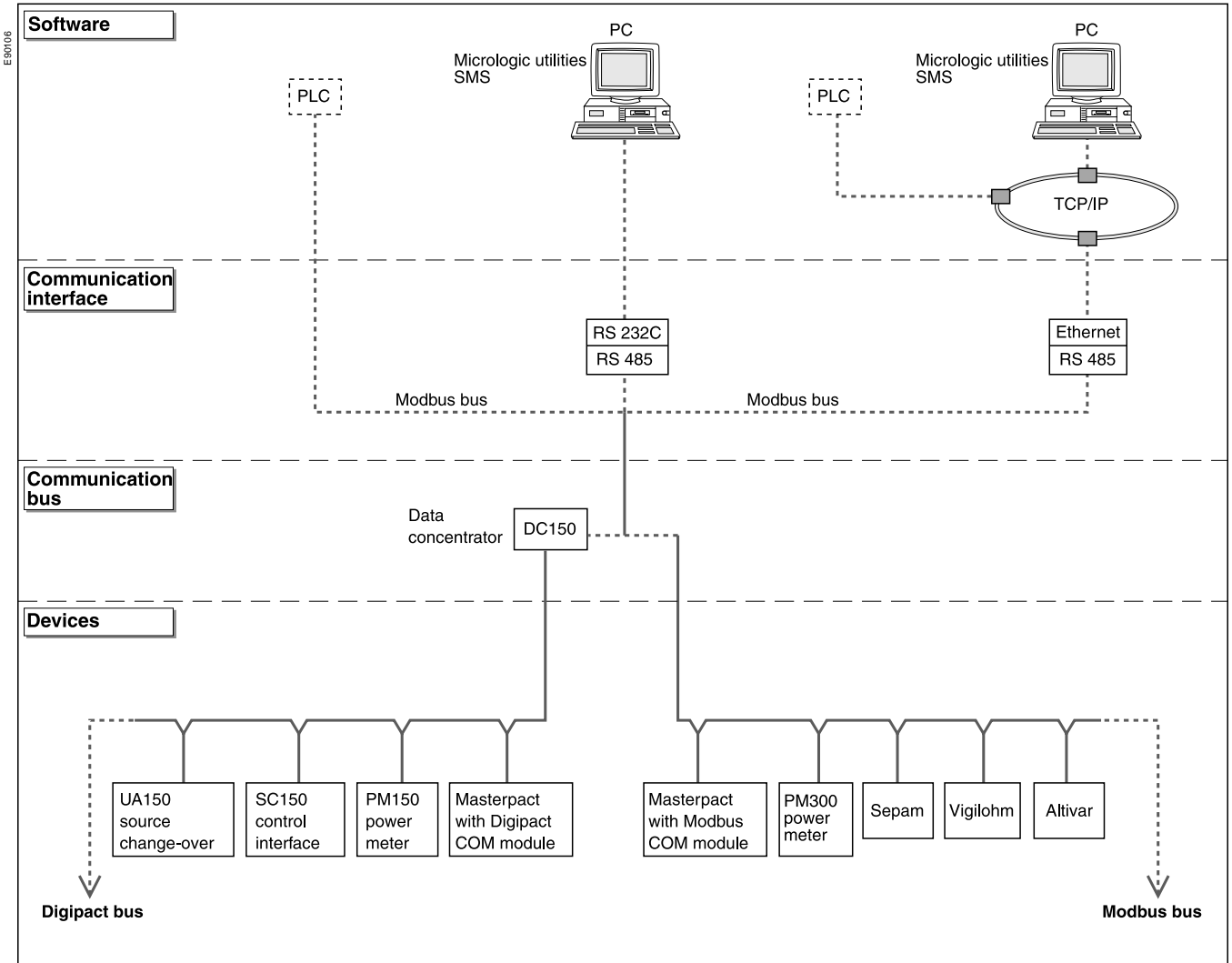



Presentation	2
Functions and characteristics	5
Dimensions and connection	25
Electrical diagrams	37
Operating conditions	44
Installation in switchboard	46
Door interlock catch	47
Cable-type door interlock	
Connection of MN, MX and XF voltage releases	48
Power connection	49
Busbar sizing	52
Temperature derating	
Power dissipation and input / output resistance	53
Additional characteristics	55
Catalogue numbers	59

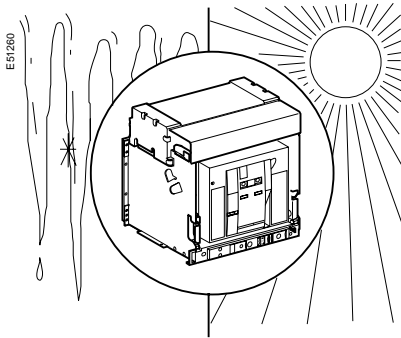

Ambient temperature

Masterpact NW DC devices can operate under the following temperature conditions:

- the electrical and mechanical characteristics are stipulated for an ambient temperature of -5°C to $+70^{\circ}\text{C}$
- circuit-breaker closing is guaranteed down to -35°C
- storage conditions are as follows:
 - -35°C to $+85^{\circ}\text{C}$ for a Masterpact NW DC device
 - -25°C to $+85^{\circ}\text{C}$ for the control unit.

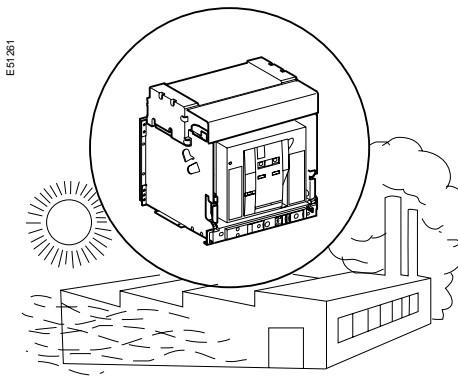

Extreme atmospheric conditions

Masterpact NW DC devices have successfully passed the tests defined by the following standards for extreme atmospheric conditions.

- Masterpact NW DC devices have successfully passed the tests defined by the following standards for extreme atmospheric conditions:
 - IEC 68-2-1: dry cold at -55°C ;
 - IEC 68-2-2: dry heat at $+85^{\circ}\text{C}$;
 - IEC 68-2-30: damp heat (temperature $+55^{\circ}\text{C}$, relative humidity 95%);
 - IEC 68-2-52 level 2: salt mist.

Masterpact devices can operate in the industrial environments defined by standard IEC 947 (pollution degree up to 4).

It is nonetheless advised to check that the devices are installed in suitably cooled switchboards without excessive dust.

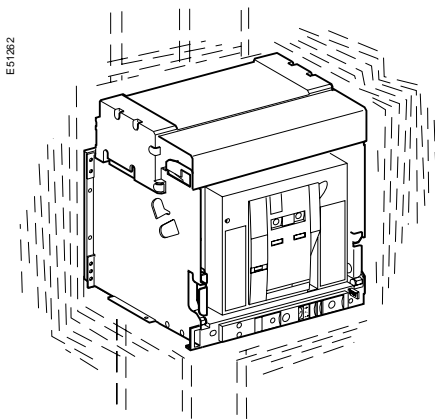

Vibrations

Masterpact NW DC devices are guaranteed against electromagnetic or mechanical vibrations.

Tests are carried out in compliance with standard IEC 68-2-6 for the levels required by merchant-marine inspection organisations (Veritas, Lloyd's, etc.):

- 2 to 13.2 Hz: amplitude $\pm 1\text{ mm}$;
- 13.2 to 100 Hz: constant acceleration 0.7 g.

Excessive vibration may cause tripping, breaks in connections or damage to mechanical parts.

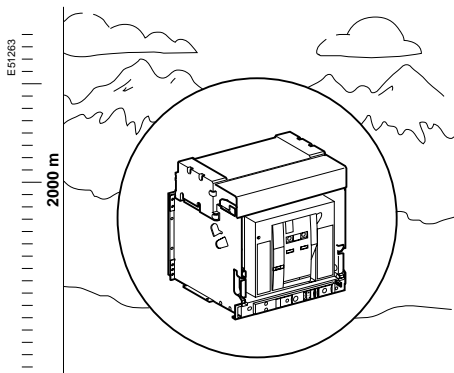

Altitude

Masterpact NW DC devices are designed for operations at altitudes under 2000 metres.

At altitudes higher than 2000 metres, the modifications in the ambient air (electrical resistance, cooling capacity) lower the following characteristics as follows:

Altitude (m)	2000	3000	4000	5000
Dielectric resistance voltage (V)	3500	3150	2500	2100
Average insulation level (V)	1000	900	700	600
Maximum utilisation voltage (V)	900	770	680	600
Average thermal current (A) at 40 °C	1 x I _n	0.99 x I _n	0.96 x I _n	0.94 x I _n

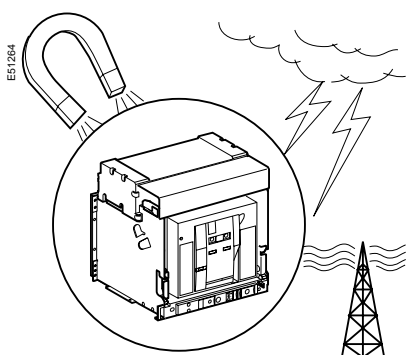

Electromagnetic disturbances

Masterpact NW DC devices are protected against:

- overvoltages caused by devices that generate electromagnetic disturbances
- overvoltages caused by atmospheric disturbances or by a distribution-system outage (e.g. failure of a lighting system)
- devices emitting radio waves (radios, walkie-talkies, radar, etc.)
- electrostatic discharges produced by users.

Masterpact NW DC devices have successfully passed the electromagnetic-compatibility tests (EMC) defined by the following international standards:

- IEC 60947-2, appendix F.

The above tests guarantee that:

- no nuisance tripping occurs
- tripping times are respected.

Possible positions

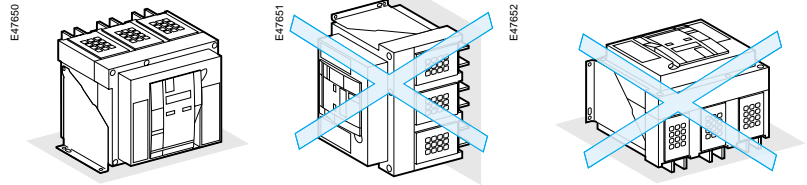

Power supply

The plus and minus polarities (**LINE + and LINE -**) of the power supply must be connected as indicated in the "Dimensions and connection" chapter.

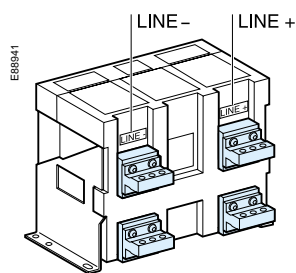

Mounting the circuit-breaker

It is important to distribute the weight of the device uniformly over a rigid mounting surface such as rails or a base plate. This mounting plane should be perfectly flat (tolerance on support flatness: 2 mm). This eliminates any risk of deformation which could interfere with correct operation of the circuit breaker. Masterpact devices can also be mounted on a vertical plane using the special brackets.

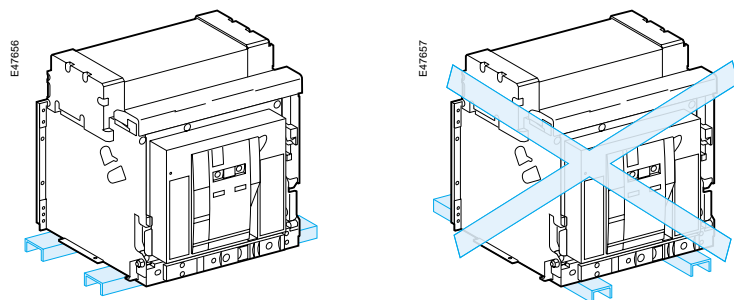

Mounting on rails.

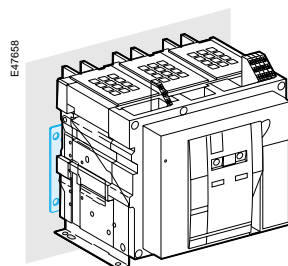

Mounting with vertical brackets.

Mounted on the right or left-hand side of the cradle, this device inhibits opening of the cubicle door when the circuit breaker is in "connected" or "test" position. If the breaker is put in the "connected" position with the door open, the door may be closed without having to disconnect the circuit breaker.

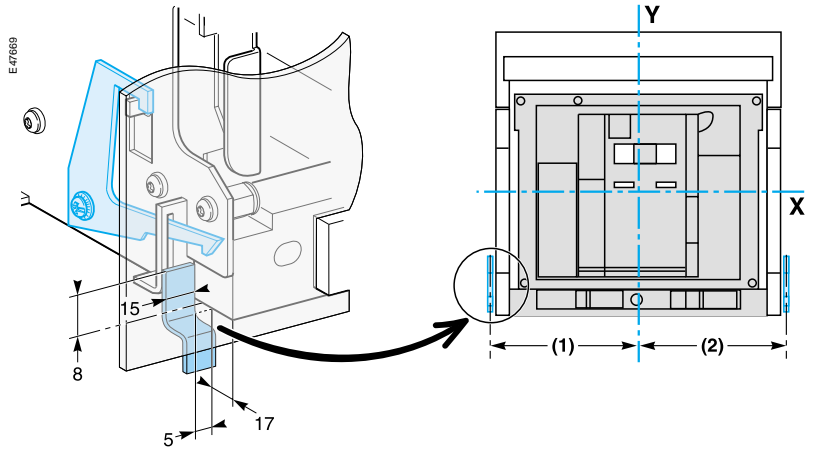

Dimensions (mm)

Type	(1)	(2)
NW10-40 (versions C-D)	215	215
NW10-40 (version E)	330	215

Breaker in "connected" or "test" position

Door cannot be opened

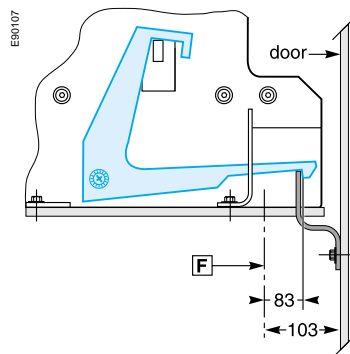

Breaker in "disconnected" position

Door can be opened

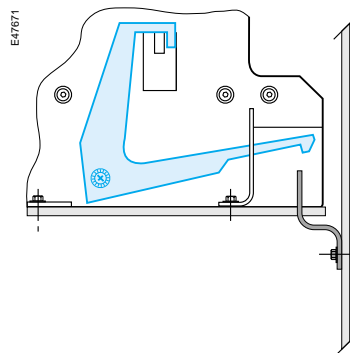

Note:
The door interlock can either be mounted on the right side or the left side of the breaker.

F: Datum.

Cable-type door interlock Connection of MN, MX and XF voltage releases

Cable-type door interlock

This option prevents door opening when the circuit breaker is closed and prevents circuit breaker closing when the door is open.

For this, a special plate associated with a lock and a cable is mounted on the right side of the circuit breaker.

With this interlock installed, the source changeover function cannot be implemented.

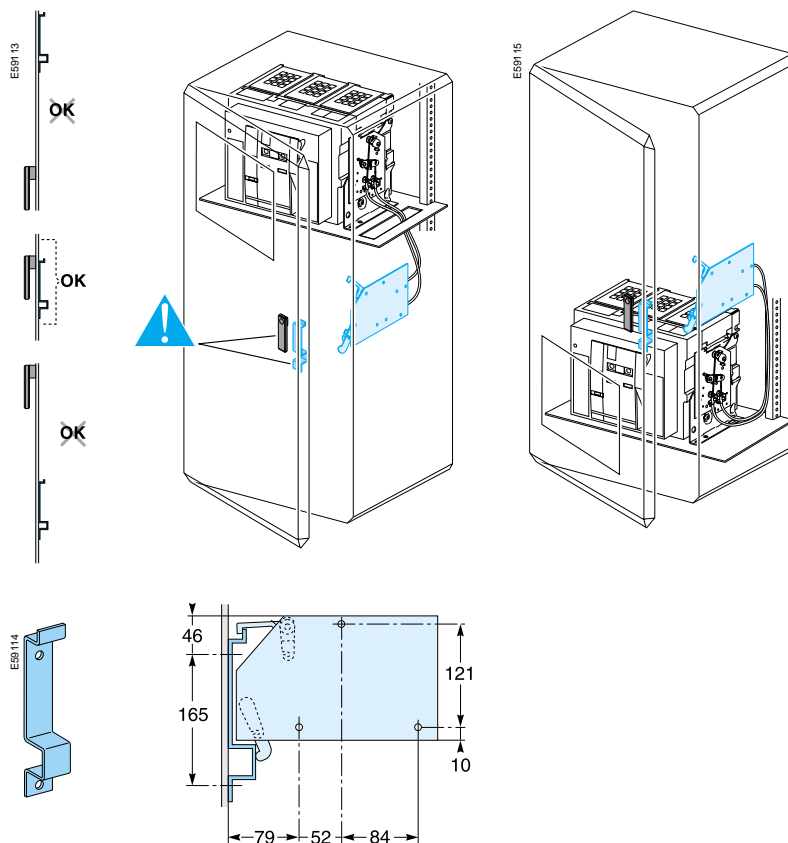

Wiring of voltage releases

During pick-up, the power consumed is approximately 150 to 200 VA. For low control voltages (12, 24, 48 V), maximum cable lengths are imposed by the voltage and the cross-sectional area of cables.

Recommended maximum cable lengths (meter)

		12 V		24 V		48 V	
		2.5 mm ²	1.5 mm ²	2.5 mm ²	1.5 mm ²	2.5 mm ²	1.5 mm ²
MN	U source 100 %	-	-	58	35	280	165
	U source 85 %	-	-	16	10	75	45
MX-XF	U source 100 %	21	12	115	70	550	330
	U source 85 %	10	6	75	44	350	210

Note: the indicated length is that of each of the two wires.

Cable connections

If cables are used for the power connections, make sure that they do not apply excessive mechanical forces to the circuit breaker terminals.

For this, make the connections as follows:

- extend the circuit breaker terminals using short bars designed and installed according to the recommendations for bar-type power connections:
 - for a single cable, use solution **B** opposite
 - for multiple cables, use solution **C** opposite.
- in all cases, follow the general rules for connections to busbars:
 - position the cable lugs before inserting the bolts
 - the cables should firmly secured to the framework of the switchboard (**E**).

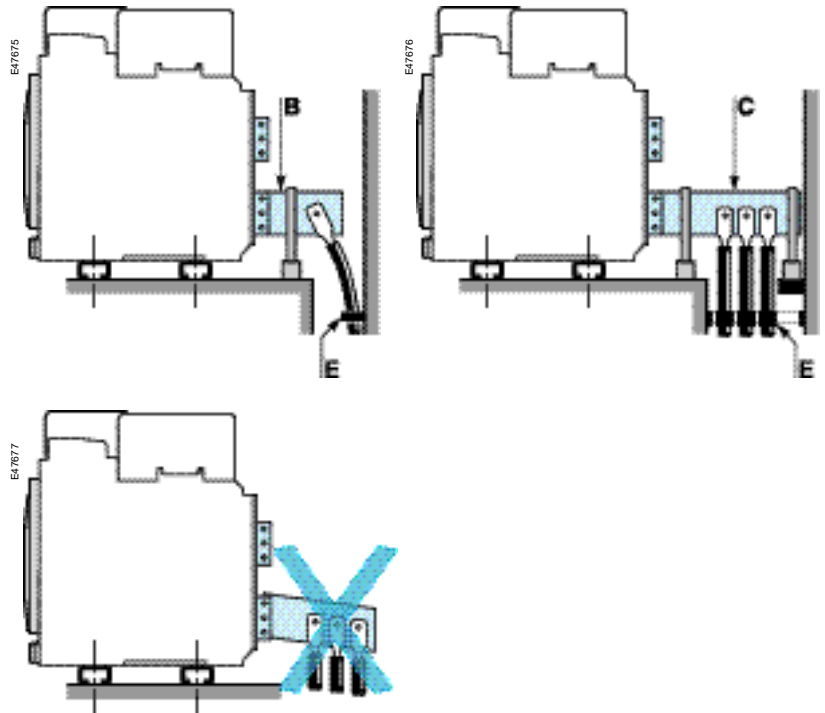

Busbar connections

The busbars should be suitably adjusted to ensure that the connection points are positioned on the terminals before the bolts are inserted **B**

The connections are held by the support which is solidly fixed to the framework of the switchboard, such that the circuit breaker terminals do not have to support its weight **C**. (This support should be placed close to the terminals).

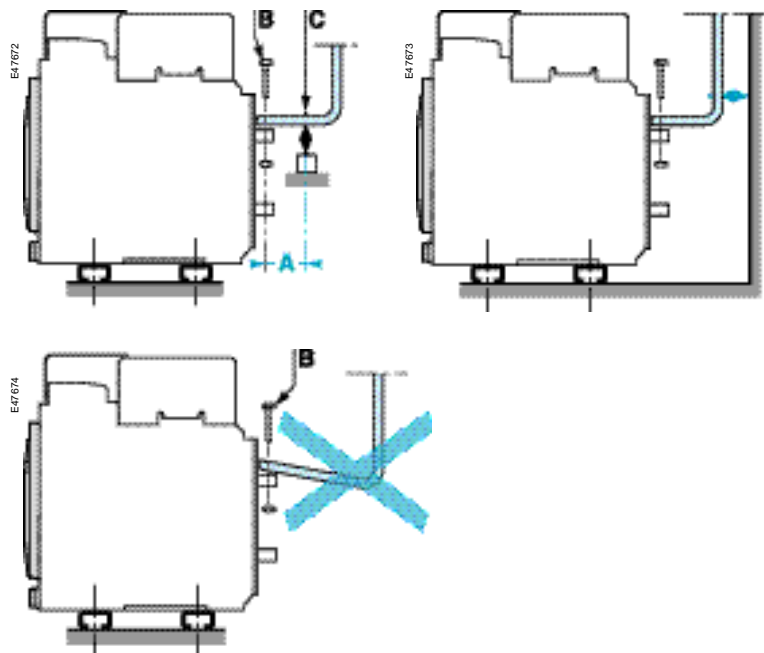

Electrodynamic stresses

The first busbar support or spacer shall be situated within a maximum distance from the connection point of the breaker (see table below). This distance must be respected so that the connection can withstand the electrodynamic stresses between phases in the event of a short circuit.

Maximum distance A between busbar to circuit breaker connection and the first busbar support or spacer with respect to the value of the prospective short-circuit current.					
Isc (kA)	30	50	65	80	100
distance A (mm)	350	300	250	150	150

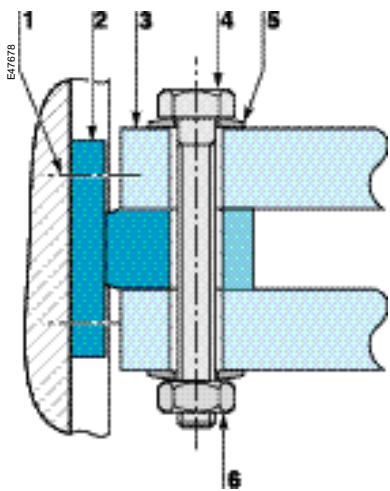

- 1 terminal screw factory-tightened to 16 Nm
- 2 breaker terminal
- 3 busbar
- 4 bolt
- 5 washer
- 6 nut

Clamping

Correct clamping of busbars depends amongst other things, on the tightening torques used for the nuts and bolts. Over-tightening may have the same consequences as under-tightening.

For connecting busbars (Cu ETP-NFA51-100) to the circuit breaker, the tightening torques to be used are shown in the table below.

These values are for use with copper busbars and steel nuts and bolts, class 8.8. The same torques can be used with AGS-T52 quality aluminium bars (French standard NFA 02-104 or American National Standard H-35-1).

Examples

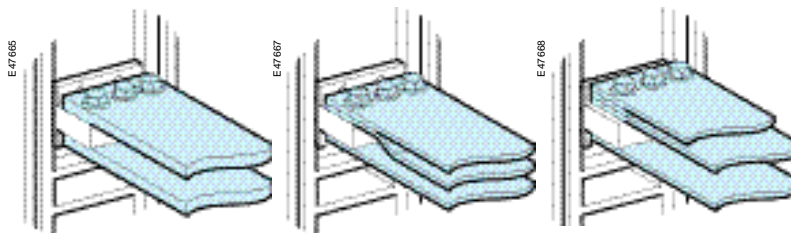

Tightening torques			
Ø Nominal (mm)	Ø Drilling (mm)	Tightening torque (Nm) with flat washers or split lockwashers	Tightening torque (Nm) with contact or serrated washers
10	11	37.5	50

Busbar drilling

Examples



Isolation distance

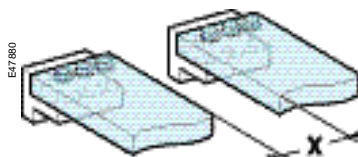

Dimensions (mm)

Ui	X min.
500 V DC	8 mm
900 V DC	14 mm

Busbar bending

When bending busbars maintain the radius indicated below(a smaller radius would cause cracks).

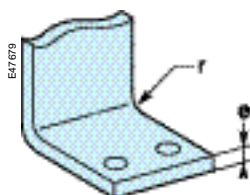

Dimensions (mm)

e	Radius of curvature r	
	Min.	Recommended
5	5	7.5
10	15	18 to 20

Horizontal rear connection NW10 to NW20 DC

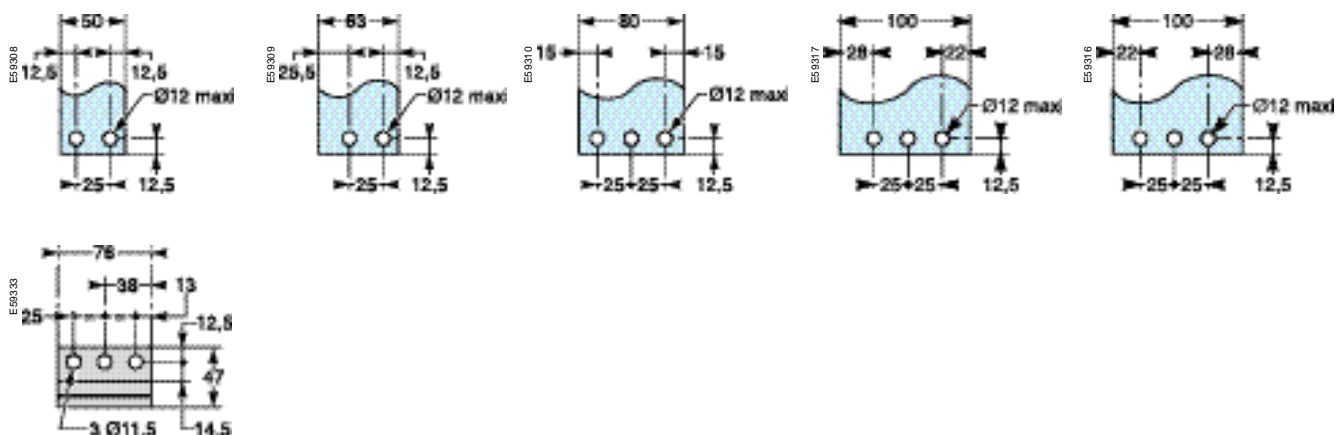

Vertical rear connection NW10 to NW20 DC

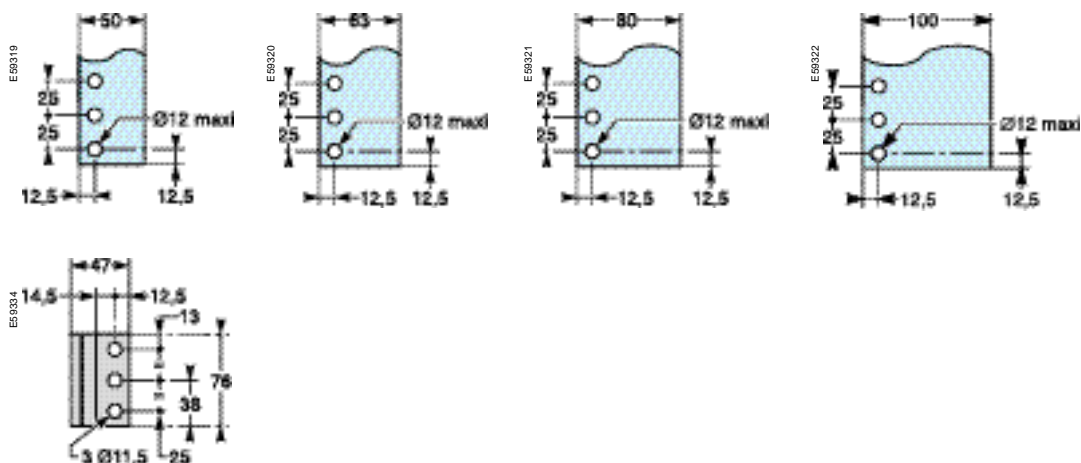

Vertical rear connection NW40 DC

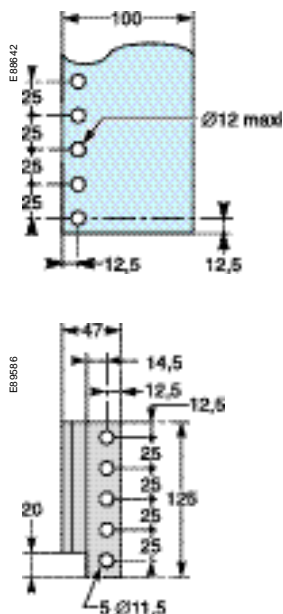

EB8643

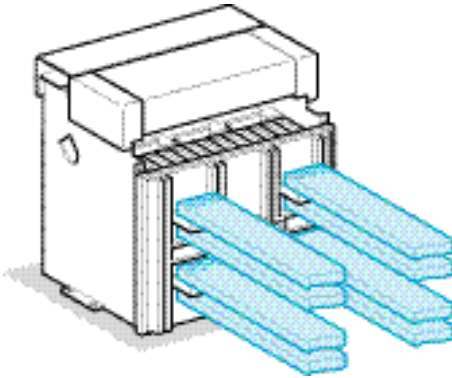

Rear horizontal connection

Basis of tables:

- maximum permissible busbar temperature: 100 °C
- Ti: temperature around the circuit breaker and its connections
- busbar material is unpainted copper.

Example

Conditions:

- drawout version
- horizontal busbars
- Ti: 50 °C
- service current: 2000 A.

Solution:

For Ti = 50 °C, use an NW20 DC which can be connected with three 100 x 5 mm bars or two 80 x 10 mm bars.

Masterpact	Maximum service current	Ti : 40 °C no. of bars		Ti : 50 °C no. of bars		Ti : 60 °C no. of bars	
		5 mm thick bars	10 mm thick bars	5 mm thick bars	10 mm thick bars	5 mm thick bars	10 mm thick bars
NW10	1000	3b.50 x 5	1b.63 x 10	3b.50 x 5	2b.50 x 10	3b.63 x 5	2b.50 x 10
NW20	2000	3b.100 x 5	2b.80 x 10	3b.100 x 5	2b.80 x 10	3b.100 x 5	3b.63 x 10

Note: the values indicated in these tables have been extrapolated from test data and theoretical calculations. These tables are only intended as a guide and cannot replace industrial experience or a temperature rise test.

EB8721

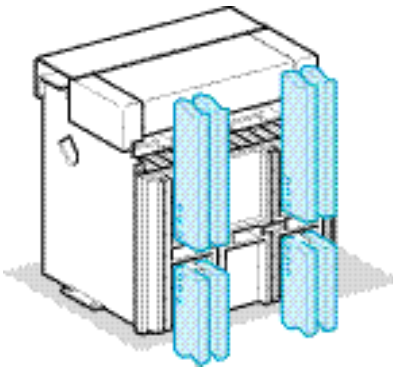

Rear vertical connection

Basis of tables:

- maximum permissible busbar temperature: 100 °C
- Ti: temperature around the circuit breaker and its connections
- busbar material is unpainted copper.

Example

Conditions:

- fixed version
- vertical busbars
- Ti: 40 °C
- service current: 1000 A.

Solution:

For Ti = 40 °C, use an NW10 DC which can be connected with two 50 x 5 mm bars or one 50 x 10 mm bar.

Masterpact	Maximum service current	Ti : 40 °C no. of bars		Ti : 50 °C no. of bars		Ti : 60 °C no. of bars	
		5 mm thick bars	10 mm thick bars	5 mm thick bars	10 mm thick bars	5 mm thick bars	10 mm thick bars
NW10	1000	2b.50 x 5	1b.50 x 10	2b.50 x 5	1b.50 x 10	2b.63 x 5	1b.63 x 10
NW20	2000	2b.100 x 5	2b.63 x 10	2b.100 x 5	2b.63 x 10	3b.100 x 5	3b.80 x 10
NW40	4000	-	4b.100 x 10	-	4b.100 x 10	-	4b.100 x 10

Note: the values indicated in these tables have been extrapolated from test data and theoretical calculations. These tables are only intended as a guide and cannot replace industrial experience or a temperature rise test.

Temperature derating Power dissipation and input / output resistance

Temperature derating

The table below indicates the maximum current rating, for each connection type, as a function of the ambient temperature around the circuit breaker and the busbars. For ambient temperatures greater than 60 °C, consult us.

Ti: temperature around the circuit breaker and its connections.

Version	Drawout device										Fixed device											
	Rear horizontal					Rear vertical					Rear horizontal					Rear vertical						
temp. Ti	40	45	50	55	60	40	45	50	55	60	40	45	50	55	60	40	45	50	55	60		
NW10 Version C	1000					1000					1000					1000						
Version D	1000					1000					1000					1000						
Version E	1000					1000					1000					1000						
NW20 Version C	2000					2000					2000					2000						
Version D	2000					2000					2000					2000						
Version E	2000					2000					2000					2000						
NW40 Version C	-					4000					-					4000						
Version D	-					4000					3900			3750		3600		-				
Version E	-					4000					3800			3650		3500		-				

Power dissipation and input/output resistance

Total power dissipation is the value measured at I_N, for a 3 pole (version C, D) or 4 pole (version E) breaker (values above the power P = 3RI²).

The resistance between input / output is the value measured per pole (cold state).

Version	Drawout device						Fixed device					
	Power dissipation (Watt)			Input/output resistance (µohm)			Power dissipation (Watt)			Input/output resistance (µohm)		
version	C	D	E	C	D	E	C	D	E	C	D	E
NW10	45	75	105	46	73	102	25	40	60	22	40	58
NW20	135	230	330	34	58	82	90	160	235	22	40	58
NW40	460	800	1150	29	50	72	360	580	850	22	36	52



Presentation	2
Functions and characteristics	5
Dimensions and connection	25
Electrical diagrams	37
Installation recommendations	43
Tripping curves	56
U = 500 V DC, L/R = 15 ms	56
U = 900 V DC, L/R = 15 ms	57
Catalogue numbers	59

Micrologic DC 1.0 instantaneous protection

With 1250 - 2500 A sensors

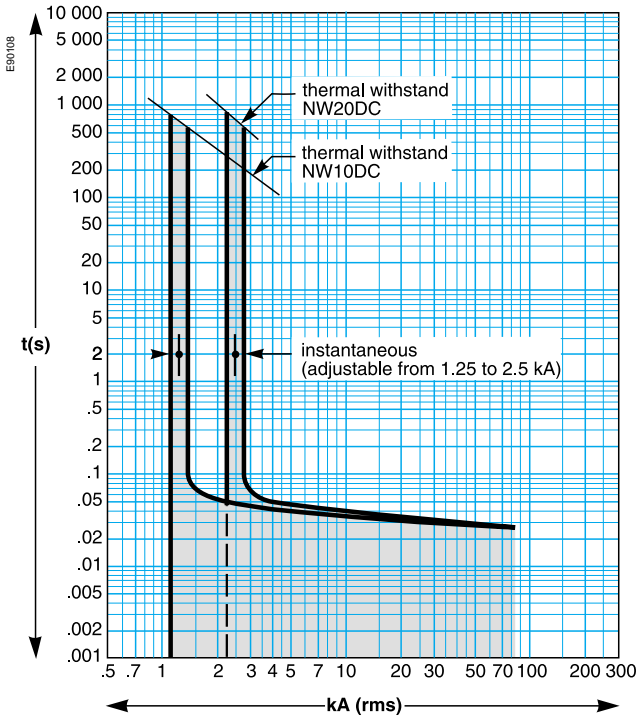

With 2500 - 5400 A sensors

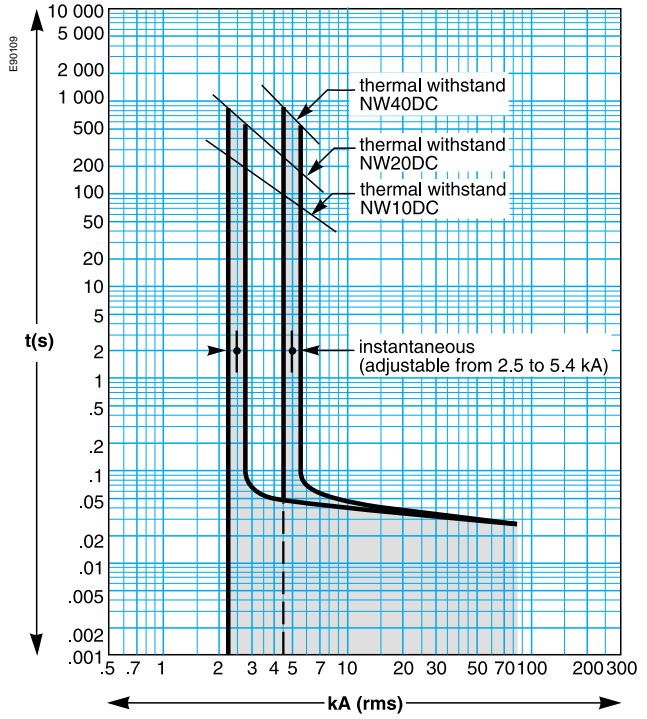

With 5000 - 11000 A sensors

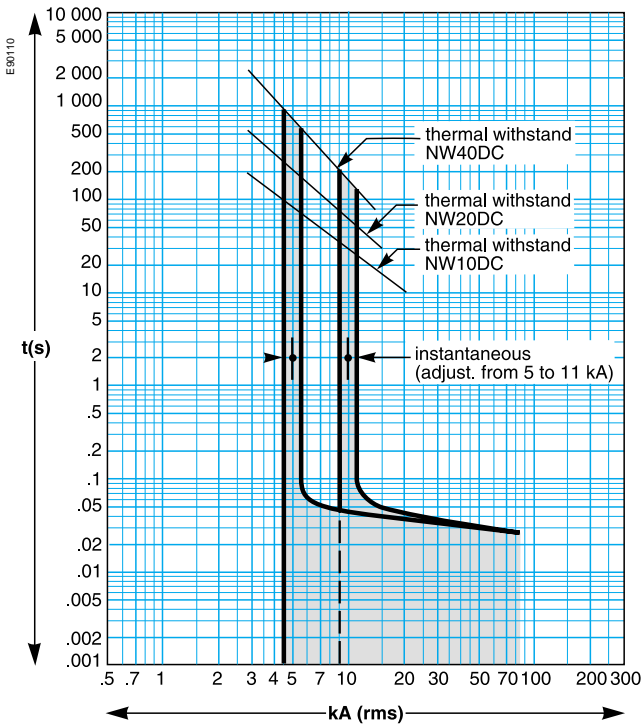

Micrologic DC 1.0 instantaneous protection

With 1250 - 2500 A sensors

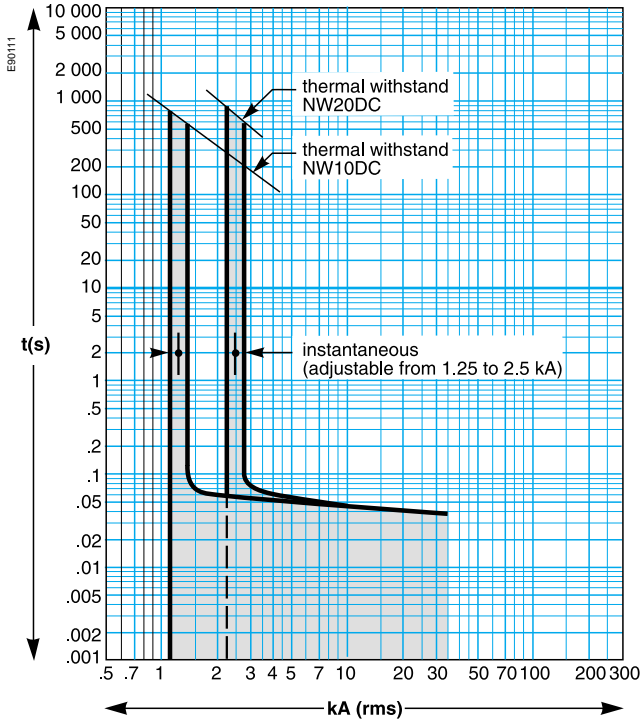

With 2500 - 5400 A sensors

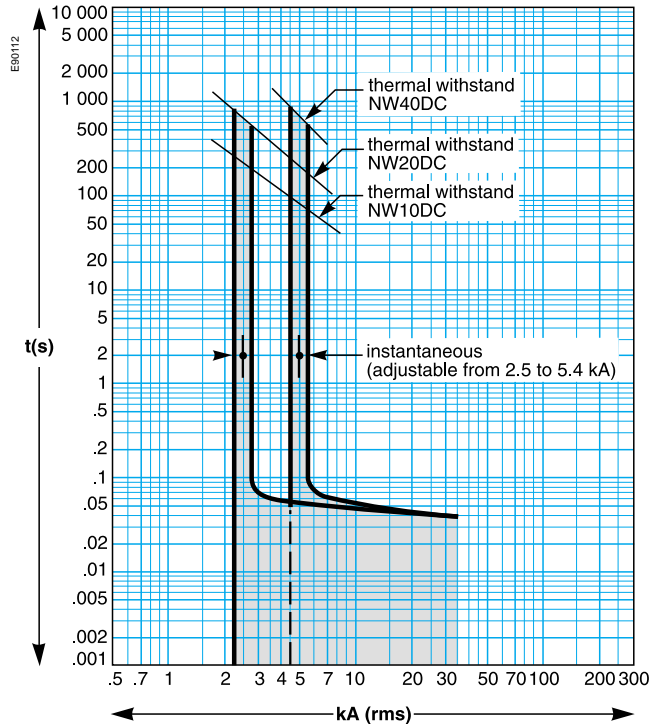

With 5000 - 11000 A sensors

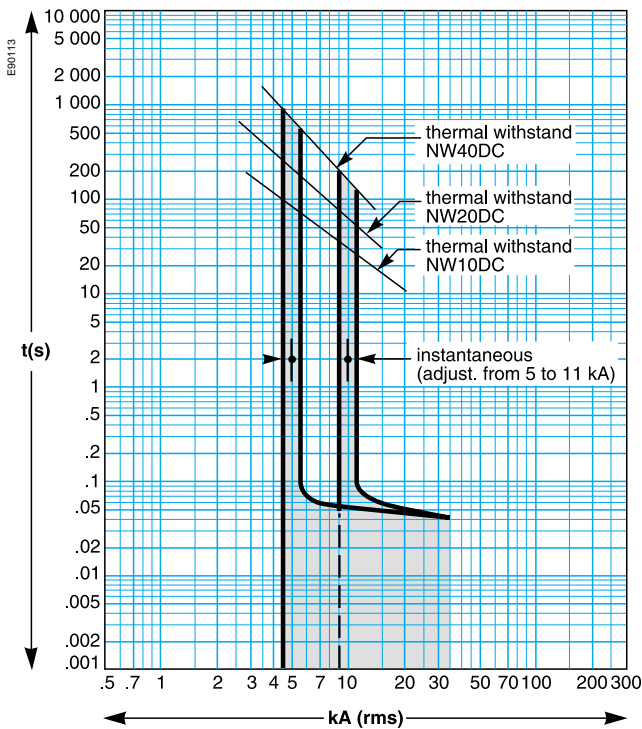

<i>Presentation</i>	2
<i>Functions and characteristics</i>	5
<i>Dimensions and connection</i>	25
<i>Electrical diagrams</i>	37
<i>Installation recommendations</i>	43
<i>Additional characteristics</i>	55
NW10 to NW40 DC fixed and drawout circuit breakers and switch-disconnectors	60
Device selection	60
NW10 to NW40 DC fixed circuit breakers	61
Indication contacts	61
Remote operation	62
NW10 to NW40 DC drawout circuit breakers	63
Indication contacts	63
Chassis locking and accessories	64
Remote operation	65
Accessories for NW10 to NW40 DC fixed and drawout circuit breakers	66
Communication bus accessories and display modules	67
Order form	68

NW10 to NW40 DC fixed and drawout circuit breakers and switch-disconnectors

Device selection

A Masterpact DC circuit breaker is described by 2 catalogue numbers corresponding to:

- the basic circuit breaker (fixed or drawout, with chassis)
- a control unit.

A Masterpact switch-disconnector is described by 1 catalogue number corresponding to:

- the basic switch-disconnector (fixed or drawout, with chassis).

Vertical connection is standard however the connectors can be rotated for on-site conversion to horizontal connection (except on the NW40).

A communication option and various auxiliaries and accessories may also be added.

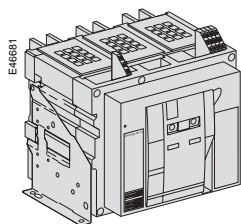

Basic switch-disconnector ≤ 4000 A.

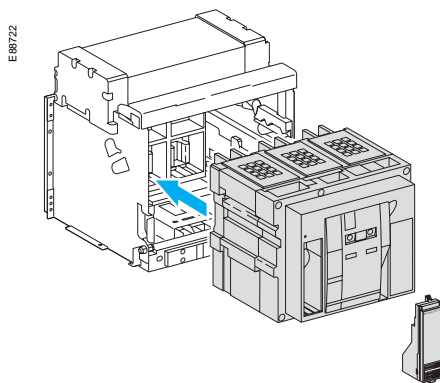

Basic circuit breaker + chassis ≤ 4000 A.

Basic circuit breaker

Type N

	In (A at 40°C)	Icu (kA for U = 500 VDC)	Fixed	Drawout
NW10NDC-C	1000	35	48645	48660
NW20NDC-C	2000	35	48646	48661
NW40NDC-C	4000	35	48647	48662

Type H

	In (A at 40°C)	Icu (kA for U = 500 VDC)	Fixed	Drawout
NW10HDC-C	1000	85	48648	48663
NW10HDC-D	1000	85	48649	48664
NW10HDC-E	1000	85	48650	48665
NW20HDC-C	2000	85	48651	48666
NW20HDC-D	2000	85	48652	48667
NW20HDC-E	2000	85	48653	48668
NW40HDC-C	4000	85	48654	48669
NW40HDC-D	4000	85	48655	48670
NW40HDC-E	4000	85	48656	48671

DC 1.0 Micrologic control unit

Setting range

Minimum (A ± 8 %)	Maximum (E ± 10 %)	
1250	2500	48675
2500	5400	48676
5000	11000	48677

Basic switch-disconnector

Type HA

	In (A at 40°C)	Icm (kA for U = 500 VDC)	Fixed	Drawout
NW10HADC-C	1000	85	48684	48698
NW10HADC-D	1000	85	48685	48699
NW20HADC-C	2000	85	48687	48701
NW20HADC-D	2000	85	48688	48702
NW40HADC-C	4000	85	48690	48704
NW40HADC-D	4000	85	48691	48705

ON/OFF indication contacts (OF)

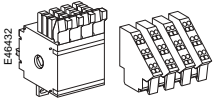

Block of 4 changeover contacts (6 A - 240 V)	1 block (standard)
1 additional block of 4 contacts (2 max.)	48198

"Fault trip" indication contacts (SDE)

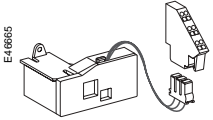

Changeover contact (5 A - 240 V)	1 (standard)
1 additional SDE (5 A - 240 V)	48200
1 additional low-level SDE	48201

Programmable contacts (*) (programmed via Micrologic control unit)

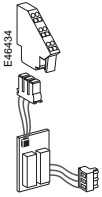

M2C.

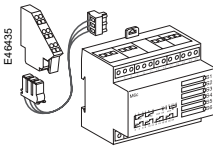

M6C.

2 contacts M2C (5 A - 240 V)	47403
6 changeover contacts M6C (5 A - 240 V)	47404

(*) for Micrologic control units P and H only.

NW10 to NW40 DC fixed circuit breakers (cont.) Remote operation

Remote ON/OFF

Gear motor

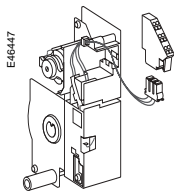

		MCH
AC 50/60 Hz	48 V	48207
	100-130 V	48211
	200-240 V	48212
	250-277 V	48213
	380-415 V	48214
	440-480 V	48215
DC	24-30 V	48206
	48-60 V	48207
	100-130 V	48208
	200-250 V	48209

Instantaneous voltage releases

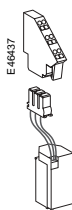

		Closing release	Opening release
Standard		XF	MX
AC 50/60 Hz	12 V DC	47349	47359
	DC		
DC	24-30 V DC, 24 V AC	47350	47360
	48/60 V DC, 48 V AC	47351	47361
	100-130 V	47352	47362
	200-250 V	47353	47363
	277 V AC	47354	47364
	380-480 V AC	47355	47365
	Communicating		XF com
AC 50/60 Hz	12 V DC	47310	47320
	DC		
DC	24-30 V DC, 24 V AC	47311	47321
	48-60 V DC, 48 V AC	47312	47322
	100-130 V	47313	47323
	200-250 V	47314	47324
	277 V AC	47315	47325
	380-480 V AC	47316	47326

"Ready to close" contact (1 max.)

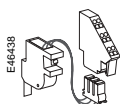

		PF
1 changeover contact (5 A - 240 V)		47342
	1 low-level changeover contact	47343

Electrical closing pushbutton

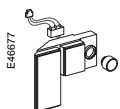

		BPFE
1 pushbutton		48534

Remote reset after fault trip

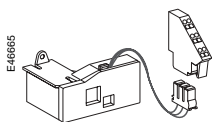

		Res
110-130 V AC		48202
	220-240 V AC	48203
Automatic reset		RAR
Adaptation		47346 (*)

Remote tripping

Instantaneous voltage release

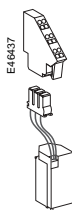

		2 nd MX	or	MN
AC 50/60 Hz	12 V DC	47369		
	DC			
DC	24-30 V DC, 24 V AC	47370		47380
	48-60 V DC, 48 V AC	47371		47381
	100-130 V	47372		47382
	200-250 V	47373		47383
	277 V AC	47374		
	380-480 V AC	47375		47385

MN delay unit

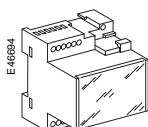

		R (non-adjustable)	Rr (adjustable)
AC 50/60 Hz	48-60 V		33680
	DC		
DC	100-130 V	33684	33681
	200-250 V	33685	33682
	380-480 V		33683

(*) no charge.

NW10 to NW40 DC drawout circuit breakers Indication contacts

ON/OFF indication contacts (OF)

E-48689

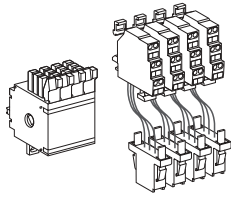

Block of 4 changeover contacts (6 A - 240 V)	1 block (standard)
1 additional block of 4 contacts (2 max.)	48468

Combined closed / connected contacts for use with 1 auxiliary contact

E-48690

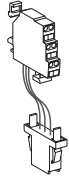

1 contact (5 A - 240 V) (8 max.)	48477
or 1 low-level contact (8 max.)	48478

"Fault trip" indication contacts (SDE)

E-48691

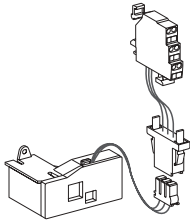

Changeover contact (5 A - 240 V)	1 (standard)
1 additional SDE (5 A - 240 V)	48475
or 1 additional low-level SDE	48476

Carriage switches (connected / disconnected / test position)

E-48681



Changeover contacts (8 A - 240V)	
1 connected position contact (3 max.)	33751
1 test position contact (3 max.)	33752
1 disconnected position contact (3 max.)	33753
and/or low-level changeover contacts	
1 connected position contact (3 max.)	33754
1 test position contact (3 max.)	33755
1 disconnected position contact (3 max.)	33756
Actuator for additional carriage switches	48560

Chassis locking

"Disconnected" position locking

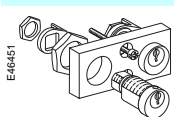

By padlocks		
		Standard
By keylocks		
Profalux	1 lock	48568
	1 lock + 1 lock with same key profile	48569
	2 locks (different key profiles)	48570
Ronis	1 lock	48572
	1 lock + 1 lock with same key profile	48573
	2 locks (different key profiles)	48574
Optional disconnected/test/connected position locking		33779 (*)
Locking kit without locks for		
	Profalux, Ronis	48564
	Kirk	48565
	Castell	48566

Door interlock (1 part)

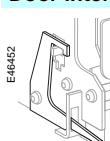

Right-hand side of chassis	48579
Left-hand side of chassis	48580

Racking interlock



1 part	48582
--------	-------

Racking interlock between crank and OFF pushbutton

1 part	48585
--------	-------

Automatic spring discharge before breaker removal

1 part	48554
--------	-------

Breaker mismatch protection



Breaker mismatch protection VDC	33767
---------------------------------	-------

Chassis accessories

Arc chute cover



3P/4P	Standard
-------	----------

Auxiliary terminal shield (CB)



1000/4000 A	3P	48595
	4P	48596

Safety shutters + locking block

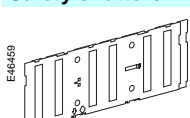

1000/4000 A	3P	48587
	4P	48589

Shutter locking block (for replacement)



2 parts for 1000/4000 A	48591
-------------------------	-------

Front face shutter position indication and locking

1000/4000 A	3P/4P	48592
-------------	-------	-------

(*) no charge.

Remote ON/OFF

Gear motor

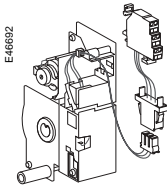

		MCH
AC 50/60 Hz	48 V	48522
	100-130 V	48526
	200-240 V	48527
	250-277 V	48528
	380-415 V	48529
	440-480 V	48530
DC	24-30 V	48521
	48-60 V	48522
	100-130 V	48523
	200-250 V	48524

Instantaneous voltage releases

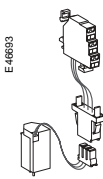

		Closing release	Opening release
Standard		XF	MX
AC 50/60 Hz	12 V DC	48480	48490
	24-30 V DC, 24 V AC	48481	48491
	48-60 V DC, 48 V AC	48482	48492
	100-130 V	48483	48493
	200-250 V	48484	48494
	277 V AC	48485	48495
	380-480 V AC	48486	48496
Communicating		XF com	MX com
AC 50/60 Hz	12 V DC	48448	48457
	24-30 V DC, 24 V AC	48449	48458
	48-60 V DC, 48 V AC	48450	48459
	100-130 V	48451	48460
	200-250 V	48452	48461
	277 V AC	48453	48462
DC	380-480 V AC	48454	48463

"Ready to close" contact (1 max.)

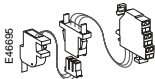

		PF
AC 50/60 Hz	1 changeover contact (5 A - 240 V)	48469
	1 low-level changeover contact	48470

Electrical closing pushbutton

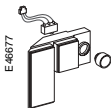

		BPFE
AC 50/60 Hz	1 pushbutton	48534

Remote reset after fault trip

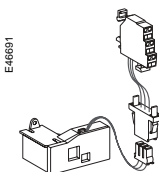

		Res	
AC 50/60 Hz	110-130 V AC	48472	
	220-240 V AC	48473	
Automatic reset		RAR	
DC	Adaptation	47346	(*)

Remote tripping

Instantaneous voltage release

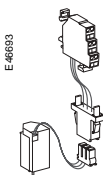

		2 nd MX	or	MN
AC 50/60 Hz	12 V DC	48510		
	24-30 V DC, 24 V AC	48511		48501
DC	48-60 V DC, 48 V AC	48512		48502
	100-130 V	48513		48503
	200-250 V	48514		48504
	277 V AC	48515		
	380-480 V AC	48516		48506

MN delay unit

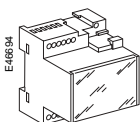

		R (non-adjustable)	Rr (adjustable)
AC 50/60 Hz	48-60 V		33680
	100-130 V	33684	33681
DC	200-250 V	33685	33682
	380-480 V		33683

(*) no charge.

Circuit breaker locking

Pushbutton locking device

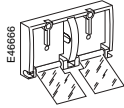

By padlocks	48536
-------------	-------

OFF position locking

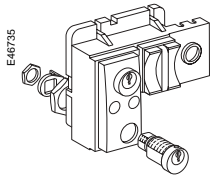

By padlocks		48539
By padlocks and keylocks		
Profalux	1 lock	48545
	1 lock + 1 lock with same key profile	48546
	2 locks (different key profiles)	48547
Ronis	1 lock	48549
	1 lock + 1 lock with same key profile	48550
	2 locks (different key profiles)	48551
Locking kit without locks for	Profalux, Ronis	48541
	Kirk	48542
	Castell	48543

Other circuit breaker accessories

Mechanical operation counter

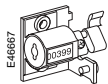

operation counter CDM	48535
-----------------------	-------

Escutcheon and accessories

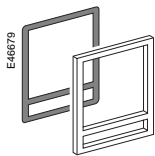

Escutcheon.



Cover.

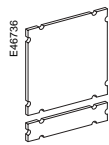

Blanking plate.

	Fixed	Drawout
Escutcheon	48601	48603
Transparent cover IP 54		48604
Escutcheon blanking plate	48605	48605

RS485 Modbus pre-wired system

RS485 Modbus junction block

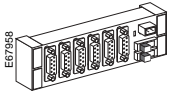

CJB306: 6 SubD 9 pins connectors junction block **50963**

RS485 Modbus connector

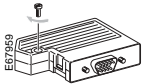

CSD309: 9 pins SubD with screw terminals **50964**

RS485 Modbus cables

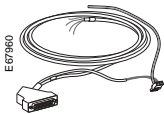

CDM303: display module pre-wired cable, 3 m length **50960**

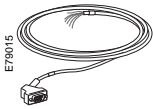

CCP303: Masterpact or Compact pre-wired cable (4 RS485 wires + 2 power wires) 3 m length **50961**



CCR301: RS485 roll cable (2 RS485 wires + 2 power wires) 60 m length **50965**

Digipact Bus pre-wired system

Data concentrator DC150

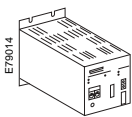

Auxiliary supply voltage 110-240 V AC, 50/60 Hz and 115-125 V DC **50823**

Junction block

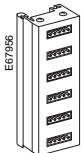

Junction block for internal Bus **50778**

Cables



Cable for internal bus	20-meter roll (0.75 mm ²)	50779
	100-meter roll (0.75 mm ²)	50780

Converter

RS485/RS232 (ACE909) 12 V DC power supply included	59648
RS485/RS232	TSX SCA72 (1)
RS485/Ethernet	174 CEV 300-10 (1)
RS485/Ethernet (SMS compatible)	EGX 200/400 (2)

(1) see catalogue Telemecanique.

(2) see catalogue PowerLogic System.

To indicate your choices, check the applicable square boxes and enter the appropriate information in the rectangles

Basic device		Quantity	<input type="checkbox"/>
Frame size	NW10	<input type="text"/>	
	NW20	<input type="text"/>	
	NW40	<input type="text"/>	
Circuit breaker	N, H	<input type="text"/>	
Switch-disconnector	HA	<input type="text"/>	
Version	C, D, E	<input type="text"/>	
Type of device	Fixed	<input type="text"/>	
	Drawout with chassis	<input type="text"/>	
	Chassis alone	<input type="text"/>	
	Drawout without chassis	<input type="text"/>	

Communication		Quantity	<input type="checkbox"/>
COM	Digipact	<input type="text"/>	
	Modbus	<input type="text"/>	
Eco COM	Modbus	<input type="text"/>	

Connection		Quantity	<input type="checkbox"/>
Horizontal	Top	<input type="text"/>	
	Bottom	<input type="text"/>	
Vertical	Top	<input type="text"/>	
	Bottom	<input type="text"/>	
Interphase barriers		<input type="text"/>	
VO - safety shutters on chassis		<input type="text"/>	
VIVC - shutter position indication and locking		<input type="text"/>	

Locking

VBP - ON/OFF pushbutton locking		<input type="checkbox"/>	
OFF position locking			
VCPO - by padlocks			
VSPO - by keylocks	Locking kit without keylocks	<input type="checkbox"/>	Profalux <input type="checkbox"/> Ronis <input type="checkbox"/>
	1 lock	<input type="text"/>	1 lock + 1 lock with same key profile <input type="text"/>
	2 locks (different key profiles)		<input type="text"/>
VSPD - chassis locking in "disconnected" position			
	Locking kit without keylocks	<input type="checkbox"/>	Profalux <input type="checkbox"/> Ronis <input type="checkbox"/>
	1 lock	<input type="text"/>	1 lock + 1 lock with same key profile <input type="text"/>
	2 locks (different key profiles)		<input type="text"/>
	Optional connected - disconnected - test position locking		
VPEC - door interlock			
	Latch on right-hand side of chassis		
	Latch on left-hand side of chassis		
VPOC - racking interlock			
IPA - cable-type door interlock			
IBPO - racking interlock between crank and OFF pushbutton			
DAE - automatic spring discharge before breaker removal			
VDC - mismatch protection			

Indication contacts

OF - ON/OFF indication contacts			
Standard	410 A - 240 V AC and low-level		
Additional	1 block of 4 OF	Max. 2	qty <input type="text"/>
EF - combined "connected/closed" contacts			
	1 EF 5 A - 240 V AC	Max. 8	qty <input type="text"/>
	1 EF low-level	Max. 8	qty <input type="text"/>
SDE - "fault-trip" indication contacts			
Standard	1 SDE 5 A - 240 V AC		
Additional	1 SDE 5 A - 240 V AC	<input type="text"/>	
	1 SDE low-level	<input type="text"/>	
Carriage switches			
	low-level	<input type="text"/>	
	6 A - 240 V AC	<input type="text"/>	
CE - "connected" position		Max. 3	qty <input type="text"/>
CD - "disconnected" position		Max. 3	qty <input type="text"/>
CT - "test" position		Max. 3	qty <input type="text"/>
AC - actuator for additional carriage switches			qty <input type="text"/>

Remote operation

Remote ON/OFF	MCH - gear motor	V	<input type="text"/>
	XF - closing voltage release	V	<input type="text"/>
	MX - opening voltage release	V	<input type="text"/>
	PF - "ready to close" contact	low-level	<input type="text"/>
		6 A - 240 V AC	<input type="text"/>
			<input type="text"/>
	BPFE - electrical closing pushbutton	<input type="text"/>	
	Res - electrical reset option	<input type="text"/>	
	RAR - automatic reset option	<input type="text"/>	
Remote tripping	MN - undervoltage release	V	<input type="text"/>
	R - delay unit (non-adjustable)	<input type="text"/>	
	Rr - adjustable delay unit	<input type="text"/>	
	2 nd MX - shunt release	V	<input type="text"/>

Accessories

CDM - mechanical operation counter	<input type="text"/>
CB - auxiliary terminal shield for chassis	<input type="text"/>
CDP - escutcheon	<input type="text"/>
CP - transparent cover	<input type="text"/>
OP - blanking plate	<input type="text"/>