

4 - Connection interfaces Telefast® 2 pre-wired system

Presentation and compatibility

<i>Selection guide</i>	<i>page 4/2</i>
■ Passive connection sub-bases	<i>page 4/10</i>
■ Electromechanical relay output sub-bases	<i>page 4/11</i>
■ Solid state input or output sub-bases	<i>page 4/12</i>
■ Analogue sub-bases and special functions	<i>page 4/12</i>
■ Accessories for connection sub-bases	<i>page 4/13</i>
■ Connection cables, I/O modules and interface sub-bases for:	
□ Micro PLCs	<i>page 4/14</i>
□ TSX Premium PLCs	<i>page 4/16</i>
□ Telemecanique TSX 47 to 107 PLCs	<i>page 4/18</i>
□ April Series 1000 PLCs	<i>page 4/19</i>
□ Modicon PLCs and NUM numerical control	<i>page 4/20</i>
□ Allen Bradley SLC500 PLCs	<i>page 4/22</i>
□ Siemens S5 PLCs	<i>page 4/22</i>
□ Siemens S7 PLCs	<i>page 4/24</i>

Characteristics

■ Passive connection sub-bases	<i>page 4/27</i>
■ Removable relay sub-bases, equipped or non equipped	<i>page 4/27</i>
■ Solid state input sub-bases, soldered	<i>page 4/28</i>
■ Removable input relays	<i>page 4/28</i>
■ Solid state output sub-bases, soldered	<i>page 4/29</i>
■ Removable solid state output relays	<i>page 4/29</i>
■ Electromechanical output relay sub-bases, soldered	<i>page 4/30</i>
■ Removable electromechanical output relays	<i>page 4/30</i>
■ Analogue sub-bases and special functions	<i>page 4/31</i>

References

■ Passive connection sub-bases	<i>page 4/36</i>
■ Connection sub-bases with soldered relays and plug-in terminal blocks	<i>page 4/38</i>
■ Plug-in relay sub-bases and plug-in relays	<i>page 4/39</i>
■ Connection sub-bases for counter and analogue channels	<i>page 4/42</i>
■ Terminal blocks, cabled connectors and connection cables for:	
□ Modicon TSX Micro and Premium PLCs	<i>page 4/44</i>
□ TSX 47 to 107 PLCs	<i>page 4/45</i>
□ NUM numerical control	<i>page 4/46</i>
□ APRIL Series 1000 PLCs	<i>page 4/47</i>
□ Modicon 984-A120-Compact PLCs	<i>page 4/48</i>
□ Modicon Quantum PLCs	<i>page 4/49</i>
□ Allen Bradley PLCs	<i>page 4/50</i>
□ Siemens PLCs	<i>page 4/51</i>

Connection interfaces

Telefast® 2 pre-wired system

Discrete input and/or output sub-bases

Applications **Discrete input or output**



4

Relay amplification	-			
Equipped with relay	-			
Control voltage	= 24 V			
Output voltage	= 24 V			
Output current per channel	0.5 A			
Modularity	16	8 -12 -16		
No. of terminals per channel	1	1 to 3	1	2
Type of connection terminals	Signal	Signal, common (configurable = 24 V or 0 V)	Signal	Signal, Common (configurable = 24 V or 0 V)
Connectors	20-way HE10 connector			
Terminal block	Removable		No	
	Type of terminals		Screw	
Additional or optional* function	Low cost version fitted with cable	Miniature sub-bases	Compact size *	Type 2 input * (1)
	Isolator *			
Device type	ABE-7H20E●●● 7H32E●●●	ABE-7H16C●●	ABE-7H●●R1● 7H●●R50	ABE-7H●●R2● ABE-7H●●S21
Pages	4/36		4/37	

(1) For TSX Micro and TSX Premium PLCs.

Discrete Input and output



-		Removable electromechanical or solid state	
-		No	Yes
--- 24 V			
--- 24 V		--- 24 V (solid state) --- 5... 24 V, ~ 230 V (electromechanical)	
0.5 A	0.5 A	5 A (E.M.), 2 A (solid state)	5 A (th)
16		16 8 passive inputs 8 relay outputs	
1	2	1	
Signal, 2 common connections between the inputs and the outputs.	Signal, common, 2 common connections between the inputs and the outputs.	1 N/O contact and common, 4 output channels 2 input connection points	
20-way HE10 connectors			
No			
Screw			
Miniature sub-base Synergy with Tego Power and API Micro PLC		Miniature sub-base - Common per 4 channels Synergy with Tego Power and API Micro PLC	
ABE-7H16CM11	ABE-7H16CM21	ABE-7P16M111	ABE-7R16M111
4/36		4/40	4/39

4

Connection interfaces

Telefast® 2 pre-wired system

Discrete input and output sub-bases

Applications **Discrete output**



4

Relay amplification	Electromechanical, fixed		Electromechanical or solid state			
Equipped with relay	Yes		Yes	No	No	
Control voltage	≡ 24 V					
Output voltage	≡ 5 V... 30 V ~ 230 V	≡ 5 V... 150 V ~ 230 V	≡ 24 V (solid state) ≡ 5 V... 24 V, ~ 230 V (E.M.)	≡ 5 V... 150 V ~ 230 V		
Output current per channel	2 A (th)	3 A (th)	5 A (th)	2 A (solid state), 6 A (electromechanical)	Depends on relay mounted 0.5 to 10 A	
Modularity	8	8 - 16	16	8 or 16		
No. of terminals per channel	2	1	2	1	2 to 3	
Type of connection terminals	1 N/O contact and common Volt-free	1 N/O contact	1 N/O contact and common	1 N/O contact	Signal, Polarities	
Connectors	20-way HE 10 connector					
Terminal block						
Removable	Yes	Yes	Yes	No	No	
Type of terminals	Screw or spring			Screw	Screw or spring	
Additional or optional* function	Miniature sub-base Bistable relay	Volt-free or common per 8 channels		Miniature sub-bases Common per 4 channels	Isolator and fuse	
Device type	ABE- 7R08S216●	ABE- 7R●S1●●	ABE- 7R●S2●●	ABE- 7R16T111	ABE- 7P16T111	ABE- 7P16T2●●● 7P08T3●●●
Pages	4/38		4/39	4/40		

(1) For TSX Micro and TSX Premium PLCs.

Discrete Input

817439



Electromechanical, removable	Solid state, fixed	–	–	Solid state, fixed	Solid state, removable
------------------------------	--------------------	---	---	--------------------	------------------------

Yes	Yes	–	–	Yes	No
-----	-----	---	---	-----	----

From \sim 24 V to \sim 230 V From 5 V TTL to \sim 230 V

\sim 5 V... 150 V \sim 230 V	\sim 24 V				
-------------------------------------	-------------	--	--	--	--

5A (th)	8 A (th)	from 0.5 to 2 A	125 mA	0.5 A	125 mA	12 mA
---------	----------	-----------------	--------	-------	--------	-------

16

2 to 3	2 to 6	2	3	2
--------	--------	---	---	---

1 C/O contact or 1 N/O contact and common	1 C/O contact or 2 C/O contacts and common	Signal and 0 V	Signal \sim 24 V and 0 V	Signal can be isolated, Protected common	Signal	Signal and common
---	--	----------------	----------------------------	--	--------	-------------------

No	Yes	No	No	Yes	No
----	-----	----	----	-----	----

Screw	Screw or spring		Screw	Screw or spring	
-------	-----------------	--	-------	-----------------	--

Volt-free or common per: 8 channels	4 channels	Fault signal	Isolator and fuse (indicator)	3-wire proximity sensor	Isolator and fuse (indicator)	–
--	------------	--------------	-------------------------------	-------------------------	-------------------------------	---

ABE-7R16T2●●	ABE-7R16T3●●	ABE-7S●●S2B●	ABE-7H16F43	ABE-7H16R3●	ABE-7H16S43	ABE-7S16E2●●	ABE-7P16F31●
---------------------	---------------------	---------------------	--------------------	--------------------	--------------------	---------------------	---------------------

4/39	4/38	4/37	4/38	4/41
------	------	------	------	------

4

Applications Analogue signals and special functions



4

Compatibility	TSX Micro	TSX Premium	Standard	
Type of signal	Counter inputs and analogue I/O	Counter inputs Axis control Position control	Analogue inputs Current Voltage Pt 100	Analogue outputs Current Voltage
Functions	Passive connection, point-to-point with shield continuity			
Modularity	1 counter channel or 8 analogue inputs + 2 analogue outputs	8 channels	4 channels	
Control voltage	--- 24 V			
Output voltage	--- 24 V			
Output current per channel	25 mA			
Number of terminals per channel	2	2 or 4	2 or 4	
Type of connector	15-way SUB-D + 9-way SUB-D		25-way SUB-D	
Terminal block	Removable		No	
	Type of terminals		Screw	
Device type	ABE-7CPA01	ABE-7CPA02	ABE-7CPA21	
Pages	4/42			

817435



817434



	TSX Premium TSX AEY810	TSX Premium TSX CAY01 TSX CTY2C	TSX Premium TSX AEY1614	TSX Premium TSX PAY202
Analogue inputs Current Voltage Pt 100	Isolated analogue inputs	Inputs Counter	Inputs for thermocouples	I/O
Distribution of sensor power supplies per limiter (25 mA)	Distribution of isolated sensor power supplies per converter	Acquisition of value from an absolute encoder	Connection of 16 thermocouples with cold junction compensation	Safety module (BG)
8 channels	8 channels	1 channel	16 channels	12 Emergency stops
				-
		-	2 or 4	1
25-way SUB-D	25-way SUB-D	15-way SUB-D	25-way SUB-D	50-way SUB-D
No	No	No	No	No
Screw	Screw or spring	Screw	Screw	Screw
ABE-7CPA03	ABE-7CPA31	ABE-7CPA11	ABE-7CPA12	ABE-7CPA13

4

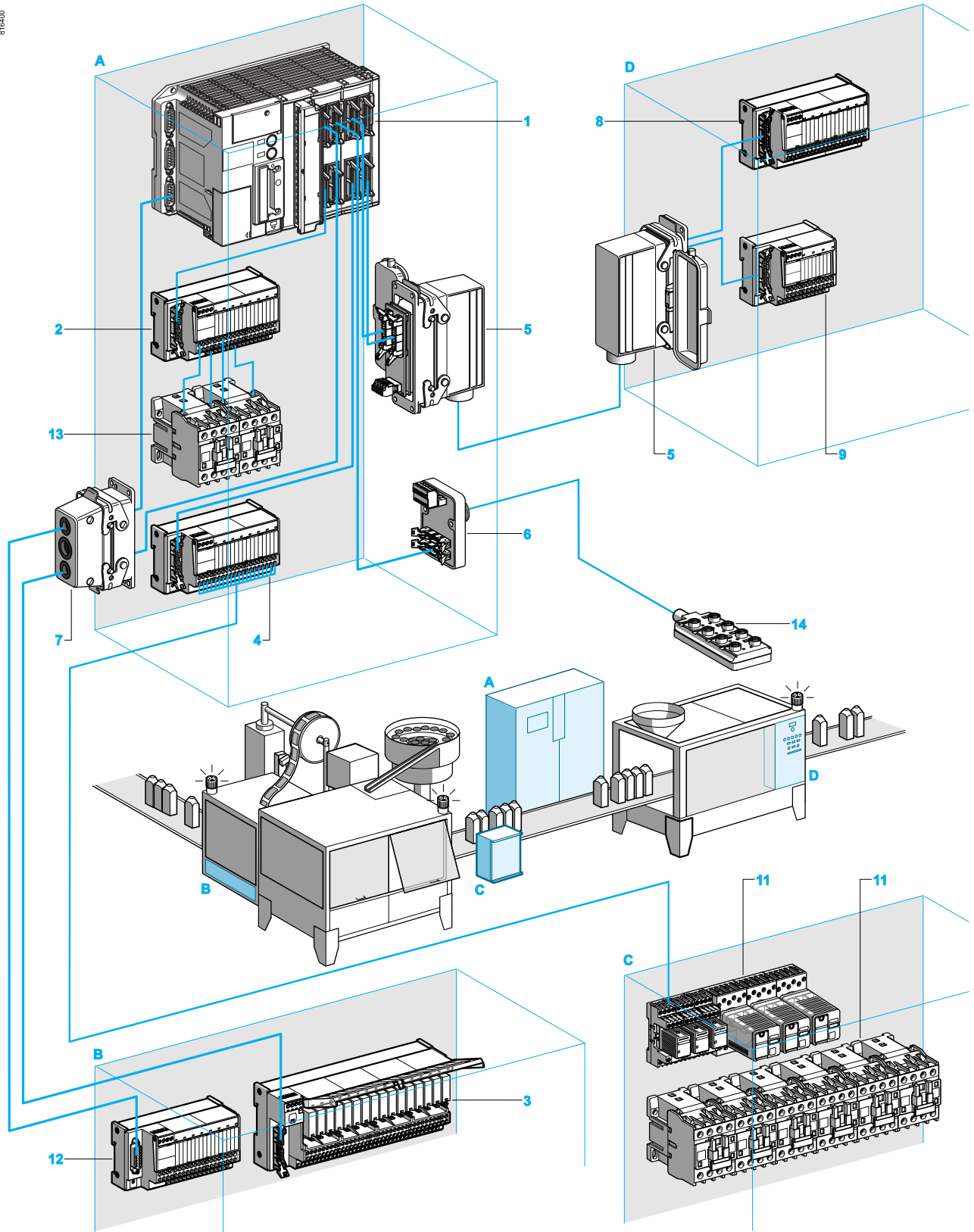

General presentation

The Telefast 2 system is a set of products for rapid connection of I/O modules (≡ 24 V discrete, analogue and counter) to operative parts. It acts as a substitute for screw terminal blocks, remotely locating and partly eliminating the single-wire connection.

The Telefast 2 system only connects to channels which have HE 10 and SUB-D connectors or to standard terminal blocks with a cabled connector. It consists of connecting cables and interface sub-bases.

The relay and connection functions, with or without polarity distribution, considerably reduce wiring time and eliminate the risk of error.

Connections between the PLC and the operative part

Connection between the PLC and Telefast 2 sub-bases

Telefast 2 sub-bases connect directly via cables onto all discrete I/O modules fitted with HE 10 connectors **1**.

I/O modules not fitted with HE 10 connectors are connected to Telefast 2 sub-bases by means of cabled connectors. These consist of a cable whose conductors (0.34 mm c.s.a.) are connected to the standard terminal block at one end and to the HE 10 connectors at the other. They are available in 1.5 and 3-metre lengths.

Connection between Telefast 2 sub-bases and the operative part

The Telefast 2 range is suitable for all types of connection found in control system devices.

Connection of I/O located in the PLC cabinet **A** or nearby **B**.

Some sub-bases **2** enable two wires (signal and common) or 3 wires (signal, 24 V, 0 V) to be connected directly from sensors or preactuators when the latter **13** are installed in the same enclosure or very close by. They effectively eliminate all intermediate terminal blocks.

Other versions offer the possibility of adapting the voltage or current via removable relay sub-bases **3** or of connecting analogue signals **12**.

In cases where size is of prime importance **D**, fixed relay sub-bases ABE-7R1 6S111 **8** (125 mm long) and passive sub-bases ABE-7H16R50 **9** (84 mm long) reduce the required surface area by about 50 % compared with standard products.

Connection of I/O located outside the PLC cabinet **C**.

These sub-bases **4** which connect connector leads from sensors or preactuators **11** fulfil the same function as traditional terminal blocks.

IP65 dust and damp-proof connections for enclosures and cabinets

When the operative part has to be separate from the control part, enclosure feedthroughs are used to join HE 10 connectors and:

- 40-way, rectangular, industrial connectors for 32-channel versions **5**,

- 19-way, cylindrical, CNOMO M23 connectors, for 8, 12 and 16-channel versions **6**. Eight-channel versions offer, in addition, the possibility of directly connecting the XSZ dust and damp-proof splitter blocks **14** for 8 sensors.

In applications where the control cabinet is integral to the operative part, the cable gland assembly **7** enables the direct output of 3 Telefast 2 cables without additional connections.

Description of a Telefast 2 connection sub-base

816401

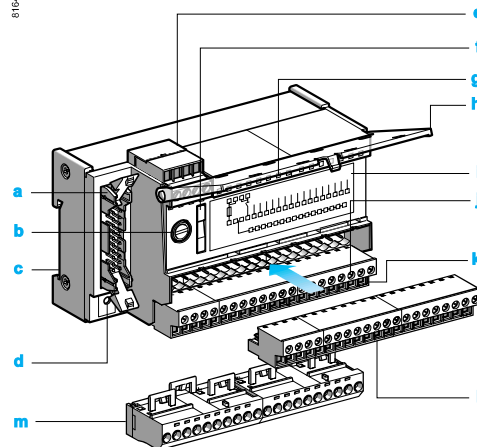

All connection sub-bases in the Telefast 2 family have a standardised design and offer the common functions described below.

Some of these functions are optional*.

- a 20-way HE 10 connector
- b ≡ 24 V power supply circuit fuse
- c Fixing on DIN rail
- d ≡ 24 V display LED
- e ≡ 24V power supply terminal block (1)
- f Blade type isolator on ≡ 0 V
- g Channel indication LED*
- h Customer label-holder/cover
- i Wiring diagram
- j Test point for 0.2.3 mm plug
- k Upper terminal block (1)
- l Lower terminal block (1), offset by 1/2 step*
- m Additional clip-on terminal block fitted with 20 screw or spring terminals*

(1) Removable screw or spring type, according to reference, at 5.08 mm intervals.

Connection interfaces

Telefast® 2 pre-wired system
Passive connection sub-bases

Designed to simplify I/O connection to a PLC within a control panel, the range of passive sub-bases has the same functions as traditional terminal blocks to which they add, depending on the models, compact size, connection of proximity sensor commons (3-wire and type 2), LED indication, protected and isolated channels. For high sales volume products, screw or spring connections are available (references ending with E).

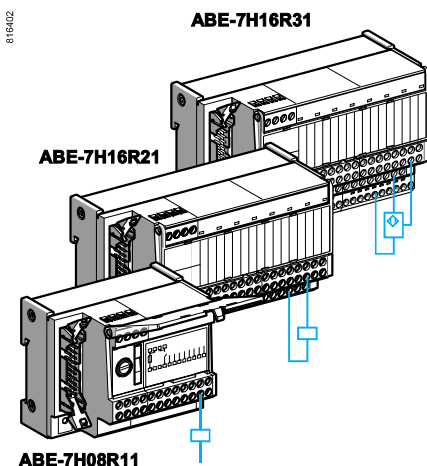

ABE-7H08R11

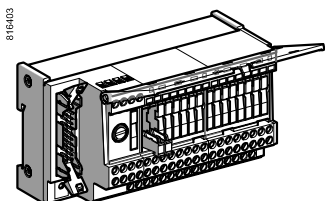

ABE-7H16S21

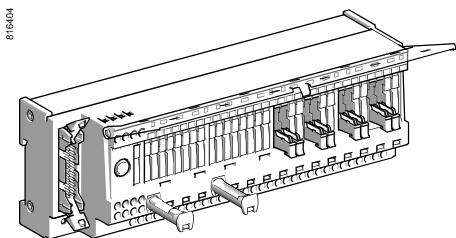

ABE-7H16S43

Terminal block sub-bases

ABE-7H●R11/R10: these products can be used to connect inputs or outputs. The commons are made on the device and brought into the sub-base by a single wire. The output terminals are on a single row.

The signal state for each channel can be indicated via a LED (R11) or not (R10).

A terminal block sub-base ABE-7BV●0 can be added.

ABE-7H20E●●/7H32E●●●: these extremely economical products are supplied with a direct connection cable for ModiconTSX Micro, Premium or other PLCs using splitter sub-base HE20E, or for Siemens S7 PLCs using splitter sub-base H32E. The cable is available in 3 or 2 metre lengths respectively. The output terminals are on 2 rows.

Compact sub-bases

ABE-7H●R50: these products fulfil the same functions as the previous sub-bases but their size is reduced by almost half.

The output terminals are in fact on two rows.

ABE-7H16C1●/CM11: these are miniature products. The signal state for each channel can be indicated via an LED (C11/CM11) or not (C10). The output terminals are on one row. A terminal block sub-base ABE-7BV●0 can be added.

Universal sub-bases

ABE-7H●R21/R20: these sub-bases are used to connect I/O, and all the commons.

The potential (0 V or 24 V), distributed over the row of screw terminals which allow the commons to be connected, is selected via a jumper (see page 4/54). Both wires of the sensor or actuator can be connected to the sub-base. The output terminals are on two rows. The state of the signal for each channel can be indicated via an LED (R21) or not (R20).

ABE-7H16C21/CM2: these are miniature products. The signal state for each channel can be indicated via an LED. Reference CM21 has two commons connections which allow both the inputs and outputs to be connected at the same time, with a 0 or 24 V common, according to the customer's wiring. The output terminals are on 2 rows.

Sub-bases for 2-wire sensors

ABE-7H16R23: this product is identical to the ABE-7H16R21 sub-bases but, in addition, enables connection of 2-wire type 2 sensors on the ModiconTSX Micro and Premium and Num N.C. The output terminals are on two rows.

Sub-bases for 3-wire detectors

ABE-7H16R31/R30: the signals, \pm 24 V and 0 V, are brought into the sub-base for each channel. The output terminals are on three rows. This function can also be achieved by adding an ABE-7BV20 add-on terminal block to the ABE-7H16R21/R20 sub-bases.

The state of the signal for each channel can be indicated via an LED (R31) or not (R30).

ABE-7H16C31: these are miniature products. They also enable connection of inputs equipped with 3-wire proximity sensors. The output terminals are on 3 rows..

Sub-bases with isolator for each channel

ABE-7H●S21: these products have the same function as the ABE-7H16R21 universal sub-base. In addition, they also have, a blade isolator for each channel.

Sub-bases with isolator and protection for each channel

ABE-7H16S43 : these products are used exclusively for connecting \pm 24 V inputs.

Both wires are brought to the screw terminals on a single row.

Each channel has 2 blade isolators, fixed together, to isolate the signal and its \pm 24 V supply. The 24 V supply to each channel is protected by a 5 x 20 fuse. A red LED indicates if the fuse has blown.

ABE-7H16F43: these products are designed for connecting \pm 24 V outputs. Both wires are brought to the screw terminals on a single row.

Each channel has 2 blade isolators, fixed together, to isolate the signal and its 0 V common.

Connection interfaces

Telefast® 2 pre-wired system
Electromechanical relay output sub-bases

Relay output sub-bases are designed to adapt both current and voltage signals. They also have the following functions, depending on the model: various contact combinations (1 N/O, 1 C/O, 2 C/O), common potentials, channel protection by 5 x 20 fuse. There are 3 ranges of sub-bases: fixed relay, removable relay and high-performance. For high sales volume products, screw or spring connections are available (references ending with E).

Sub-bases with fixed relays and removable terminal blocks

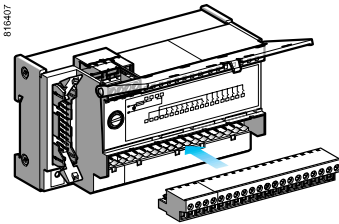

ABE-7R16S111

ABE-7R●●S21●: these products are equipped with a fixed relay, with integral N/O contact, 10 mm wide. Their 5A Ith characteristic must be derated according to the duty cycles used and the number of operations required.

They are available in 8 and 16-channel modules. All the terminal blocks are removable.

ABE-7R●●S11: almost 50% smaller than the standard sub-bases, these products have a fixed relay, integrating an N/O contact, 5 mm wide. Their 2A Ith characteristic must be derated according to the duty cycles used and the number of operations required. They are available in 8 and 16-channel modules. All the terminal blocks are removable.

ABE-7R08S216: these miniature products are equipped with latching relays which can withstand a current of 2A at ~ 230 V. They enable 2 output wires to be connected on a removable terminal block. Two PLC outputs are used per channel: one for tripping the relay, the other for resetting it. The relay stays in the de-energised position. The state of the signal for each channel can be indicated via an LED.

Removable relay sub-bases

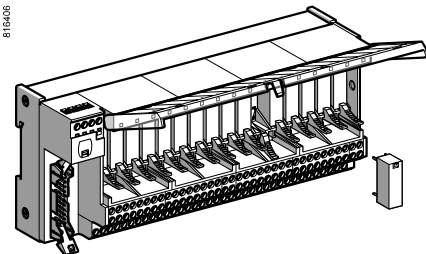

ABE-7R16T2●●

ABE-7P16T2●● and **7R16T2●●**: these products may or may not be equipped with a removable relay, with integral N/O or C/O contact, 10 mm wide. Their 5A Ith characteristic must be derated according to the duty cycles used and the number of operations required. They are available in 16-channel modules only.

ABR-7S2● electromechanical relays, **ABS-7S●2●** solid state relays and **ABE-7ACC20** continuity block can all be combined on the same sub-base. Some sub-bases, not equipped with relays, are offered with 5 x 20 fuse protection for each channel.

ABE-7●16T111/M111: these miniature products use removable relays, 5 mm wide, with integral N/O contact, rated up to 5A. These products may be pre-equipped with relays (R) or not (P). They can be fitted with both electromechanical and solid state relays.

Sub-bases **ABE-7●16M111** offer two connection methods which make it possible to connect both inputs and outputs and obtain 8 inputs (passive connection) and 8 outputs (active relay connection). The state of the signal for each channel can be indicated via a LED. The terminals are on one row and the commons are brought in groups of 4. The sub-base is supplied with a relay extractor; this accessory is also available as a spare part.

High performance sub-bases with removable relays

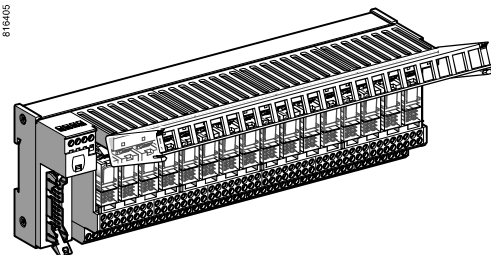

ABE-7R16T3●●

ABE-7P●●T3●● and **7R16T3●●**: these products may or may not be equipped with removable relays, with integral 1 C/O or 2 C/O contacts, 12 mm wide. Their 8A Ith characteristic must be derated according to the duty cycles used and the number of operations required.

The relays are equipped with reinforced Faston type clips for easy attachment.

They are available in 8 and 16-channel modules.

ABR-7S3● electromechanical relays, **ABS-7S●3●** solid state relays and **ABE-7ACC21** continuity block can all be combined on the same sub-base. Some sub-bases, not equipped with relays, are offered with 5 x 20 fuse protection and isolation for each channel.

Connections

These relay sub-bases can be connected according to three possible schemes: volt-free, contact common and common on both poles.

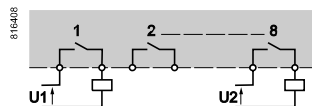

Volt-free

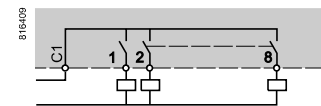

Contact common

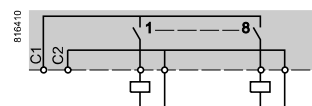

Common of both poles

Connection interfaces

Telefast® 2 pre-wired system
Solid state input or output sub-bases. Analogue sub-bases

Solid state input or output sub-bases

Solid state input or output sub-bases are designed to adapt both current and voltage signals. They can be used to interface either inputs or outputs. Their technology enables high-speed signal switching, while maintaining a high level of electrical durability. For high sales volume products, screw or spring connections are available (references end with E).

Input adaptor sub-bases

Sub-bases equipped with solid state channels ABE-7S16E●●: these sub-bases enable sensors with different voltages to be connected ($\approx 24\text{ V}$ to $\sim 230\text{ V}$ according to the reference).

These products provide electrical isolation for the various power supply inputs. They are available in 16-channel modules only and the terminal blocks are removable.

Sub-bases equipped with removable solid state relays ABE-7P16F●●: these sub-bases enable sensors with different voltages to be connected ($\approx 24\text{ V}$ to $\sim 230\text{ V}$), either on each channel or on each group of 8 channels.

They are available in 16-channel modules only. The solid state relays are available separately. It is also possible to equip the sub-bases with electromechanical relays (please consult your Regional Sales Office).

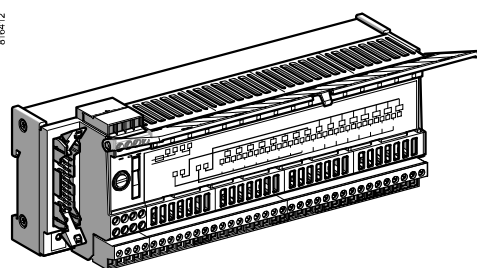

ABE-7S16E2B1

Output adaptor sub-base

Sub-bases equipped with solid state channels ABE-7S●●S●●: these sub-bases enable actuators to be connected at $\approx 24\text{ V}$. The outputs are not isolated. The output current is, depending on the products, 0.5 or 2 A per channel.

The occurrence of overloads or short-circuits on the outputs can be transmitted to the PLC to be managed by program. These "fault report" functions can only be used with Modicon TSX Micro and Premium PLCs or with any other PLCs which have protected outputs.

They are available in 8 and 16-channel modules, and the terminal blocks are removable.

Removable solid state relays

ABS-75 removable relays are not available mounted directly on the sub-bases. They must be ordered separately.

These relays are available for two power levels:

- from $\approx 5\text{ V}$ to $\sim 240\text{ V}/0.5\text{ A}$, 10 mm wide. These are for mounting on ABE-7P16T2●● sub-bases,

- from $\approx 5\text{ V}$ to $\sim 240\text{ V}/1.5$ and 2 A, 2mm wide. These are for mounting on ABE-7P16T3●● or ABE-7P08T330 sub-bases.

It is possible to combine electromechanical relays and solid state relays, as well as continuity blocks, on the same sub-base.

They are available in 16-channel modules only.

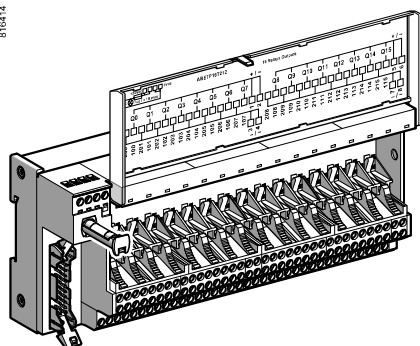

ABE-7P16T212

Analogue sub-bases and special functions

Analogue signals are connected on the following products :

- Sub-base **ABE-7CPA01** for the counter modules in the Modicon TSX Micro and premium range. It also communicates with the Altivar 18 variable speed drives.
- Sub-base **ABE-7CPA02** for connection and distribution of 8 channels over the screw terminals while maintaining shielding continuity.
- Sub-base **ABE-7CPA21** with identical functions to the previous sub-base for the 4 analogue output channels.
- Sub-base **ABE-7CPA03** can also supply 2 or 4-wire sensors, channel by channel, with $\approx 24\text{ V}$ protected voltage and current limiting at 25 mA. In addition, it ensures continuity of the current loops when the 25-way SUB-D connector is unplugged.
- Sub-base **ABE-7CPA31** enables distribution and isolation of the $\approx 24\text{ V}$ power supply required for the 8 analogue input channels while maintaining isolation between channels of the TSX AEY810 module. Limitation for all channels is 25 mA.
- Sub-base **ABE-7CPA11** enables the value from a parallel output absolute encoder to be read (binary or GRAY code). It is connected to a counter or axis control module in the Modicon TSX Premium range.
- Sub-base **ABE-7CPA12** can be used to connect 16 thermocouples and to increase the temperature of the terminal blocks for cold junction compensation, either by a probe integrated in the sub-base, or remotely via an external PT100 probe. In the latter case, only 14 thermocouples can be connected.
- Sub-base **ABE-7CPA13** simplifies connection of safety module TSX PAY2●2 on the Modicon TSX Premium. It allows the connection of 12, double contact emergency stops.

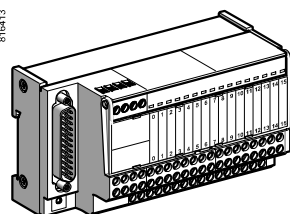

ABE-7CPA02

Connection interfaces

Telefast® 2 pre-wired system
Accessories for connection sub-bases

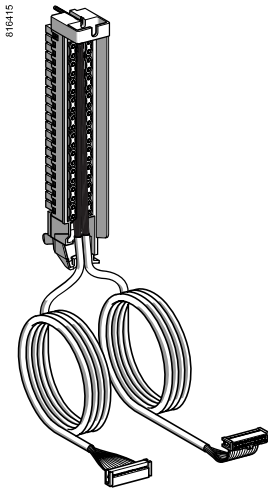

ABF-A32H00

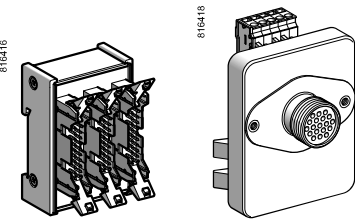

ABE-7ACC02

ABE-7ACC82

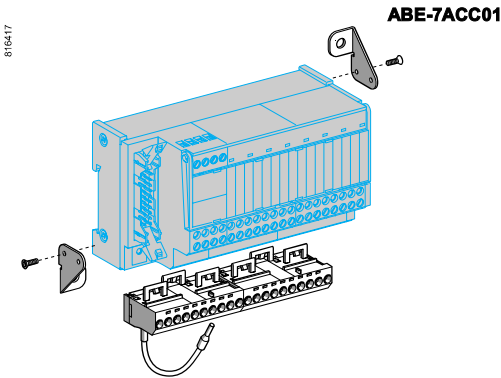

ABE-7BV20

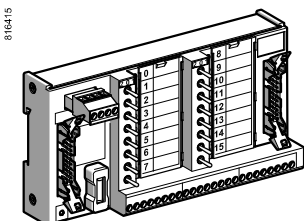

ABE-7TES160

The telefast 2 pre-wired system offers a range of accessories to simplify the installation of equipment and to enable full use of all features offered by the connection sub-bases.

Connection to the PLC: cables and cabled connectors

Cables

Only **ABF-H20H000** cables, made from rolled ribbon cable and HE 10 insulation piercing connectors are truly universal. Owing to their small size, they can be connected to any I/O modules or terminal blocks fitted with 20-way HE 10 connectors. They are available in lengths of 0.5 to 5 m, but the user can create custom cables up to a maximum length of 30 m using additional cable and HE 10 connectors.

TSX-CDP003 moulded cables are only used with the Modicon TSX Micro and Premium ranges. They are multicore cables and have a high quality finish.

Custom cables are also available for the Allen Bradley and Siemens ranges of PLCs.

Cabled connectors

When the PLC I/O modules do not have rapid connection features, the cables and terminal blocks are pre-assembled by us to produce a pre-wired solution. Telefast 2 can therefore offer cabled connectors suitable for the Modicon, April (**ABF-A32H000**) and Telemecanique ranges of analogue modules.

Splitter sub-bases

When module configuration and signal distribution are not compatible, the Telefast 2 system can use **ABE-7ACC00** splitter sub-bases:

- 16 channels (2 x 8) for all 16-channel outputs,
- 24 channels (3 x 8) for DST2472 modules,
- 32 channels (2 x 16) for NUM inputs,
- 24 channels (3 x 8) for NUM outputs.

Other sub-bases enable I/O redundancy on 2 input modules in parallel (**ABE-7ACC11**) or on 2 output modules in parallel (**ABE-7ACC10**).

Wiring accessories

Enclosure feedthroughs

The IP65 **ABE-7ACC80** product range comprises:

- two compact devices, one for 8-12 channel configurations and the other for 16 channel configurations, enabling Telefast 2 sub-bases to be connected to the outside of the enclosure. They provide the connection between HE 10 connectors (inside the enclosure) and the cylindrical CNOMO M23 type connector (outside the enclosure). These products can also be used to connect dust and damp proof splitter blocks with M12 cylindrical connectors for sensors.
- a second device which uses a 40-way rectangular industrial connector to connect 2 x 16 channels.

Cable gland assembly

Using the cable gland assembly enables 3 cables to run outside the enclosure without the addition of a series connection.

ABE-7ACC01 mounting kit for solid mounting plate

This provides an alternative solution for mounting sub-bases without using an additional rail.

Additional terminal blocks ABE-7BV10 and ABE-7BV20

With 8 and 16 channels, these products give wider connection alternatives: common, screening, etc..

Other accessories

Removable continuity blocks

Available in 10 and 12 mm widths, the blocks are mounted on **ABE-7P16T000** relay sub-bases in place of **ABR-7** and **ABS-7** modules. They make use of the sub-base functions to connect the channel without the need to adapt the channel using a relay.

ABE-7TES160 simulation sub-base

Can be used to force or inhibit the discrete I/O.

5 x 20 fuses

References for all fuses can be found under accessories.

Label marking software

This produces finished labels for marking channels, simplifying installation and reducing the risk of error during maintenance by marking the labels according to the sub-base mounting. The program runs under Windows.

Connection interfaces

Telefast® 2 pre-wired system
Connection cables for Micro PLCs

4

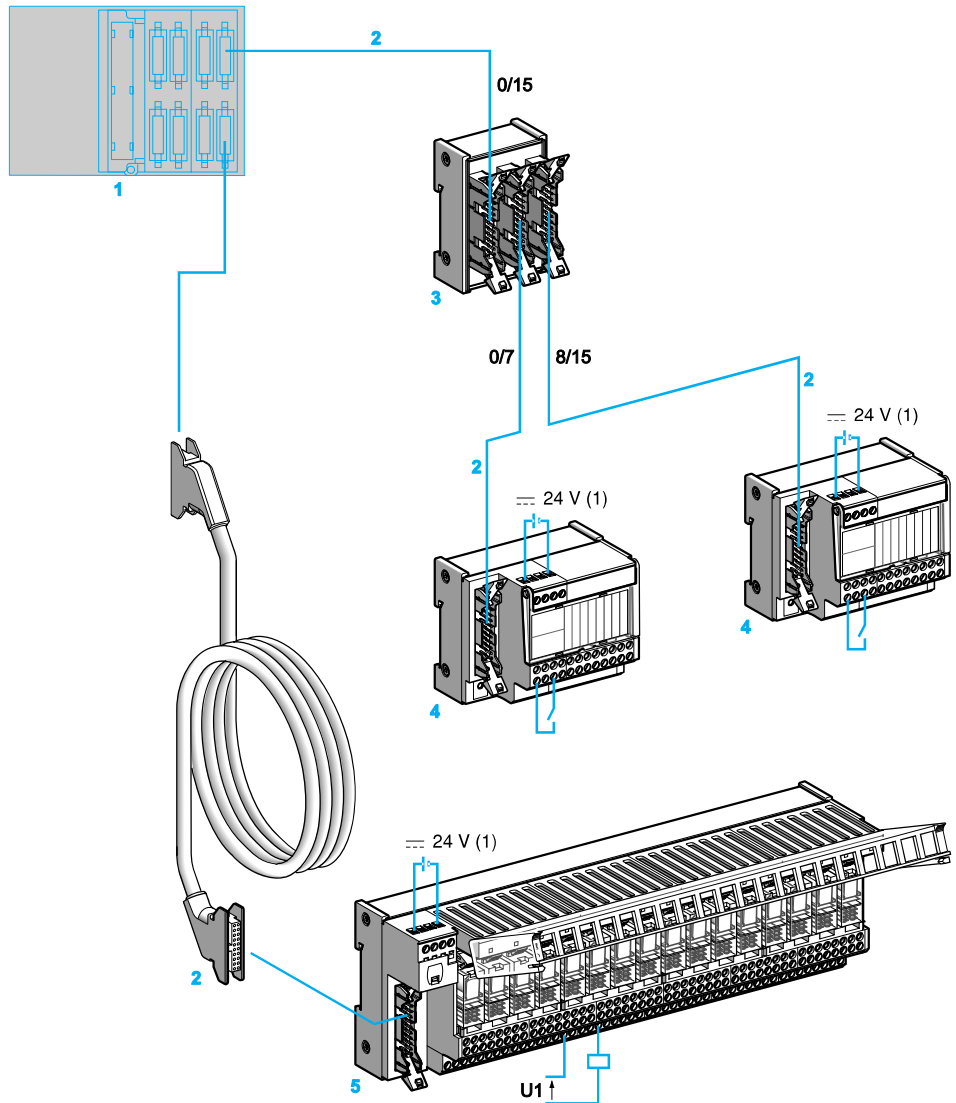

- 1 I/O modules equipped with HE 10 connectors. Available in modules of 8, 12, 28 and 64 I/O.
- 2 A single type of cable equipped with 20-way HE 10 connectors irrespective of the 8, 12 or 16-channel modularity. The HE 10 connectors may be moulded (TSX CDP●●●) or self-perforating (ABF-H20H●●●). These cables are available in 0.5, 1, 2, 3 and 5 metre lengths. They use AWG 28 (0.08 mm²) for connection of inputs and relay sub-bases, and AWG 22 (0.324 mm²) for direct connection of the 8 and 28 I/O module 0.5 A outputs.
- 3 16 channels may be split into 2 x 8 channels using splitter sub-base ABE-7ACC02.
- 4-5 8-channel and 16-channel sub-bases respectively.

(1) The 24 V power supply is connected using Telefast 2 sub-bases only. The 0 V connections must be equipotential.

I/O modules for TSX Micro PLCs

		24 V discrete I/O					Inputs		Outputs		Counter		Analogue and counter
		I/O								Auxiliary inputs	Counter		
		8 I + 8 Q	1 x 16 I	1 x 12 Q	2 x 16 I	2 x 16 Q	1 x 12 I	1 x 8 Q					
Integrated in the PLCs	TSX	–	37 10 128DTK1		37 10 164DTK1		–	–	–	–	–	–	37 22 001
	TSX	–	–	–	–	–	–	–	–	–	–	–	37 22 101
With modules	TSX	DMZ 16DTK	DMZ 28DTK		DMZ 64DTK		DEZ 12D2K	DSZ 08T2K	CTZ 1A	CTZ 1A	–	–	–
	TSX	–	–	–	–	–	–	–	CTZ 2A	CTZ 2A	–	–	–

Connection sub-bases

8 chans.	ABE-7H08R●●		(1)		(1)	(1)			ABE- (2) 7H08R10			
	ABE-7H08S21		(1)		(1)	(1)						
12 chans.	ABE-7H12R●●											
	ABE-7H012S21											
16 chans.	ABE-7H16R●●/H16C●●/H20E●●								ABE- (3) 7H016R20			
	ABE-7H16S21											
	ABE-7H16R23											
	ABE-7H16F43											
	ABE-7H16S43											

Input adaptor sub-bases

16 chans.	ABE-7S16E2●●						(5)					
	ABE-7P16F3●●						(5)					

Input and output adaptor sub-bases

16 chans. 8 I + 8 Q	ABE-7H16CM●1											
	ABE-7●16M111											

Output adaptor sub-bases

8 chans.	ABE-7S08S2●●					(1)						
	ABE-7R08S●●●					(1)						
	ABE-7P08T330					(1)						
16 chans.	ABE-7S16S●●●											
	ABE-7R16S●●●			(4)								
	ABE-7R16T●●●			(4)								
	ABE-7P16T●●●			(4)								

Sub-bases for analogue/counter I/O

ABE-7CPA01												
ABE-7CPA11												
ABE-7CPA02												
ABE-7CPA03												

- (1) Via splitter sub-base ABE-7ACC02, which allows 16 channels to be split into 2 x 8 channels.
- (2) With module TSX CTZ 1A, to be used with sub-bases with no LED.
- (3) With module TSX CTZ 2A, to be used with sub-bases with no LED.
- (4) The last four channels are not used and remain at 1.
- (5) The last four channels are not used.

 Pre-wired cables

Connection interfaces

Telefast® 2 pre-wired system
Connection cables for TSX Premium

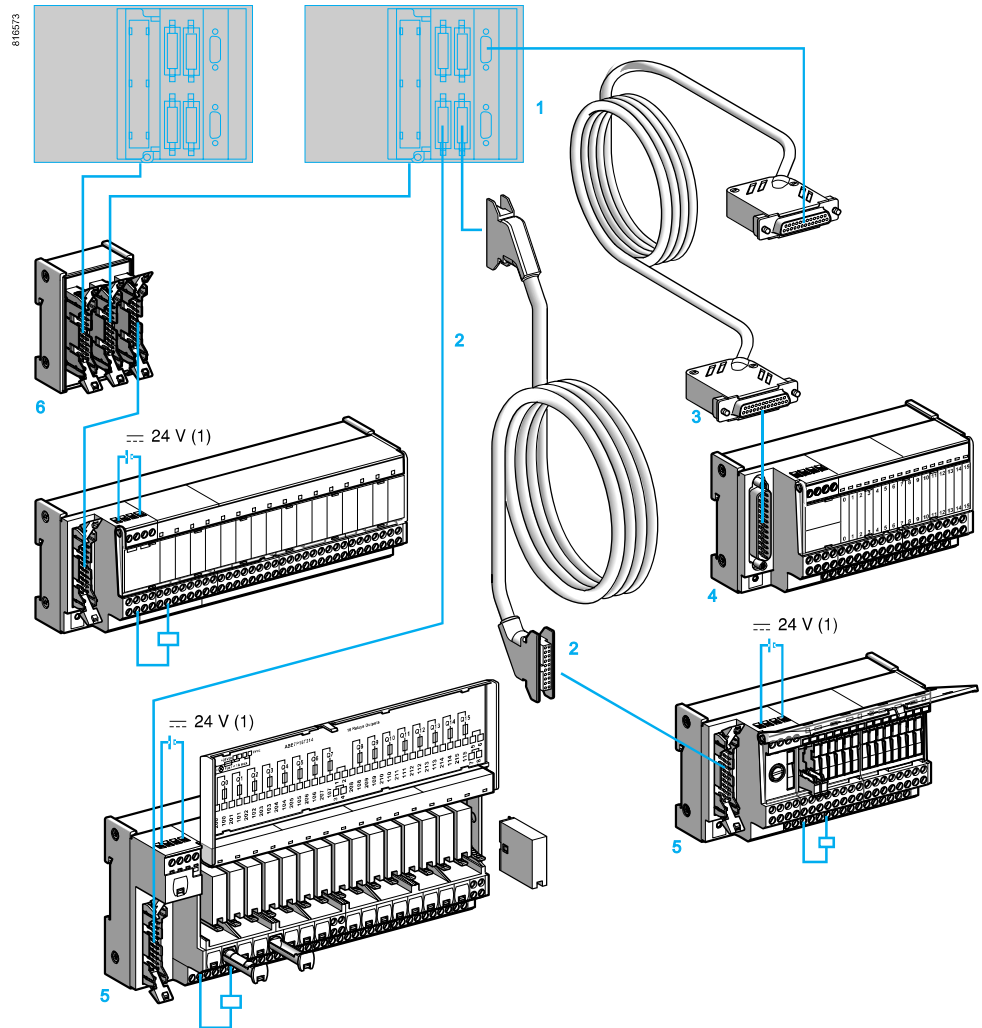

- 1 Input and output modules fitted with HE 10 connectors available for 16, 32 and 64 I/O.
- 2 A single type of cable fitted with 20-way HE 10 connectors, whether the modularity is 8, 12 or 16 channels. The HE 10 connectors can be moulded, TSX CDP●●● (AWG 22) or self-perforating, ABF-H20H●●● (AWG 28). These cables are available in 0.5, 1, 2, 3 and 5 metre lengths (the same as those used with the Modicon TSX Micro). AWG 28 gauge (0.08 mm²) enables 100 mA input and output sub-bases to be connected directly, as well as sub-bases fitted with relays.
The ABE-7ACC02 adaptor is used to connect 8-channel sub-bases.
- 3 All analogue signal connections are made using a TSX CAP030 pre-wired cable fitted with 25-way SUB-D connectors, which ensure the continuity of the shielding.
- 4 There are several types of sub-base for counter and analogue channels:
 - ABE-7CPA02 for connecting current, voltage or PT100 inputs to screw terminals
 - ABE-7CPA03 with 4-20 mA sensor circuit supply and 25 mA limiter for each channel
 - ABE-7CPA21 for connecting 4-channel analogue output modules to screw terminals
 - ABE-7CPA31 with isolated 4-20 mA sensor circuit supply for 8 individually isolated channels
 - ABE-7CPA11 for connecting an absolute encoder with parallel outputs
 - ABE-7CPA12 for connecting 16 thermocouple probes
- 5 16-channel Telefast sub-bases.
- 6 Splitter sub-bases for the parallel connection of discrete I/O from a Telefast 2 sub-base to 2 different PLCs :
 - ABE-7ACC10 for output redundancy
 - ABE-7ACC11 for input redundancy

(1) The --- 24 V power supply is connected using Telefast sub-bases only. The --- 0 V connections must be equipotential.

Connection interfaces

Telefast® 2 pre-wired system
Modicon TSX Premium PLC I/O modules and interface sub-bases

Premium PLC I/O modules

		24 V discrete						Analogue						Axis control			Counting		Fast counting		Safety		
		Inputs			Outputs			Inputs/outputs			Inputs			Outputs			Thermo-couple inputs	Speed reference	Auxiliary input	Auxiliary inputs	Counter	Auxiliary inputs	Counter
		4x16 I 2x16 I	2x16 I	1x16 I	4x16 Q 2x16 Q	1x16 I	1x12 Q	2x8 I	8 I	4 I	4 Q	8Q	2x8 I										
With modules	TSX	DEY 64D2K 32D2K	DEY 32D3K	DEY 16FK	DSY 64T2K 32T2K	DMY 28 FK 28 RFK		AEY 1600	AEY 800	AEY 810	AEY 420	ASY 410	ASY 800	AEY 1614	CAY1 CFY1	CA CF	CTY1 CTY2				CTY2C		PAY 2x2
Cables with connectors		TSX CDP ^{●●●} 3 or ABF-H20H ^{●●●} 0						TSX CAP030			-			TSX CAP030			TSX CDP ^{●●●} 3		TSX CAP 030	TSX CDP ●●●3	TSX CAP 030		
Cabled conn. with PLC term. blk. supplied		-										(4)	-										

Connection sub-base

8 channels	ABE-7H08R ^{●●}	(1)		(1)	(1)	(1)																H08 R10 (2)					
	ABE-7H08S21	(1)		(1)	(1)	(1)																					
12 channels	ABE-7H12R ^{●●} /7H12S21																										
16 channels	ABE-7H16R ^{●●} /H16C ^{●●} / H20E ^{●●●}		H16 R20																				H16 R20	H16 R20 (3)		H16 R20 (3)	
	ABE-7H16S21																										
	ABE-7H16R23																										
	ABE-7H16F43																										
	ABE-7H16S43																										

Input adaptor sub-bases

16 channels	ABE-7S16E2 ^{●●} /7P16F3 ^{●●}																											
-------------	--	--	--	--	--	--	--	--	--	--	--	--	--	--	--	--	--	--	--	--	--	--	--	--	--	--	--	--

Output adaptor sub-bases

8 channels	ABE-7S08S2 ^{●●} /7R08S ^{●●●}				(1)																							
	ABE-7P08T330				(1)																							
16 channels	ABE-7S16S ^{●●●} /7R16S ^{●●●}																											
	ABE-7R16T ^{●●●} /7P16T ^{●●●}																											

Sub-bases for analogue/counter Inputs

	ABE-7CPA01																											
	ABE-7CPA11																											
	ABE-7CPA02																											
	ABE-7CPA21																											
	ABE-7CPA03																											
	ABE-7CPA31																											
	ABE-7CPA12																											
	ABE-7CPA13																											

- (1) Via splitter sub-base ABE-7ACC02, which allows 16 channels to be split into 2 x 8 channels.
- (2) 1-channel connection.
- (3) 2-channel connection.
- (4) ABF-Y25S200 cabled connector fitted with a TSX BLY terminal block.
- (5) Can only be used with the CAY[●]1 module.
- (6) Only the first 4 channels are used.

 Pre-wired cables

Connection interfaces

Telefast® 2 pre-wired system

Connection cables for Telemecanique TSX 47 to 107 PLCs

4

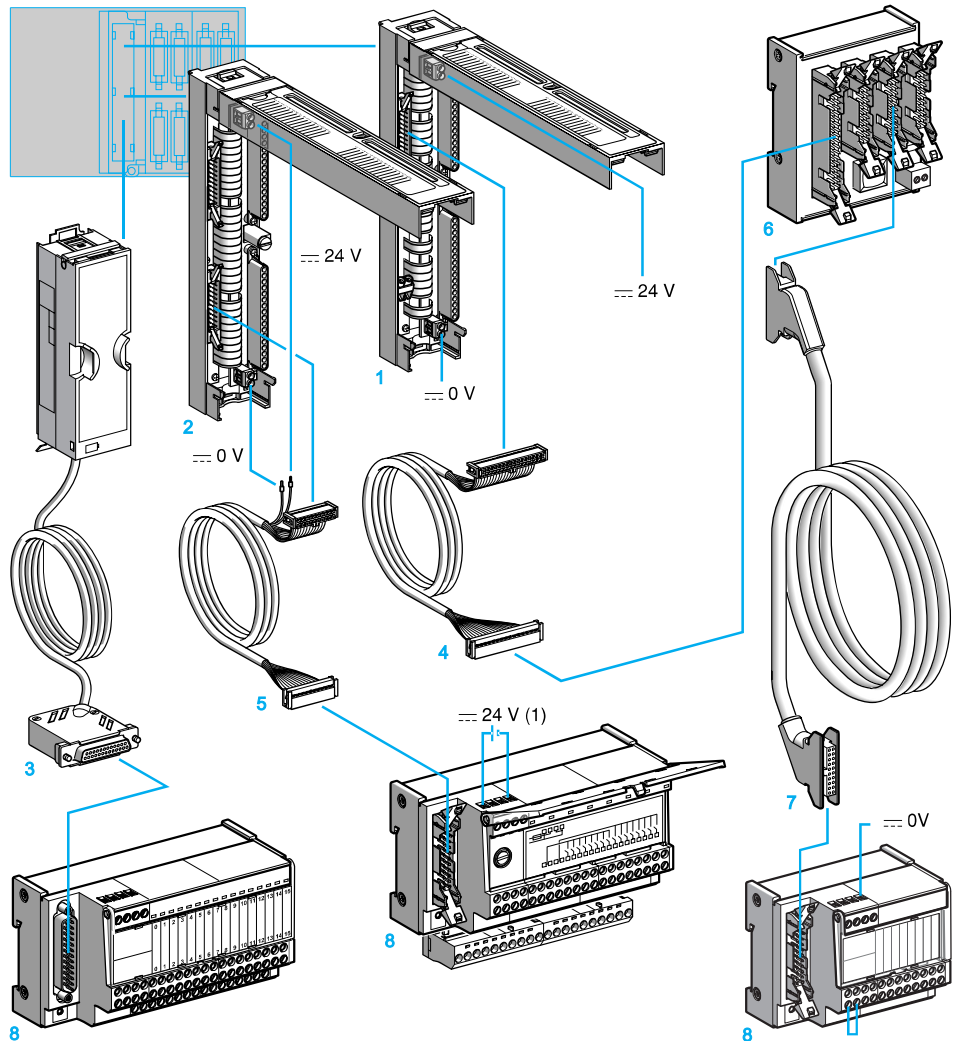

- 1 TSX BLK 81 terminal block connected to TSX DST 24 modules. Outputs are connected using a 34-way HE 10 connector, integrating all 24 channels. The \approx 24 V power can only be supplied via the screw terminals of the terminal block.
- 2 TSX BLK 71/91 terminal blocks connected respectively to TSX DET 32 and TSX DST 3292 modules. I/O are connected using two 20-way HE 10 connectors, each integrating 16 channels.
- 3 ABF-B25S cabled connector, for TSX AEM8 analogue counters, comprising a standard TSX BLK 4 terminal block, a screened multicore cable (AWG 22) and a 25-way SUB-D connector, providing continuity of shielding. An ABF-B50S cabled terminal block, fitted with two SUB-D connectors, enables connection to TSX AEM 160 modules.
- 4 ABF-H34H cables (AWG 28) fitted with 34-way HE 10 connectors, supplied in 1, 2 and 3 metre lengths.
- 5 ABF-H20H connection cable fitted with 20-way HE 10 connectors and a rolled ribbon cable (AWG 28). This cable is used specifically to carry power supplies so that they may be connected to the TSX BLK 71 and TSX BLK 91 terminal blocks. If these cables are used, it is essential that both polarities are connected to the Telefast 2 sub-base.
- 6 ABE-7ACC03 splitter sub-base enabling 24 channels to be connected to Telefast 2 sub-bases with 8-channel modularity. In this case, it is essential to connect the \approx 0 V to the Telefast 2 sub-bases.
- 7 TSX CDP or ABF-H20H cables.
- 8 ABE-7CPA02, ABE-7R16S111 sub-bases with ABE-7BV20 and ABE-7H08R11 terminal blocks. The ABE-7CPA02 sub-base enables the current, voltage or PT 100 inputs to be connected whilst maintaining continuity of shielding.

(1) The \approx 24 V power supply is connected using Telefast 2 sub-bases only. The \approx 0 V connection must be equipotential.

Connection interfaces

Telefast® 2 pre-wired system
I/O modules for Telemecanique TSX 47 to 107 PLCs,
April Series 1000 and interface sub-bases

I/O modules (Series 7 and Series 1000)

		Telemecanique TSX 47 to 107 PLC modules						APRIL Series 1000 PLC modules			
		Discrete			Analogue			Discrete		Analogue	
		Inputs	Outputs		Inputs			Inputs, Outputs < 0.5 A	Outputs = 0.5 A	Inputs	
Integrated in PLCs	TSX	32 channels	32 channels	24 channels		16 channels	16 channels	8 channels	32 channels	32 channels	16 channels
		DET 32 32	DST 32 92	DST 24 72		AEM 16 13	AEM 16 0●	AEM 8 ●●	QDB 32 05	QDB 32 05	DXA 16 00
		TSX DET 32 42	–	DST 24 82		–	–	–	QPA 3205	QPA 3205	IRA 1600
		TSX DET 32 52	–	–		–	–	–	IDB 32 24	–	–
Connection terminal blocks	TSX	BLK 71	BLK 91	BLK 81		None	Included	Included	Included	Included	None
Connection cables	ABF-	H20H●●1				S25S301	B50S●01	B25S●01	A32H●00	A32H●●1	S25S302

Connection sub-bases

8 channels	ABE-7H08R●●/7H08S21	(1)	(1)	(2)					(1)		
12 channels	ABE-7H12R●●/7H12S21										
16 channels	ABE-7H16R●●/7H16S21/ H16C●●/H20E●●●										
	ABE-7H16R23										
	ABE-7H16F43										
	ABE-7H16S43	(4)							(5)		

Input adaptor sub-bases

16 channels	ABE-7S16E2●●/7P16F3●●										
-------------	-----------------------	--	--	--	--	--	--	--	--	--	--

Output adaptor sub-bases

8 channels	ABE-7S08S2●●			(2)					(1)		
	ABE-7R08S●●●/7P08T330		(1)	(2)					(1)		
16 channels	ABE-7S16S●●●		(3)								
	ABE-7R16S●●●										
	ABE-7R16T●●●/7P16T●●●										

Sub-bases for analogue/counter I/O

	ABE-7CPA01										
	ABE-7CPA02										
	ABE-7CPA03										

- (1) Via splitter sub-base ABE-7ACC02 which enables 16 channels to be split into 2 x 8 channels.
- (2) Via splitter sub-base ABE-7ACC03 which enables 24 channels to be split into 3 x 8 channels.
- (3) With module ABE-7S16S2B2 only.
- (4) Except DET 32 52.
- (5) Input only.

 Pre-wired cables

Connection interfaces

Telefast® 2 pre-wired system
Connector cables for Modicon PLCs

4

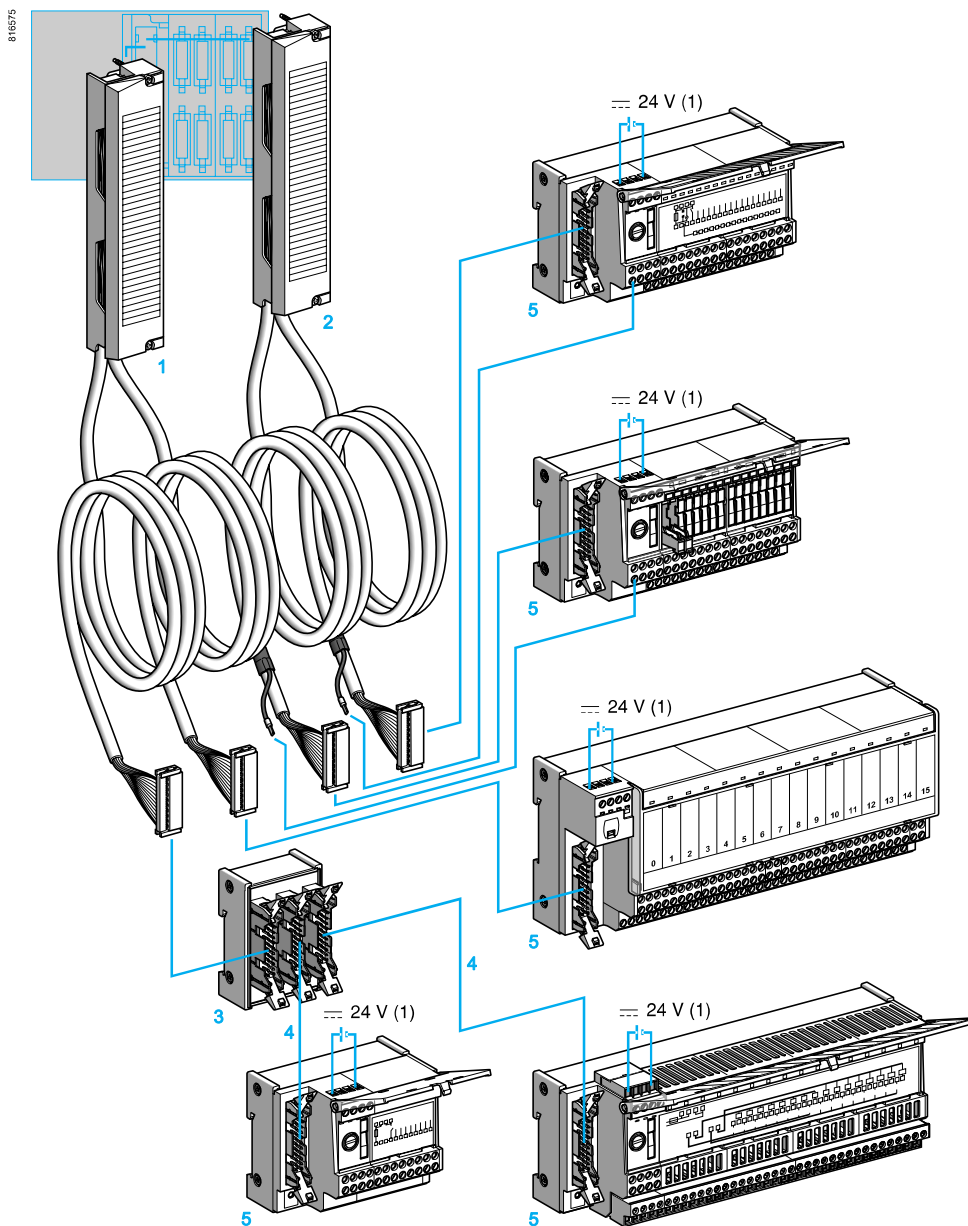

1-2 Cabled connectors combine a standard terminal block equipped with screw terminals, two multicore (AWG 22) cables and two 20-way HE 10 connectors. Two cabled connectors are available for the Quantum range and two others for the 984-A120-Compact range.

The 4 products have the following functions:

- ABF-M32H●●0 **1** for Quantum relay inputs or outputs, with 2 x HE 10 connectors each integrating 16 channels.
- ABF-M32H●●1 **2** for outputs directly connected to the Quantum, with 2 x HE 10 connectors each integrating 16 channels and an external power supply with a direct connection to the output terminal marked 1.
- ABF-M16H●●0 for 984-A120-Compact inputs or relay outputs, with 1 x HE 10 connector each integrating 16 channels.
- ABF-M16Hpp1 for 984-A120-Compact directly connected outputs, with 2 x HE 10 connectors each integrating 8 channels.

3 The splitter sub-base ABE-7ACC02 may be used to connect sub-bases with 8-channel modularity.

4 A single type of cable equipped with 20-way HE 10 connectors irrespective of the 8, 12 or 16-channel modularity. The HE 10 connectors may be moulded (TSX-CDP●●●) or self-perforating (ABF-H20H●●●).

5 8 and 16-channel sub-bases from the Telefast 2 range.

(1) The 24 V power supply is connected using Telefast 2 sub-bases only. The 0 V connections must be equipotential.

Connection interfaces

Telefast® 2 pre-wired system
Modicon PLC and NUM numerical control I/O modules with interface sub-bases

I/O modules	Modicon PLCs														NUM numerical controllers												
	984-A120-Compact										Quantum				NUM 1050/1060		NUM 1020										
	Inputs					Outputs					TOR In-put		TOR Out-put		Analogue Inputs		Outputs		Inputs/Outputs		Inputs/Outputs						
	16 E		16 S			32 E		32 S			96 E		96 S		8 E		16E		4 S		8 S		64 E + 48 S		32 E + 24 S		
	DEP 220	DEP 217	DAO 216	DAO 216	DAP 216	DDI 353	DDI 853	DDO 353		DDI 384	DDO 384	140 AVI 03000	140 ACI 04000	140 AVO 02000	140 ACO 02000	140 ACO 13000			64 I	48 O	32 I	24 O					
Connection terminal blocks	Included														NUM cables not supplied												
Cabled connectors	ABF-M16 H00		M16 H001			M32 H00		M32 H001			-		M08 S201	M16 S201	M04 S200	M04 S201	M08 S202			-	-	-	-				
Splitter sub-bases	ABE-7		-			-		-			CDP003		-		-		-		ACC04	ACC05	ACC04	ACC05					

Connection sub-bases

8 channels	ABE-7H08R00	(5)	(1)			(1)	(2)			(2)									(2)		(2)				
	ABE-7H08S21	(5)								(2)									(2)		(2)				
12 channels	ABE-7H12R00																								
	ABE-7H12S21																								
16 channels	ABE-7H16R00/H16C00		(1)																						
	ABE-7H16S21																								
	ABE-7H16R23					(4)																			
	ABE-7H16F43																								
	ABE-7H16S43					(3)																			

Input adaptor sub-bases

16 channels	ABE-7S16E200/7P16F300																								
	ABE-7P08T330						(2)																		

Output adaptor sub-bases

8 channels	ABE-7S08S200									(2)															
	ABE-7R08S000/7P08T330						(2)			(2)															
16 channels	ABE-7R16S000																								
	ABE-7R16T000/7P16T330																								
	ABE-7S16S000																								

Sub-bases for analogue/counter I/O

	ABE-7CPA01																								
	ABE-7CPA02											(6)													
	ABE-7CPA03											(6)													
	ABE-7CPA21																								
	ABE-7CPA31												(6)												

- (1) With Telefast 2 sub-bases with no channel LED.
- (2) With the splitter sub-base ABE-7ACC02.
- (3) Only with module DDI 853.
- (4) Only with module DDI 353.
- (5) With the splitter sub-base ABE-7ACC02 or with a cabled connector ABF-M16H001 directly.
- (6) 2 sub-bases are required.

Pre-wired cabled connectors



Connection interfaces

Telefast® 2 pre-wired system
 Connection cables for Allen Bradley SLC500 PLCs
 Connection cables for Siemens S5 PLCs

4

Connection cables for Allen Bradley SLC500 PLCs

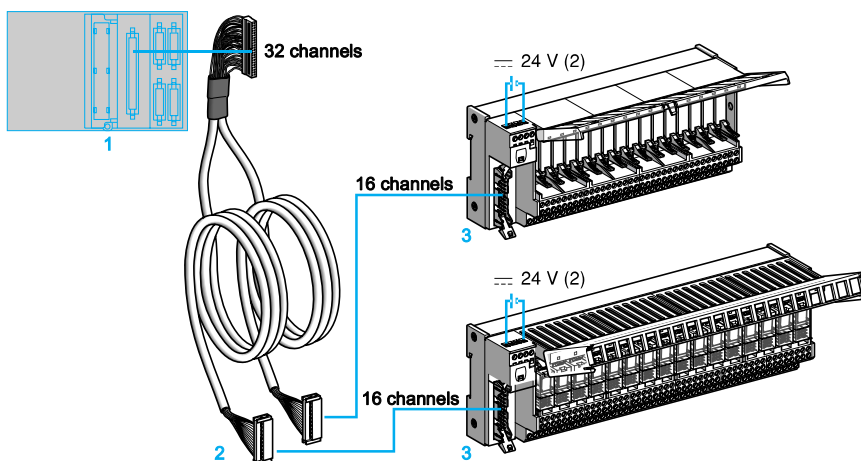

- 1 For the SLC500 range, the specially designed cables connect to the I/O modules which are equipped with 40-way HE 10 connectors, integrating 32 channels.
- 2 Cables ABF-H40H●●● to connect 16-channel sub-bases. They are supplied with one 40-way HE 10 connector, at the PLC end and 2 x 20-way HE 10 connectors, at the Telefast end. Available in 1.5 and 3 metre lengths, AWG 22, there are 2 types of "Y" form cables: one exclusively for inputs and one for outputs.
- 3 16-channel sub-bases. It is possible to use 8-channel sub-bases by inserting adaptor ABE-7ACC02.

Connection cables for Siemens S5 PLCs

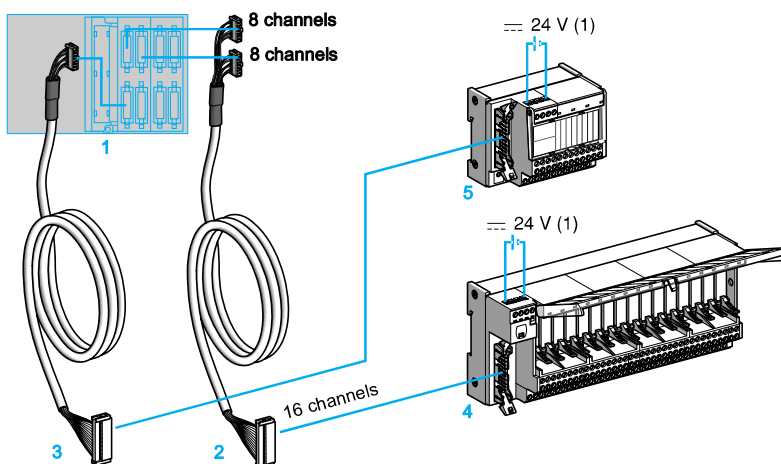

- 1 The \sim 24 V power supply may be provided via 6EP5-●●● terminal blocks connected to the PLC modules. For the 95U/100U/115U/135U/155U ranges, manufacturers cables are connected to terminal blocks via 14-way HE 10 connectors (6EP5-●●●-1AA00). Each connector integrates 8 channels.
- 2 Cables ABF-H28H●●● to connect 16-channel sub-bases. They are supplied with 2 x 14-way HE 10 connectors, fitted at the S5 PLC end and one 20-way HE 10 connector, at the Telefast end. Available in 1.5 and 3 metre lengths, AWG 26, these "Y" form cables only connect the I/O controlling the relay sub-bases.
- 3 Cables ABF-H14H●●● to connect 16-channel sub-bases. They are supplied with one 14-way HE 10 connector, at the S5 PLC end and one 20-way HE 10 connector, at the Telefast end. Available in 1.5 and 3 metre lengths, AWG 26, these cables are used to connect the I/O directly to the sub-bases.

(1) The \sim 24 V power supply is connected using Telefast sub-bases only. The \sim 0 V connections must be equipotential.
 (2) The power may be supplied via the PLC terminal block or the Telefast sub-base.

Connection interfaces

Telefast® 2 pre-wired system
Allen Bradley and Siemens S5 PLC I/O modules

I/O modules for Allen Bradley and Siemens S5 PLCs

		Allen Bradley					Siemens											
		SLC500					S5-95U/100U					S5-115U		S5-135U/155U				
		Input		Output			I/O	Input	Input	Output	Ana. Inp.	Input	Output	Input	Output	Ana. Inp.	Ana. out	
		32 I	16 I	16 Q	32 Q	1746	16 I + 16 Q	16 I	8 I	8 Q	4 I	32 I	32 Q	32 I	32 Q	8 I	8 Q	
Integral to the PLCs		1746 IB32	1746 IB16	1746 OB16	1746 OB32	1746 OV32	6ES5-095 8MA03 6ES-5-482 8MA13	6ES5-422 8MA11	6ES5-421 8MA12	6ES5-441 8MA11	6ES5-464 8ME11	6ES5-430 7LA12	6ES5-441 7LA11	6ES5-460 4UA14	6ES5-470 4UA13	6ES5-470 4UA12		
	Connection terminal blocks	None					6EP5-100-1AA00	6EP5-100-1AA00	Included	Included	6ES5-700-8MA11	6EP5-115-1AA00	6EP5-115-1AA00	6EP5-135-1AA00	6EP5-135-1AA00	6ES5-497-4UB12	6ES5-497-4UB12	
Connection cables Modularity	16 channels	ABF-H40H00	R16 H201	R16 H200	H40H00		H28H00	H28H00				H28H00		H28H00				
	8 channels	ABF-H14H00					H14H00	H14H00	S16H00	S16H00		H14H00	H14H00	H14H00	H14H00			
	(7) ABF-										F25S200					F25S200	F25S200	

Connection sub-bases

8 channels	ABE-7H08R00	(2)	(2)		(2)	(1) (2)												
	ABE-7H08S21	(2)	(2)		(2)													
12 channels	ABE-7H12R00/7H12S21																	
16 channels	ABE-7H16R00/16C00			(5)		(1) (4)												
	ABE-7H16S21					(4)												
	ABE-7H16R23																	
	ABE-7H16F43																	
	ABE-7H16S43																	

Input adaptation sub-bases

16 channels	ABE-7S16E200/7P16F300																	
-------------	-----------------------	--	--	--	--	--	--	--	--	--	--	--	--	--	--	--	--	--

Output adaptation sub-bases

8 channels	ABE-7S08S200																	
	ABE-7R08S000				(2)													
	ABE-7P08T330				(2)						(2)		(2)					
16 channels	ABE-7R16S000/7R16T000																	
	ABE-7P16T000 (6)																	
	ABE-7S16S000				(3)		(3)				(3)		(3)					

Sub-bases for analogue/counter I/O

	ABE-7CPA01																	
	ABE-7CPA02																	
	ABE-7CPA03																	
	ABE-7CPA21																	

(1) With Telefast 2 sub-bases with no channel LED.

(2) With splitter sub-base ABE-7ACC02.

(3) Sub-base ABE-7S16S2B2 only.

(4) Input only.

Pre-wired cables

(5) Power supply --- 24 V without cable.

(6) Do not use with ABE-7ACC21/20.

(7) Cable with 25-way SUB-D connector at Telefast end. Labelled bare wires at PLC end.

Connection interfaces

Telefast® 2 pre-wired system
 Connection cables for Siemens S7 PLCs

Connection cables for Siemens S7 PLCs

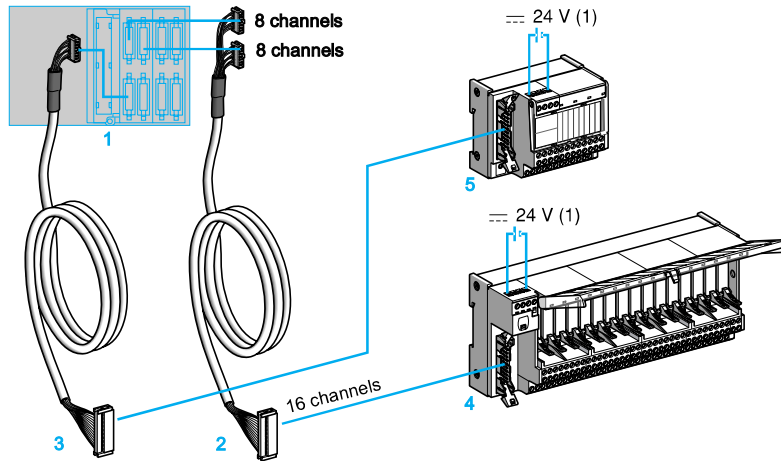

- 1 The \sim 24 V power supply may be provided via 6EP5-... terminal blocks connected to the PLC modules. For the S7200/300/400 ranges, manufacturers cables are connected to terminal blocks via 16-way HE 10 connectors (6EP5-...-1AA00). Each connector integrates 8 channels.
- 2 Cables ABF-H28H... to connect 16-channel sub-bases. They are supplied with 2 x 16-way HE 10 connectors, fitted at the S7 PLC end and one 20-way HE 10 connector, at the Telefast end. Available in 1.5 and 3 metre lengths, AWG 26, these "Y" form cables only connect the I/O controlling the relay sub-bases.
- 3 Cables ABF-H14H... to connect 8-channel sub-bases. They are supplied with one 14-way HE 10 connector, at the S7 PLC end and one 20-way HE 10 connector, at the Telefast end. Available in 1.5 and 3 metre lengths, AWG 26, these cables are used to connect the I/O directly to the sub-bases.

(1) The power may be supplied via the PLC terminal block or the Telefast sub-base.

Connection interfaces

Telefast® 2 pre-wired system
Siemens S7 PLC I/O modules

I/O modules for Siemens S7 PLCs

		Siemens											
		S7-200				S7-300				S7-400		00	
		Input/Output 14 I + 10 Q	Input 8 I	Output 8 Q	Input 16 I	Input 32 I	Output 16 Q	Output 32 Q	Ana. out. 4 Q	Input 32 I	Output 32 Q	Ana. inp. 8 I	Ana. out. 8 Q
Integral to the PLCs	6ES7-	214-1AC01-0XB0	221-1BF00-0XA0	222-1BF00-0XA0	321-1BH01-0AA0	321-1BL00-0AA0	322-1BH01-0AA0	322-1BL00-0AA0	332-5HD01-0AA0	421-1BL00-0AA0	422-1BL00-0AA0	431-1KF00-0AB0	432-1HF00-0AB0
Connection terminal blocks	6ES7-	Included	Included	Included	921-3AB00-0AA0	921-3AA20-0AA0	921-3AB00-0AA0	921-3AA20-0AA0	392-1AJ00-0AA0	921-4AB00-0AA0	921-4AB00-0AA0	492-1AL00-0AA0	492-1AL00-0AA0
Connection cables													
Modularity	16 channels	ABF-			H32 Hee0	H32 Hee0	H32 Hee0	H32 Hee0		H32 Hee0	H32 Hee0		
	8 channels	ABF-	S08 Hee2	S08 Hee3	H16 Hee0	H16 Hee0	H16 Hee0	H16 Hee0		H16 Hee0	H16 Hee0		
	Others	ABF-	S24 Hee0						F25 S200 (4)			F25 S200 (4)	F25 S200 (4)

Connection sub-bases

8 channels	ABE-7H08R●●/7H08S21												
12 channels	ABE-7H12R●●												
	ABE-7H12S21												
16 channels	ABE-7H16R●●/32E●●●/16C●●												
	ABE-7H16S21												
	ABE-7H16R23/7H16F43												
	ABE-7H16S43												

Input adaptation sub-bases

16 channels	ABE-7S16E2●●/7P16F3●●												
-------------	-----------------------	--	--	--	--	--	--	--	--	--	--	--	--

Output adaptation sub-bases

8 channels	ABE-7S08S2●●												
	ABE-7R08S●●●												
	ABE-7P08T330							(1)			(1)		
16 channels	ABE-7R16S●●●												
	ABE-7R16T●●●												
	ABE-7P16T●●● (3)												
	ABE-7S16S●●●							(2)	(2)		(2)		

Sub-bases for analogue/counter I/O

	ABE-7CPA01												
	ABE-7CPA02												
	ABE-7CPA03												
	ABE-7CPA21												

(1) With splitter sub-base ABE-7ACC02.

(2) Sub-base ABE-7S16S2B2 only.

(3) Do not use with ABE-7ACC21/20.

(4) Cable with 25-way SUB-D connector at Telefast end. Labelled bare wires at PLC end (see diagram on page 4/62)

 Pre-wired cables

4

Sub-base/removable output relay compatibility

Relay for sub-bases ABE-7●16T●●	Relay width 10 mm					Relay width 5 mm	
Relay	ABR-7S21	ABR-7S23	ABS-7SA2M	ABS-7SC2E	ABE-7ACC20	ABR-7S11	ABS-7SC1B
Function	Relay 1 N/O	Relay 1 C/O	Output ~ 230 V-0.5 A	Output ≡ 48 V-0.5 A	Continuity 0.5 A	Relay 1 N/O	Output ≡ 24 V-2 A

Sub-bases/modules

ABE-7●16T210		no effect					
ABE-7●16T111/M111							
ABE-7●16T212		no effect					
ABE-7●16T214		no effect					
ABE-7●16T215		no effect					
ABE-7●16T230							
ABE-7●16T231							

12.5 mm wide relays for sub-bases ABE-7●16T3●●

Relay	ABR-7S33	ABR-7S37	ABS-7SA3M	ABS-7SC3E	ABS-7SC3BA	ABE-7ACC21 (1)
Function	Relay 1 C/O	Relay 2 C/O	Output ~ 230 V-1.5 A	Output ≡ 48 V-1.5 A	Output ≡ 24 V-2A Protected	Continuity 0.5 A

Sub-bases/modules

ABE-7●16T318						
ABE-7●16T330						
ABE-7●16T332						
ABE-7●16T334						
ABE-7●16T370						
ABE-7P08T330						

Compatible

(1) Product mounted on removable input sub-bases ABE-7P16F3●●

General system environment

Approvals	UL, CSA		Entire range of sub-bases, except ABE-7●●●●E. Sub-bases with fixed screw terminal block only.
	LR0S, BV, GL, DNV		
Degree of protection	Conforming to IEC 60529		IP 2X
Protective treatment			"TC"
Resistance to incandescent wire	Conforming to IEC 60695-2-11	°C	750: extinguish time < 30 s
Shock resistance	Conforming to IEC 60068-2-27	ms	11 (half sine wave), 15 g (acceleration)
Vibration resistance	Conforming to IEC 60068-2-6	Hz	10...150, 2 g (acceleration)
Resistance to electrostatic discharge	Conforming to IEC 61000-4-2		Level 3
Resistance to radiated fields	Conforming to IEC 61000-4-3	MHz V/m	26...1000-Level 3 10
Resistance to fast transients	Conforming to IEC 61000-4-4		Level 3
Resistance to shockwaves	Conforming to IEC 61000-4-5	µs	1.2/50 - 8/20
Ambient air temperature	For operation, conforming to IEC 61131-2	°C	- 5...+ 60
	For storage, conforming to IEC 61131-2	°C	- 40...+ 80
Insulation voltage (for 1 minute)	Terminal/mounting rails	kV	2
Installation category	Conforming to IEC 60664-1		II
Degree of pollution	Conforming to IEC 60664-1		2
Mounting	Standard rail (conforming to IEC 60715)		15 mm high rail or solid plate with ABE-7ACC01
			1 conductor 2 conductors (1)
Cable c.s.a. Screw or spring terminals	Flexible cable without cable end	mm ² AWG	0.14...2.5 26...14 -
	Flexible cable with cable end	mm ² AWG	0.09...1.5 28...16 0.09...0.75 28...20
	Solid cable	mm ² AWG	0.14...2.5 26...12 0.2...2.5 24...14
Tightening torque	Using 3.5 mm screwdriver blade	Nm	0.6

(1) On screw terminal blocks only.

Presentation, compatibility:
pages 4/8 to 4/23

References :
pages 4/36 to 4/49

Dimensions, schemes :
pages 4/52 to 4/63

Connection interfaces

Telefast® 2 pre-wired system
 Passive connection sub-bases for discrete signals
 Removable relay sub-bases, equipped or non equipped

General characteristics

Type of sub-base	Passive connection sub-base for discrete signals							Removable relay sub-bases			
	H20E●●● H32E●●●	H16C●● H16CM	H16R●● H16S21 H16C31	H16R23	H16F43 H16S43	H12R●● H12S21	H08R●● H08S21	R16T2●● P16T2●● ●16T111 ●16M111	R16T3●● P08T330 P16T3●●	R16T370	P16F31●
Number of channels	16	16	16	16	16	12	8	16/8	16/8	16	16
Function											
Input	●	H16C	●	Type2(1)	H16S43	●	●	–	–	–	●
Output	●	H16C	●	–	H16F43	●	●	R16T2●● P16T2●● ●16T111 ●16M111	●	●	–
Input and output	–	H16CM●1	–	–	–	–	–	●16M111	–	–	–
Channel and power supply indication	Via green LED (for products equipped with indication)										
Blown fuse indication	–				Via red LED		–				

Power supply characteristics (PLC end)

Supply voltage	---	V	19 to 30 conforming to IEC 61131-2 (Un = 24)								
Maximum permissible supply current to each sub-base	---	A	1.8			6.1		4.1		1	
Voltage drop on power supply fuse	---	V	0.3			0.2		0.3			
Protection against power supply overloads and short-circuits by quick-blow fuse (supplied)	A		2		F43: 2 S43: 1		6.3		1		

Output circuit characteristics

Maximum voltage drop per channel	---	V	–			F43: 2 S43: 0.1		–		See relay characteristics on page 4/29			
Maximum permissible current per channel	---	mA	500			125		500		See temperature derating curves on page 4/32			
Maximum permissible current per output common	---	A	1.8			6.1		4.1		16 (screw terminals) 12 (spring terminals)		–	
Current drawn by channel LED at Un	---	mA	3.2		10		3.2						
Permissible leakage current without illuminating channel LED (PLC I/O connected)	---	mA	1.5		4		1.5						
Opening of blade isolators	Under no load												
Channel fuse protection (supplied with product)	A		–			0.125		–		0.5 (2)		2 (2)	–
Rated Insulation voltage conforming to IEC 60947-1 Coil circuit/contact circuits	V		–								300		
Rated impulse withstand voltage (1.2/50)	kV		–								2.5		

(1) Compatible with Modicon TSX Micro and Premium PLC inputs only, for connection of 2-wire sensors, d.c.
 (2) If the sub-bases are supplied with fuses (depending on model).

Connection interfaces

Telefast® 2 pre-wired system
 Solid state input sub-bases, soldered
 Removable input relays

Type of sub-base and relay	Solid state input sub-bases, soldered					Removable input relays							E.M. (1)
	ABE-7S16					ABS-7							
	E2B1	E2E1	E2E0	E2F0	E2M0	EC3AL	EC3B2	EC3E2	EA3E5	EA3F5	EA3M5	S33E	
	-					For mounting on sub-bases ABE-7P16F31●							

Control circuit characteristics for 1 channel (sensor end)

Rated voltage U_s	\equiv V	24	48	-	-	-	5 (TTL)	24	48	-	-	-	48
	50/60 Hz \sim V	-	-	48	110/130	230/240	-	-	-	48	110/130	230/240	-
Maximum voltage (IEC 61131-2) (including ripple)	\equiv V	30	60	-	-	-	6	30	60	-	-	-	60
	\sim V	-	-	53	143	264	-	-	-	53	143	264	-
Maximum current (Ie) at U_s	\equiv mA	12	13	-	-	-	15	15	15	-	-	-	13
	\sim mA	-	-	12	8.3	8	-	-	-	12	8.3	8	-
State 1 guaranteed $U \geq \dots / I \geq \dots$	\equiv V/mA	15/2	30/6	-	-	-	3.75/4.5	11/6	30/6	-	-	-	34/8.2
	\sim V/mA	-	-	32/5	79/5	164/4.5	-	-	-	32/5	79/5	164/4.5	-
State 0 guaranteed $U \leq \dots / I \leq \dots$	\equiv V/mA	5/2	10/2	-	-	-	2/0.09	5/2	10/2	-	-	-	3.6/0.8
	\sim V/mA	-	-	10/1.5	30/2	40/2	-	-	-	10/1.5	30/2	40/2	-
Conforming to IEC 61131-2		Type 1	Type 2	Type 1	Type 1	Type 1	-	Type 2	Type 2	Type 1	Type 1	Type 1	-
External protection	Quick-blow fuse (sized according to sensors)												
Removable terminal block	Yes						No						

Output circuit characteristics (PLC end)

Rated operational voltage U_e	\equiv V	24											
Minimum/maximum voltage (IEC 61131-2)	\equiv V	19/30											
Minimum/maximum switching current	\equiv mA	1/15											
Maximum residual current at state 0	\equiv mA	0.1											
Maximum voltage drop at state 1	\equiv V	1											
Internal protection		Against short-circuits	-										
Power supply protection		5 x 20 quick-blow fuse, 1 A											

Other characteristics

Maximum response time	0 → 1	ms	0.05	20	0.05	20	13 (2)
	1 → 0	ms	0.4	20	0.4	20	13 (2)
Maximum switching rate Duty cycle 50 %	Hz	1000	25	1000	25	5 (no load) 0.5 (at Ie)	
Dielectric strength to IEC 60947-1 Between input/output	V	2000 (50/60 Hz) - 1 mm					
Rated impulse withstand voltage (1.2/50) to IEC 60947-1 Input/output	kV	2.5					
Mechanical durability In millions of operating cycles		-					20

(1) Electromechanical.
 (2) Including bounce (max. 1.6 ms).

Type of sub-base and relay	Solid state output sub-bases, soldered			Removable solid state output relays					
	ABE-7S			ABS-7					
	●●S2B0 (1)	16S1B2	08S2B1 (1)	SC1B	SC2E	SA2M	SC3BA	SC3E	SA3M
	-			-	For sub-base ABE-7●16T21●		For mounting on sub-base ABE-7●16T3●●		

Control circuit characteristics for 1 channel (PLC end)

Number of channels		8 or 16	16	8	-	-	-	-	-	-
Rated voltage Us	≡ V	24								
Min/max voltage (IEC 61131-2)	≡ V	19/30								
Current per channel at Us (Channel + LED)	≡ mA	4.5 (including LED)			7 + 3.2	4 + 3.2	9 + 3.2	4 + 3.2	4 + 3.2	9 + 3.2
State 1 guaranteed (2)	≡ V	16.9			16	18.6		-	-	-
	≡ mA	3.1			5.5	2.9	6.5	2.9	2.9	6.5
State 0 guaranteed	≡ V	3.4			10	3.8	2.8	3.8	3.8	2.8
	≡ mA	0.4			-	-	-	-	-	-
Compatible with PLC output (1)	≡ mA	≤ 100	-	≤ 500	All types of output					
Power supply protection		2 A quick-blow fuse			See sub-base characteristics page 4/27					

Output circuit characteristics (preactor end)

Maximum current per common	Spring	A	≡ 8	≡ 9	≡ 10	-	≡ 12	~ 12	≡ 12	≡ 12	~ 12
	Screw	A	≡ 8	≡ 9	≡ 10	12	≡ 16	~ 16	≡ 16	≡ 16	~ 16
Switching current per channel (5)		A	≡ 0.5	≡ 0.7	≡ 2	≡ 2	≡ 0.5	~ 0.5	≡ 2	≡ 1.5	~ 1.5
Rated operational voltage Ue		V	24			≡ 24	≡ 5-48	~ 24/240	≡ 24	≡ 5 to 48	~ 24 to 240
Maximum voltage (IEC 61131-2)		V	30			≡ 30	≡ 57.6	~ 264	≡ 30	≡ 60	~ 264
Maximum residual voltage at In		V	0.6	0.3	0.5	≡ 0.12	≡ 1	~ 1.1	0.3	≡ 1.3	~ 1.3
Rated operational current Ie ≤ 60 °C Maximum per channel	DC12	A	0.5	0.7	2	2	0.5	-	2	1.5	-
	DC13	A	0.5	0.7	1 (3)	2	0.5	-	2	1.5	-
	AC12	A	-	-	-	-	-	0.5	-	-	1.5
	AC14	A	-	-	-	-	-	0.5	-	-	0.7
	DC6	W	10	-	-	-	10	-	10	-	-
Minimum current per channel		mA	1			≡ 1	≡ 1	~ 10	≡ 10	≡ 1	~ 10
Maximum residual current		mA	0.3	0.5	-	0.1	≡ 0.5	~ 2	≡ 2	≡ 0.3	~ 2
Faults detected			Auto-protected Overload and short-circuit			-	-	-	Auto-protected Overload & short-circuit	-	-
Report of fault detected (4)			Yes	No	Yes	Non	-	-	-	-	-
Switchable inductive energy L/R (without additional discharge device)		ms	≤ 400/(U.I)		≤ 1700/(U.I)	2 (U.I)	-	-	≤ 1700/(U.I)	-	-
Circuit-breaker threshold		A	≥ 0.75		≥ 2.6	-	-	-	2.5	-	-
External protection			By adjustable quick-blow fuse								
Removable terminal block			Yes			No					

Other characteristics

Rated Insulation voltage Conforming to IEC 60947-1	V	Not insulated			300						
Maximum response times on resistive loads	0 → 1	ms	0.1	0.2	0.1	0.01	0.1	10	0.2	0.1	10
	1 → 0	ms	0.02	0.1	0.02	0.4	0.6	10	0.1	0.6	10
Switching frequency on inductive loads	Hz	< 0.6/ Lp			< 0.5/ Lp	300					
Rated impulse withstand voltage	V	-			2.5	-					

- (1) Only for use on PLC modules (output interfaces) with integral protection (auto-protected outputs).
 (2) On versions with LED indication.
 (3) With free-wheel diode on load, the DC13 value is equal to the value of DC12 x 0.9.
 (4) A fault on a sub-base output Qn will set PLC output Qn to safety mode, which will be detected by the PLC.
 (5) See derating curves page 4/32.

Connection interfaces

Telefast® 2 pre-wired system
 Electromechanical output relay sub-bases, soldered
 Removable electromechanical output relays

Type of sub-base and relay	E.M. output relay sub-bases, soldered			Removable electromechanical output relays				
	ABE-7			ABR-7				
	R00S111	R00S210	R00S216	S21	S23	S33	S37	S11
			For mounting on sub-base ABE-7					
			P16T210	P16T230	P16T300	R16T370	P16T111	P16M111

Control circuit characteristics for 1 channel (PLC end)

Rated voltage Us		V	24					
Tripping threshold at 40 °C		V	19.2	19.7	19.2 (1)	19.7	16.8	16.8
Drop-out voltage at 20 °C		V	2.4			2.4	3.6	2
Maximum operational voltage		V	30					
Maximum current at Us per channel	Coil + LED	mA	9 + 3.2	15 + 3.2	12.5 + 3.2	15 + 3.2	25 + 3.2	7 + 3.2
Drop-out current at 20 °C		mA	0.5	1	–	1	3.5	0.5
Maximum dissipated power at Us		W	0.22	0.36	0.3	0.36	0.6	0.170
Loss of voltage	Max. time not affecting the hold	ms	5		3	5		1
Power supply protection			1A quick-blow fuse					

Contact characteristics (preactuator side, at ambient temperature of 20 °C)

Contact composition			1N/O	1N/O	1N/O	1N/O	1C/O	1C/O	2C/O	1N/O
Maximum switching voltage	To IEC 60947-5-1	V	250		380	250		264		250
		V	30		220	130		130		30
Frequency of operational current		Hz	50/60							
			4 (08S111)		Volt-free		4		4	
			8 (16S111)		8					
Maximum current per channel (limited by sub-base)	Volt-free	A	–	5	2 A	5	5	5	5	5
	With common	A	2	4	–	4	4	5	–	3
Maximum current per common	Screw	A	12	10	–	16	16	12		12
	Spring	A	12	10	–	12	–	12		–
Relay maximum current (Ith)		A	2	5	5	5	5	10	8	6
Current for 500 000 operating cycles	24 V DC 12	A	0.6	1.5	2	1.5	1.2	3	2.5	3
	24 V L/R = 10 ms DC 13	A	0.2	0.6	1.5	0.6	0.45	1.4	1	0.5
	230 V AC 12	A	0.6	1.5	2	1.5	1.2	3	2.5	2
	230 V AC 15	A	0.4	0.9	1	0.9	0.7	1.7	1.3	0.4
Minimum switching current	At 5 V minimum voltage	mA	1	10	2	10		100		100
Short-circuit protection	For I _k < 1 kA (–) and < 100 A (–)		High breaking capacity fuse							
Fuse fitted as standard/channel		A	–		–	0.5		2		–
Low level contact reliability			17 V/5 mA		10 V/2 mA	17 V/10 mA				Please consult us
Number of faults	(1/n million operating cycles)		1/100		1/2	1/100		1/100		
Removable terminal block			Yes			No				

Other characteristics (at ambient temperature of 20 °C)

Maximum operating time at Us (including bounce)	Between energisation of the coil and closing of the N/O contact	ms	10		5	10		13	15	5
	Between de-energisation of the coil and opening of the N/O contact	ms	6	5	4	5		13	20	2.5
Maximum bounce time	N/O contact	ms	5		2	5		1.6	4	1.5
	N/C contact	ms	–		–	–	7.5	5.5	7.5	–
Maximum operating rate	No load		10 Hz		180/min	10 Hz		5 Hz		1200/min
	At I _e		0.5 Hz		30/min	0.5 Hz				6/min
Mechanical durability	In millions of operating cycles		20		20	20				20
Dielectric strength	Conforming to IEC 60947-1	V	2000 (50/60 Hz) - 1 mm							4
Rated impulse withstand voltage (1.2/50)	Conforming to IEC 60947-1	kV	2.5		5	2.5				6
(1) latching										

Presentation, compatibility: pages 4/8 to 4/23

References : pages 4/36 to 4/49

Dimensions, schemes : pages 4/52 to 4/63

General characteristics

Type of accessory	ABE-7	ACC02	ACC20 (1)	ACC21 (1)	ACC80	ACC81	ACC82	ACC83	BV10	BV20
Description		Splitter sub-base	Removable continuity blocks with internal fuse		Enclosure feedthrough				Additional clip-In terminal block	
Number of channels		16/2 x 8	1	1	32/2 x 16	32/2 x 16	16	8 or 12	8	16
Type of connector/number of ways at PLC end		1 x HE 10 20-way	–	–	2 x HE 10 20-way	–	1 x HE 10 20-way	1 x HE 10 20-way	–	–
Type of connector/number of ways at operative part end		2 x HE 10 20-way	–	–	Industrial 40-way Female	Male	Cylind. M23 CNOMO 19-way, female		–	–
Min/max connectable c.s.a.	mm ²	–	–	–	0.75/2.5	0.5/1.5	0.75/2.5		0.14/2.5	
Min/max cable diameter	mm	–	–	–	–	10...19	–		–	
Type of terminal block		–	–	–	Spring or screw	Spring or screw	Spring or screw	Spring or screw	Screw	Screw
Protection Index		IP 20	IP 20	IP 20	IP 65	IP 65	IP 65	IP 65	IP 65	IP 65
Rated voltage Us	V	– 24	– 24	– 24	– 24	– 24	– 24	– 24	– 24	– 24
Maximum current at Us per channel	A	0.5	–	–	0.5	0.5	0.5	0.5	0.5	0.5
Maximum supply current at Us	A	2	–	–	4 (2 x HE 10)	4	2	6	16	16
Switching capacity	A	–	0.5	–	–	–	–	–	–	–
Circuit-breaker threshold	V	–	0.5	–	–	–	–	–	–	–

General characteristics (continued)

Type of sub-base	ABE-7	CPA01	CPA11	CPA12	CPA02	CPA21	CPA03	CPA31	CPA13	TES 160
Description		Analogue counter	Counter/motion	Thermo-couple	Analogue signal connection sub-base				Safety	Simulation and forcing sub-base
Number of channels		(2)	1	16 (Telefast CJC mode) (3) 14 (external CJC mode)	8 passive connection point to point	4 passive connection point to point	8 sensor supply distribution	8 isolated, isolated sens. supply distribution	12 double contact emergency stops	16
Protection Index		IP 20								
Power supply	V	–	11...30 5...6	–	–	–	24 IEC	24 IEC Isolated –/–	24 IEC –20+25 %	–
Automatic limitation perchannel	mA	–	–	–	–	–	25	–	–	–
Maximum consumption	mA	–	130	–	–	–	300	–	–	–
Operating temperature	°C	–	0...60	–	–	–	–	–	–10...+ 60	–
Dielectric strength, channel/earth	V	–	1000	–	–	–	1000	–	700	–
Isolation between channels	V	–	–	–	–	–	1000	–	–	–
Logic		Positive or negative (4)								
Compatibility with encoder output		Totem-pole 10...30 V 5V DC RS422	Totem-pole 11...30 V TTL 5 V transistors open collectors 11...30 V	–	–	–	–	–	–	–
Low input voltage (VIL)	V	–	0<VIL<2.4	–	–	–	–	–	–	–
High input voltage (VIH)	V	–	3.9<VIH<30	–	–	–	–	–	–	–
Connection, process side		Fixed screw terminal block						Removable screw term.	Fixed screw terminals	–
Connection, PLC side		SUB D 15-way female	SUB D 15-way male	2 x SUB D 25-way male	1 x SUB D, 25-way male			–	1 x SUB D 50-way	1 x HE 10, 20-way and screw term.
Overvoltage protection on current inputs		–	–	–	–	–	Zener 8.5 V		–	
Current loop continuity		–	–	–	–	–	Zener 8.5 V		–	
Maximum overvoltage on inputs	V	–	–	–	–	–	± 30		–	
Maximum current on inputs	mA	–	–	–	–	–	± 30		–	
Standards		–	–	–	–	–	IEC 601131, CSA22 2, UL 508 (5)			
Permissible common mode voltage between channels	V	–	–	– 250	–	–	–	–	–	
Permissible common mode voltage between channel and earth	V	–	–	– 250	–	–	–	–	–	
Maximum current on integrated commons	A	–	–	–	–	–	–	–	2	
Rated voltage Us	V	–	–	–	–	–	–	–	–	– 24

(1) See sub-base compatibility, page 4/26.

(2) 1 channel for TSX CTZ1A, 2 for TSX CTZ2A, 8 for TSX 37-22

(3) CJC: Cold Junction Compensation

(4) Positive: U < 2.4 V 0L, U > 3.9 V 1L; Negative: U < 2.4 V 1L, U > 3.9 V 0L

(5) Add standard BG for ABE-7CPA13

Calculation curves to determine the cable and its length according to the current (1)

8-channel sub-base

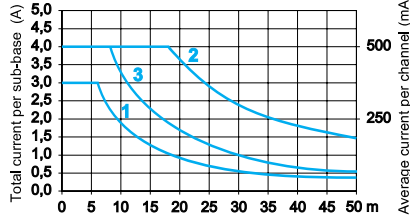

12-channel sub-base

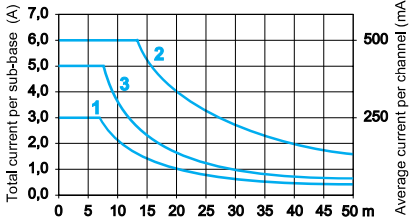

16-channel sub-base

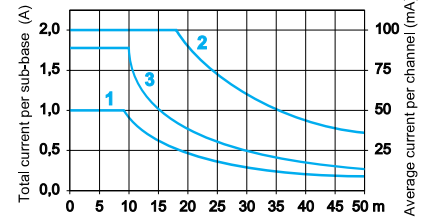

1 TSX CDP●●2 and ABF-H20H●●0 cables with 0.08 mm² c.s.a. (AWG 28).
 2 TSX CDP●●3 cables with 0.34 mm² c.s.a. (AWG 22).

3 Cables with 0.13 mm² c.s.a. (AWG 26).

Temperature derating curves for sub-bases and removable relays (2)

ABE-7R●●S111 1, ABE-7R1●●S212 2

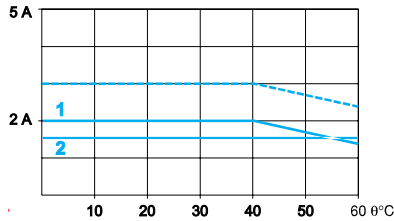

ABE-7P16T214

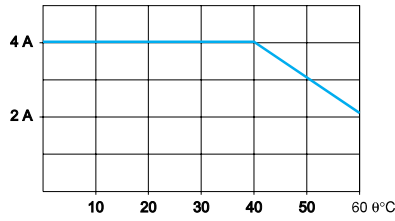

ABE-7P16T215, ABE-7P16T23●

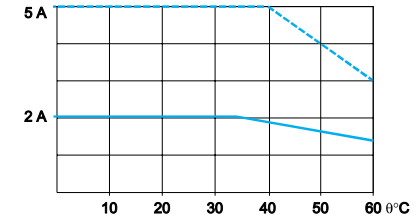

ABE-7●16T21● 1, ABE-7P16T334 2

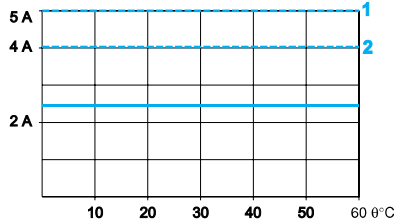

ABE-7●16T332, ABE-7P16T318

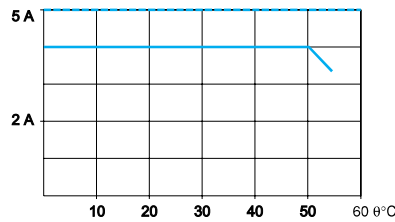

ABE-7●16T330

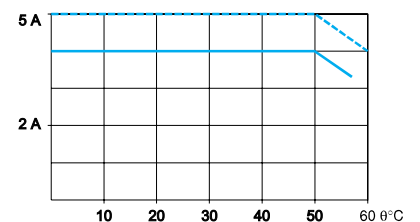

ABE-7R16T370

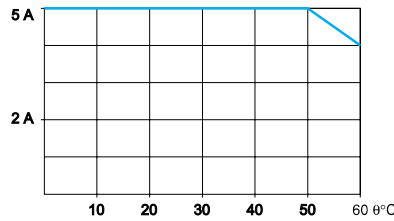

ABS-7SC1B

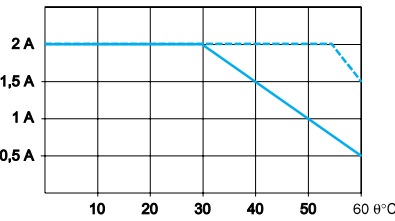

ABE-7SA2M

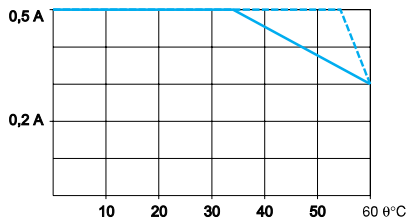

ABS-7SC3BA

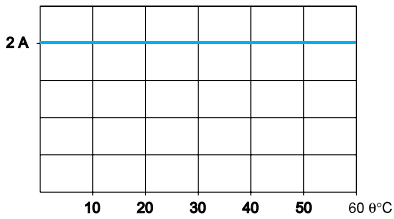

ABS-7SC2E (1) + ABS-7SC3E (2)

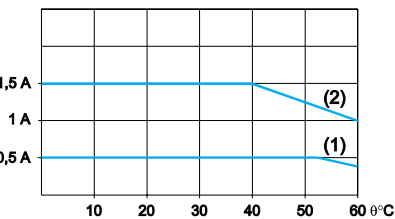

ABS-7SA3M

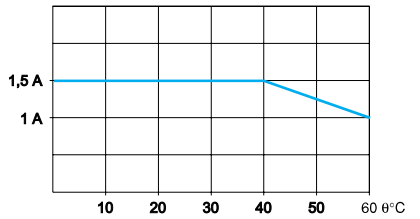

———— 100 % of channels used
 - - - - 50 % of channels

(1) The curves are given for a voltage drop of 1 V in the cable. For n volts tolerance, multiply the length determined from the graph by n.
 (2) There is no derating for ABE-7S08S2B1, ABE-7S●●S2B0, ABE-7S16S2B2 output sub-bases, or for ABS-7EC●●● and ABE-7EA●●● solid state input relays.

Presentation, compatibility:
 pages 4/8 to 4/23

References :
 pages 4/36 to 4/49

Dimensions, schemes :
 pages 4/52 to 4/63

Electrical durability (in millions of operating cycles) (conforming to IEC 60947-5-1)

ABE-7R●●S111
d.c. loads
DC12 curves (1)

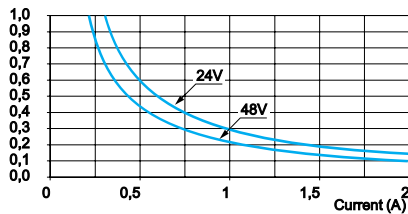

ABE-7R●●S2●●, ABR-7S2● (6), ABE-7R16T2●●

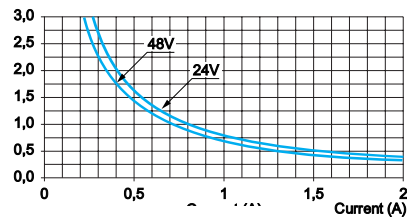

DC13 curves (2)

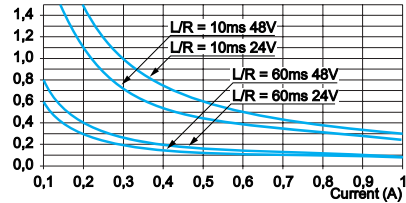
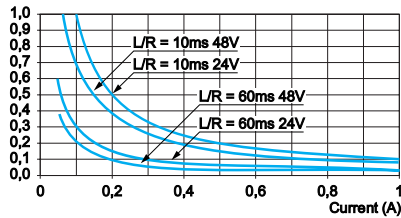

a.c. loads
AC12 curves (3)

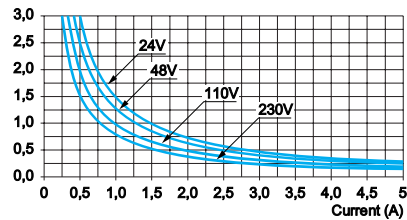
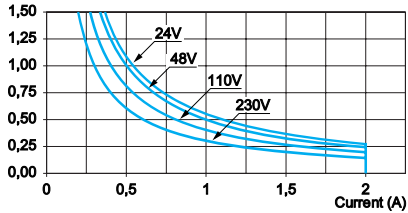

AC14 curves (4)

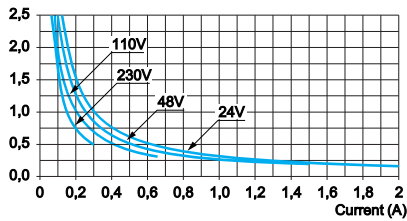
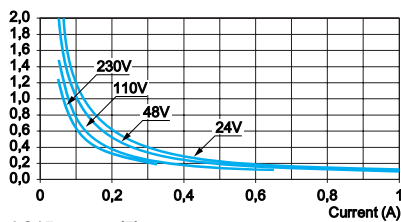

AC15 curves (5)

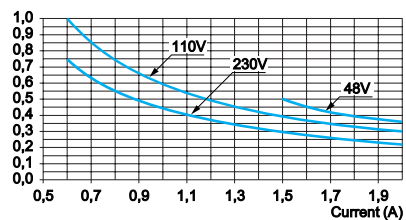
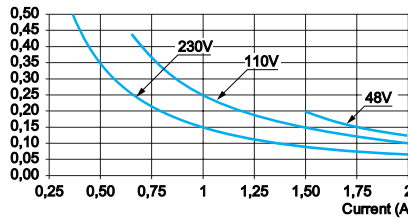

- (1) DC12: control of resistive loads and of solid state loads isolated by optocoupler, $I/R \leq 1$ ms
- (2) DC13: control of electromagnets, $L/R \leq 2 \times (U_e \times I_e)$ in ms, U_e : rated operational voltage, I_e : rated operational current (with a protective diode on the load, DC12 curves must be used with a coefficient of 0.9 applied to the number in millions of operating cycles).
- (3) AC12: control of resistive loads and of solid state loads isolated by optocoupler, $\cos \varphi \geq 0.9$
- (4) AC14: control of small electromagnetic loads ≤ 72 VA, make: $\cos \varphi = 0.3$, break: $\cos \varphi = 0.3$
- (5) AC15: control of electromagnetic loads > 72 VA, make: $\cos \varphi = 0.7$, break: $\cos \varphi = 0.4$
- (6) Multiply all durability values by 0.75 for ABS-7S23 and for ABR-7S37

Electrical durability (in millions of operating cycles) (conforming to IEC 60947-5-1)

ABR-7S3● (1), ABE-7P16T3●● and ABE-7R16T3●●

d.c. loads

DC12 curves (2)

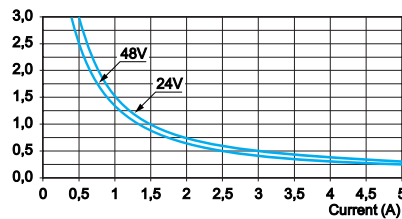

DC13 curves (3)

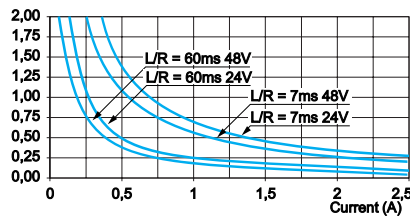

a.c. loads

AC12 curves (4)

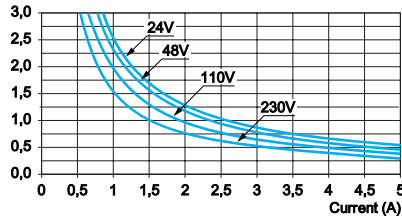

AC14 curves (5)

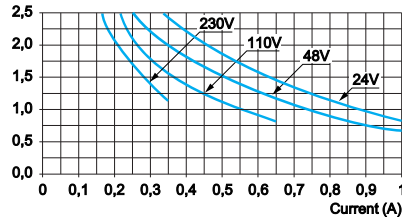

AC15 curves (6)

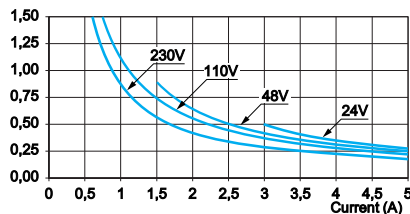

(1) Multiply all the durability values by 0.75 for ABS-7S23 and for ABR-7S37

(2) DC12: control of resistive loads and of solid state loads isolated by optocoupler, $I/R \leq 1$ ms

(3) DC13: control of electromagnets, $L/R \leq 2 \times (U_e \times I_e)$ in ms, U_e : rated operational voltage, I_e : rated operational current (with a protective diode on the load, DC12 curves must be used with a coefficient of 0.9 applied to the number in millions of operating cycles).

(4) AC12: control of resistive loads and of solid state loads isolated by optocoupler, $\cos \varphi \geq 0.9$

(5) AC14: control of small electromagnetic loads ≤ 72 VA, make: $\cos \varphi = 0.3$, break: $\cos \varphi = 0.3$

(6) AC15: control of electromagnetic loads > 72 VA, make: $\cos \varphi = 0.7$, break: $\cos \varphi = 0.4$

Electrical durability (in millions of operating cycles) (conforming to IEC 60947-5-1)

ABE-7R16●111
d.c. loads
DC12 curves (1)

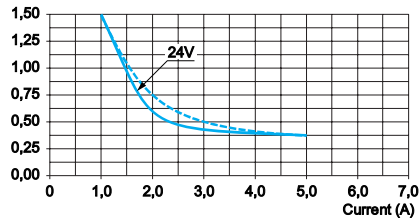

ABE-7R08S216

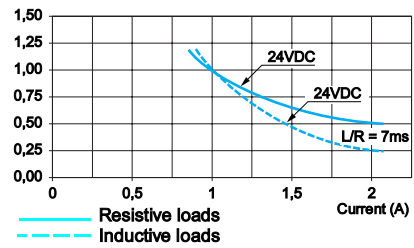

DC13 curves (2)

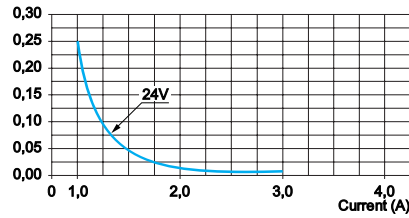

a.c. loads
AC12 curves (3)

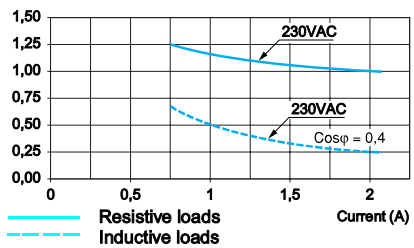
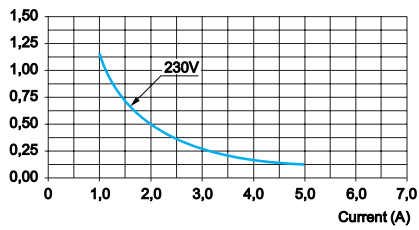

AC15 curves x(4)

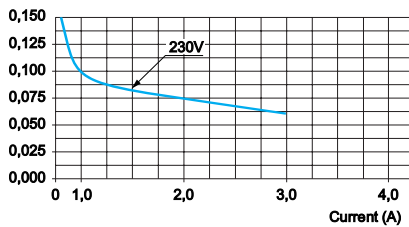

(1) DC12: control of resistive loads and of solid state loads isolated by optocoupler, $I/R \leq 1$ ms
 (2) DC13: control of electromagnets, $L/R \leq 2 \times (U_e \times I_e)$ in ms, U_e : rated operational voltage, I_e : rated operational current (with a protective diode on the load, DC12 curves must be used with a coefficient of 0.9 applied to the number in millions of operating cycles).
 (3) AC12: control of resistive loads and of solid state loads isolated by optocoupler, $\cos \varphi \geq 0.9$
 (4) AC15: Control of electromagnetic loads > 72 VA, make: $\cos \varphi = 0.7$, break: $\cos \varphi = 0.4$



Connection interfaces

Telefast® 2 pre-wired system
Passive connection sub-bases

Passive connection sub-bases for discrete signals



ABE-7H20E...

"Low cost" sub-bases

Function	No. of channels	No. of terminals per channel	For PLCs on row number	For PLCs	Length of PLC connection cable m	Type of connection	Reference	Weight kg		
Input or Output	16	1	2	Modicon TSX Micro/Premium	1	Screw	ABE-7H20E100	0.330		
					2	Screw	ABE-7H20E200	0.410		
					3	Screw	ABE-7H20E300	0.480		
						Siemens S7	1.5	Screw	ABE-7H32E150	0.360
							3	Screw	ABE-7H32E300	0.460

"Miniature" sub-bases

Function	No. of channels	No. of terminals per channel	LED per channel	Polarity distribution	Type of connection	Reference	Weight kg	
Input or Output	16	1	1	No	No	Screw	ABE-7H16C10	0.160
				Yes	No	Screw	ABE-7H16C11	0.160
				Yes	0 or 24 V	Screw	ABE-7H16C21	0.205
		3	3	Yes	0 and 24 V	Screw	ABE-7H16C31	0.260
Input and Output(1)	16	1	1	Yes	No	Screw	ABE-7H16CM11	0.160
							2	2

(1) 8 I + 8 Q: these products have 2 commons connections which enable inputs and outputs to be connected to the same sub-base at the same time.

Connection interfaces

Telefast® 2 pre-wired system
Passive connection sub-bases



816464
ABE-7H16R50



816465
ABE-7H16R31



816466
ABE-7H16S43

Passive connection sub-bases for discrete signals (continued)

Function	No. of channels	No. of terminals per channel	No. of rows	LED per channel	Polarity	Isolator (I) distribution Fuse (F) per channel	Type of connection	Reference	Weight kg
Input or Output	8	1	1	No	No	–	Screw	ABE-7H08R10	0.187
				Yes	No	–	Screw	ABE-7H08R11	0.187
	2	2	2	Yes	0 or 24 V	–	Screw	ABE-7H08R21	0.218
						I	Screw	ABE-7H08S21	0.245
				No	No	–	Screw	ABE-7H12R10	0.274
						–	Screw	ABE-7H12R11	0.274
	2	2	2	No	0 or 24 V	–	Screw	ABE-7H12R20	0.300
						–	Screw	ABE-7H12R21	0.300
				Yes	0 or 24 V	–	Screw	ABE-7H12S21	0.375
						I	Screw	ABE-7H12S21	0.375
				No	No	–	Screw	ABE-7H16R10	0.274
						–	Screw	ABE-7H16R11	0.274
No	No	–	Spring	ABE-7H16R11E	0.274				
		–	Screw	ABE-7H16R50	0.196				
No	No	–	Spring	ABE-7H16R50E	0.196				
		–	Screw	ABE-7H16R20	0.300				
Yes	0 or 24 V	–	Screw	ABE-7H16R21	0.300				
		–	Spring	ABE-7H16R21E	0.300				
No	No	–	Screw	ABE-7H16S21	0.375				
		–	Spring	ABE-7H16S21E	0.375				
No	0 and 24 V	–	Screw	ABE-7H16R30	0.346				
		–	Screw	ABE-7H16R31	0.346				
Type 2 Input (1)	16	2	2	Yes	0 and 24 V	–	Screw	ABE-7H16R23	0.320
Input	16	2	1	Yes	24 V	I, F (2)	Screw	ABE-7H16S43	0.640
Output	16	2	1	Yes	0 V	I, F (2)	Screw	ABE-7H16F43	0.640

(1) For Modicon TSX Micro, Premium and Numerical Controller NUM 1020/1060.
(2) With LED to indicate blown fuse.

Connection interfaces

Telefast® 2 pre-wired system
Connection sub-bases with soldered relays and plug-in terminal blocks

816457



ABE-7S16E2●●

Sub-bases with soldered solid state inputs, plug-in terminal blocks

Number of channels	No. of terminals per channel	Isolation PLC/application	Voltage V	Type of connection	Reference	Weight kg
16	2	Yes	--- 24	Screw	ABE-7S16E2B1	0.370
				Spring	ABE-7S16E2B1E	0.370
			--- 48	Screw	ABE-7S16E2E1	0.370
				Spring	ABE-7S16E2E1E	0.370
			~ 48	Screw	ABE-7S16E2E0	0.386
				Spring	ABE-7S16E2E0E	0.386
			~ 110	Screw	ABE-7S16E2F0	0.397
				Spring	ABE-7S16E2F0E	0.397
			~ 230	Screw	ABE-7S16E2M0	0.407
				Spring	ABE-7S16E2M0E	0.407

Sub-bases with soldered solid state outputs, plug-in terminal blocks

No. of channels	Isolation PLC/application	Output voltage V	Output current A	Fault detection signal (1)	Type of connection	Reference	Weight kg
8	No	--- 24	0.5	Yes (2)	Screw	ABE-7S08S2B0	0.252
					Spring	ABE-7S08S2B0E	0.252
			2	Yes (2)	Screw	ABE-7S08S2B1	0.448
					Spring	ABE-7S08S2B1E	0.448
16	No	--- 24	0.5	Yes (2)	Screw	ABE-7S16S2B0	0.405
					Spring	ABE-7S16S2B0E	0.405
			No		Screw	ABE-7S16S1B2	0.400
					Spring	ABE-7S16S1B2E	0.400

Sub-bases with soldered electromechanical relays, plug-in terminal blocks

No. of channels	Relay width mm	No. of contacts	Output current A	Polarity distribution/application	Type of connection	Reference	Weight kg	
8	5	1 "N/O"	2	Contact common per group of 4 channels	Screw	ABE-7R08S111	0.244	
					Spring	ABE-7R08S111E	0.244	
		Bistable	2	Volt-free	Screw	ABE-7R08S216	0.250	
					Spring	ABE-7R08S216E	0.250	
		10	1 "N/O"	5	Volt-free	Screw	ABE-7R08S210	0.352
						Spring	ABE-7R08S210E	0.352
16	5	1 "N/O"	2	Contact common per group of 8 channels	Screw	ABE-7R16S11	0.352	
					Spring	ABE-7R16S111E	0.352	
	10	1 "N/O"	5	Volt-free	Screw	ABE-7R16S210	0.547	
					Spring	ABE-7R16S210E	0.547	
	Common per group of 8 chan. on both poles				Screw	ABE-7R16S212	0.547	
					Spring	ABE-7R16S212E	0.547	

(1) A fault on a sub-base output Qn will set PLC output Qn to safety mode which will be detected by the PLC.

(2) Can only be used with modules with protected outputs.

Presentation, compatibility:
pages 4/8 to 4/23

Characteristics:
pages 4/26 to 4/35

Dimensions, schemes:
pages 4/52 to 4/63

Connection interfaces

Telefast® 2 pre-wired system
Plug-in relay sub-bases

816489



ABE-7R16T210

Sub-bases for plug-in solid state input relays (1)

No. of channels	Terminals/channel	For relay type	Isolation PLC/application	Input connection	Type of connection	Reference	Weight kg
16	2	ABS-7E ABR-7 ABS-7S33E	Yes	Volt-free	Screw	ABE-7P16F310	0.850
					Spring	ABE-7P16F310E	0.850
					Polarity distribution	Screw	ABE-7P16F312

816471



ABE-7R16M111

Output sub-bases, equipped with plug-in electromechanical relays (2)

No. of channels	Relay width mm	Type of relay	No. and type of contacts	Polarity distribution/application	Reference	Weight kg
16	5	ABR-7S11	1 N/O	Contact common per group of 4 channels	ABE-7R16T111	0.600
				Contact common per group of 4 output channels + 2 input common terminals	ABE-7R16M111 (3)	0.600
10	ABR-7S21	1 N/O	1 N/O	Volt-free	ABE-7R16T210	0.735
				Common on both poles (4)	ABE-7R16T212	0.730
				ABR-7S23	1 C/O	Contact common (4)
12	ABR-7S33	1 C/O	1 C/O	Volt-free	ABE-7R16T230	0.775
				Volt-free	ABE-7R16T330	1.300
				Common on both poles (5)	ABE-7R16T332	1.200
	ABR-7S37	2 C/O		Volt-free	ABE-7R16T370	1.300

(1) Not equipped with relays.

(2) Both technologies (electromechanical and solid state) may be combined on the same sub-base.

(3) 2 connection methods are available, enabling inputs and outputs to be connected to the same sub-base at the same time.

(4) Per group of 8 channels.

(5) Per group of 4 channels.

Connection interfaces

Telefast® 2 pre-wired system
Plug-in relay sub-bases

Sub-bases for solid state and/or electromechanical output relays, plug-in (1)

No. of Relay chan- nels	width mm	For relay type	Isolator per channel	Fuse per channel	Polarity distribution/ application	Type of connection	Reference	Weight kg		
16	5	ABR-7S11 ABS-7SC1B	No	No	Contact common per group of 4 channels		ABE-7P16T111	0.550		
							ABE-7P16M111 (2)	0.550		
10		ABR-7S2● ABS-7SA2● ABS-7SC2● ABE-7ACC20	No	No	Volt-free	Screw	ABE-7P16T210 (3)	0.615		
							ABE-7P16T230 (3)	0.655		
						Spring	ABE-7P16T230E (3)	0.655		
					Yes	Volt-free	Screw	ABE-7P16T214	0.675	
					No	Common on both poles (4)	Screw	ABE-7P16T212	0.615	
					Yes	Common on both poles (4)	Screw	ABE-7P16T215	0.670	
8	12	ABR-7S33 ABS-7SA3● ABS-7SC3●● ABE-7ACC21	No	No	Volt-free	Screw	ABE-7P08T330	0.450		
						Spring	ABE-7P08T330E	0.450		
16	12	ABR-7S33 ABS-7SA3● ABS-7SC3●● ABE-7ACC21	No	No	Volt-free	Screw	ABE-7P16T330	0.900		
						Spring	ABE-7P16T330E	0.900		
							ABE-7P16T332	0.900		
						Common on both poles (5)	Screw	ABE-7P16T334	0.900	
					Yes	Yes	Common on both poles (5)	Screw	ABE-7P16T318	1.000
							Spring	ABE-7P16T318E	1.000	

816473



ABE-7P16T200

- (1) Not equipped with relays
(2) 2 connection methods are available, enabling inputs and outputs to be connected to the same sub-base at the same time.
(3) With relay ABR-7S21 for sub-base ABE-7P16T210, with relay ABR-7S23 for sub-base ABE-7P16T230.
(4) Per group of 8 channels.
(5) Per group of 4 channels.

Presentation, compatibility:
pages 4/8 to 4/23

Characteristics:
pages 4/26 to 4/35

Dimensions, schemes:
pages 4/52 to 4/63

Connection interfaces

Telefast® 2 pre-wired system
Plug-in relays

Plug-in solid state relays (Order in multiples of 4)

Relay width mm	Func-tions	Input circuit		Output circuit		Unit reference	Weight kg	
		Current	Nominal voltage V	Current (1) A	Nominal voltage V			
5	Output	---	24	2	--- 24	ABS-7SC1B	0.010	
10	Output	---	24	0.5	--- 5...48	ABS-7SC2E	0.016	
					~ 24...240	ABS-7SA2M	0.016	
12	Input	---	5 TTL		--- 24	ABS-7EC3AL	0.014	
			24 Type 2	-	--- 24	ABS-7EC3B2	0.014	
			48 Type 2	-	--- 24	ABS-7EC3E2	0.014	
			~ 50 Hz	48	-	--- 24	ABS-7EA3E5	0.014
			~ 60 Hz	110...130	-	--- 24	ABS-7EA3F5	0.014
			~ 50 Hz	230...240	-	--- 24	ABS-7EA3M5	0.014
Output	---	24		2 Self-protected	--- 24	ABS-7SC3BA	0.016	
				1.5	--- 5...48	ABS-7SC3E	0.016	
				1.5	~ 24...240	ABS-7SA3MA	0.016	

Plug-in electromechanical relays

Relay width mm	Control voltage V	Output current (1) A (lth)	No. of contacts	Order in multiples of	Unit reference	Weight kg
5	--- 24	5	1 N/O	4	ABR-7S11	0.005
10	--- 24	5	1 N/O	4	ABR-7S21	0.008
			1 C/O	4	ABR-7S23	0.008
12	--- 24	10	1 C/O	4	ABR-7S33	0.017
		8	2 C/O	4	ABR-7S37	0.017
		--- 48	8	1 C/O	4	ABR-7S33E

Accessory

Description	Reference	Weight kg
Extractor for 5 mm miniature relays	ABE-7ACC12	0.010

(1) See characteristics table for specifications of relays in the sub-bases



ABS-7SC1B



ABR-7S21



ABR-7S33

Connection interfaces

Telefast® 2 pre-wired system
Connection sub-bases for counter and analogue channels

816477



ABE-7CPA02

Connection sub-bases for counter and analogue channels (1)

Functions	For PLCs	Compatible modules	Type of connection Telefast 2 side	Type of connection	Reference	Weight kg
Counting and analogue	Modicon TSX Micro (1)	Integrated analogue and counter TSX 37.22 TSX CTZ●A	15-way SUB-D	Screw	ABE-7CPA01 (2)	0.300
Counting Axis control Position control	Modicon TSX Premium (1)	TSX CTY●A TSX CAY●1	15-way SUB-D	Screw	ABE-7CPA01 (2)	0.300
Parallel output absolute encoder connection	Modicon TSX Premium	TSX CTY●A TSX CAY●1	15-way SUB-D	Screw	ABE-7CPA11	0.330
Distribution of 16 thermocouples	Modicon TSX Premium	TSX AEY1614	25-way SUB-D	Screw	ABE-7CPA12	0.300
Passive distribution of 8 channels on screw terminal block with shielding continuity	TSX 47/107 Modicon TSX Premium (1)	TSX AEM8●1 TSX AEM16●● TSX ASY810 TSX AEY1600 TSX A●Y800	25-way SUB-D	Screw	ABE-7CPA02	0.290
Distribution of 4 analogue output channels	Modicon TSX Premium (1)	TSX ASY410 TSX AEY420	25-way SUB-D	Screw	ABE-7CPA21	0.210
Distribution and supply of 8 analogue channels with limitation of each current loop	TSX 47/107 Modicon TSX Premium (1)	TSX AEM8●1 TSX AEM16●● TSX AEY800 TSX AEY1600	25-way SUB-D	Screw	ABE-7CPA03	0.330
Distribution and supply of 8 analogue input channels isolated from each other with 25 mA/channel limiter	Modicon TSX Premium (1)	TSX AEY810	25-way SUB-D	Screw	ABE-7CPA31	0.410
				Spring	ABE-7CPA31E	0.410
Safety	Modicon TSX Premium (1)	TSX PAY2●2	25-way SUB-D	Screw	ABE-7CPA13	0.290

(1) For other PLCs, see compatibility tables on pages 4/19 to 4/23.

(2) See installation procedure in TSX 37E manual

Presentation, compatibility:
pages 4/8 to 4/23

Characteristics:
pages 4/26 to 4/33

Dimensions, schemes:
pages 4/52 to 4/63

Connection interfaces

Telefast® 2 pre-wired system
Accessories for connection sub-bases

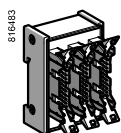

ABE-7ACC02

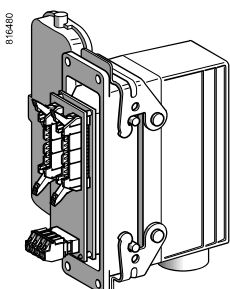

ABE-7ACC80 + ABE-7ACC81

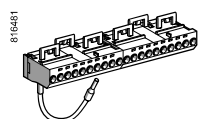

ABE-7BV20

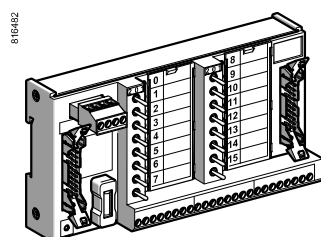

ABE-7TES160

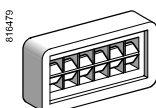

AR1-SB3

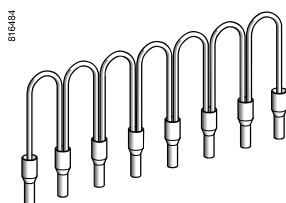

ABF-C08Rxxx

Software

Description	Operating system	Reference	Weight kg
Software for client label marking	Under Windows version 3.1 or 95	ABE-7LOGV10	0.350
Pack of 25 pre-cut label sheets (160 labels)	–	ABE-7LOGF25	0.200

Accessories

Description	No. of channels	Characteristics	Order in multiples of	Unit reference	Weight kg
Kit for fixing on solid plate	–	–	10	ABE-7ACC01	0.008
Splitter sub-base	–	16 as 2 x 8 channels	1	ABE-7ACC02	0.075
Redundant output sub-base	–	16 as 2 x 16 channels	1	ABE-7ACC10	0.075
Redundant input sub-base	–	16 as 2 x 16 channels	1	ABE-7ACC11	0.075
Removable continuity blocks	–	10 mm wide	4	ABE-7ACC20	0.007
	–	12 mm wide	4	ABE-7ACC21	0.010
Locating device for removable terminal block	–	–	100	ABE-7ACC30	0.100
Enclosure feedthrough with industrial connector	32	40-way	1	ABE-7ACC80	0.300
Plug-in 40-way male connector	32	For mounting on ABE-7ACC80	1	ABE-7ACC81	0.370
Enclosure feedthrough with CNOMO M23 connector (1 x 20-way HE 10 connector, PLC end)	16	19-way	1	ABE-7ACC82	0.150
	8 and 12	19-way	1	ABE-7ACC83	0.150
Impedance adaptor for Type 2 compatibility	–	Used with ABE-7ACC82 and ABE-7ACC83	1	ABE-7ACC85	0.012
IP 65 cable gland	–	For 3 cables	1	ABE-7ACC84	0.300
Additional snap-on terminal blocks (shunted terminals)	8	10 screw terminals	5	ABE-7BV10	0.030
		10 spring terminals	5	ABE-7BV10E	0.030
	16	20 screw terminals	5	ABE-7BV20	0.060
		20 spring terminals	5	ABE-7BV20E	0.060
I/O simulator sub-base	16	Display, forcing inhibition, continuity	1	ABE-7TES160	0.350
Adhesive label holder	–	For 6 characters	50	AR1-SB3	0.001
Fast blow fuses	–	0.125 A	10	ABE-7FU012	0.010
5 x 20, 250 V, UL		0.5 A	10	ABE-7FU050	0.010
		1 A	10	ABE-7FU100	0.010
		2 A	10	ABE-7FU200	0.010
		4 A	10	ABE-7FU400	0.010
		6.3 A	10	ABE-7FU630	0.010

"Flexible commoning links" accessories

Description	For common	Colour	Distance between cable ends cm	Reference	Weight kg	
Flexible commoning links	Coil	White	12	ABF-C08R12W	0.020	
			2	ABF-C08R02W	0.010	
	~	Red	12	ABF-C08R12R	0.020	
			2	ABF-C08R02R	0.010	
	Modularity 8 x 1 mm ²	---	Blue	12	ABF-C08R12B	0.020
				2	ABF-C08R02B	0.010

Presentation, compatibility:
pages 4/8 to 4/25

Characteristics:
pages 4/26 to 4/33

Dimensions, schemes:
pages 4/52 to 4/63

Connection interfaces

Telefast® 2 pre-wired system
 Connection sub-bases for counter and analogue channels
 Connection cables for Modicon TSX Micro and Premium PLCs

Connection cables for Modicon TSX Micro and Premium PLCs (1)

Functions	Compatible TSX modules	Type of connection		Gauge	Cross-section	Length	Reference	Weight		
		PLC end	Telefast 2 end							
				AWG	mm ²	m				
Discrete I/O	DMZ●●DTK DEZ●●D2K DSZ●●T2K DEY●●D2K DSY●●T2K DEY●●16FK	20-way HE 10	20-way HE 10	28	0.080	1	ABF-H20H100 (2)	0.080		
				2	ABF-H20H200 (2)	0.140				
				3	ABF-H20H300 (2)	0.210				
				22	0.324	0.5	TSX CDP 053	0.085		
						1	TSX CDP 103	0.150		
						2	TSX CDP 203	0.280		
						3	TSX CDP 303	0.410		
						5	TSX CDP 503	0.670		
			Universal	Bare wires	20-way HE 10	22	0.324	3	TSX CDP 301	0.400
								5	TSX CDP 501	0.660
Analogue	AEY●●	25-way SUB-D	25-way SUB-D	24	0.205	3	TSX CAP 030	0.670		
	Universal	Bare wires	25-way SUB-D	24	0.205	2	ABF-F25S200 (4)	0.300		
	ASY410	TSX BLY01	25-way SUB-D	24	0.205	2	ABF-Y25S200	0.375		
Analogue and counter Counter	3722●● CTY●A	15-way SUB-D	15-way SUB-D	24	0.205	2.5	TSX CCP S15	0.220		
Counter	CTZ●A	15-way SUB-D (3)	15-way SUB-D	24	0.205	2.5	TSX CCP H15	0.220		
Axis control	CAY●1	9-way SUB-D	9-way SUB-D	24	0.205	2	TSX CXP 213	0.270		
						6	TSX CXP 613	0.580		

Accessories

Description	Gauge	Cross-section	Length	Sold in lots of	Unit reference	Weight
						kg
Rolled ribbon cable	28	0.08	20	1	ABF-C20R200	1.310
20-way HE 10 connector	-	-	-	2	ABC-6HE20F	0.008

(1) Standard cables, see page 4/42.

(2) Specific lengths available: 4, 5, 8, 10, 15, 20, 25 and 30 m (please consult your Regional Sales Office).

(3) High density.

(4) See colour coded marking on page 4/62.

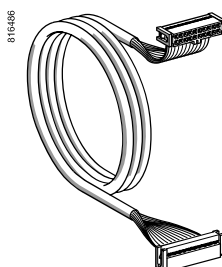

ABF-H20H200

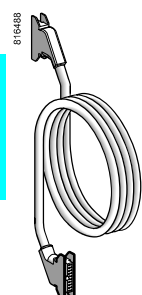

TSX-CDP●●3

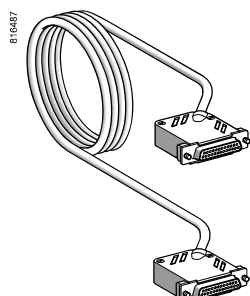

TSX-CCPS15



ABC-6HE20F

Connection interfaces

Telefast® 2 pre-wired system
Terminal blocks, cabled connectors and connection cables
for TSX 47 to 107 PLCs

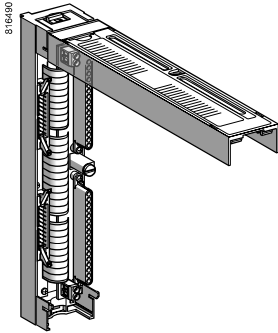

TSX BLK 01

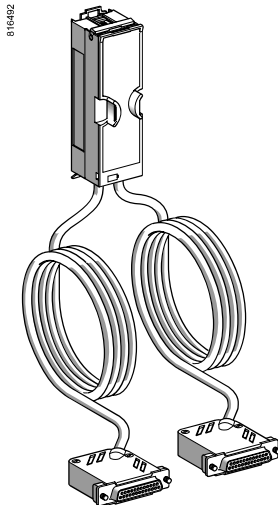

ABF-B50S 001

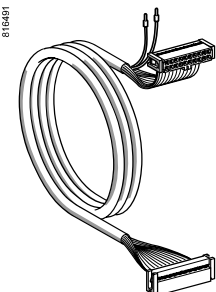

ABF-H20H 001

Connection terminal blocks (with LED display of I/O)

Number of channels	Type of discrete interface	Type of connection	Reference	Weight kg
32	TSX DET 32●2 inputs	2 x 20-way male HE 10 connectors	TSX BLK 71	0.200
	TSX DST 32●2 outputs	2 x 20-way male HE 10 connectors	TSX BLK 91	0.200
24	TSX DST 24●2 outputs	1 x 34-way male HE 10 connector	TSX BLK 81 (1)	0.200

Cabled connectors for TSX AEM●● and TSX DST16●● modules

Type of signal	Type of connection PLC end	Telefast end	Gauge AWG	Cross-section mm ²	Length m	Modularity	Reference	Weight kg
Analogue	Terminal block	2 x 25-way SUB-D	24	0.22	2	16	ABF-B50S201	0.510
		BLK 4	24	0.22	3	16	ABF-B50S301	0.760
	included	1 x 25-way SUB-D	24	0.22	2	8	ABF-B25S201	0.500
		BLK 4	24	0.22	3	8	ABF-B25S301	0.670

Connection cables

Type of signal	Type of connection PLC end	Telefast end	Gauge AWG	Cross-section mm ²	Length m	Modularity	Reference	Weight kg
Discrete I/O	1 x 34-way HE 10 on BLK 81	1 x 34-way HE 10	28	0.08	1	24	ABF-H34H100 (1)	0.055
		HE 10	28	0.08	2	24	ABF-H34H200 (1)	0.100
		HE 10	28	0.08	3	24	ABF-H34H300 (1)	0.145
	1 x 20-way HE 10 with power on BLK 71/91	1 x 20-way HE 10	28	0.08	1.5	16	ABF-H20H151	0.110
		HE 10	28	0.08	2	16	ABF-H20H201	0.140
		HE 10	28	0.08	3	16	ABF-H20H301	0.210
					5	16	ABF-H20H501	0.350
Analogue	1 x 25-way SUB-D on TSX AEM 1613	1 x 25-way SUB-D	24	0.22	3	16	ABF-S25S301	0.620

Splitter sub-base for TSX DST 24●2

Splitter sub-base, 24 channels, 3 x 8 channels	ABE-7ACC03	0.115
(1) Splitter sub-base ABE-7ACC03 must be used.		

Correspondence tables

ABF-S25S30●

ABF-B25S01

ABF-B50S01

Male SUB-D pins	No. of cable pairs	Female SUB-D pins
1-2	1	1-2
3-14	2	3-14
15-16	3	15-16
4-5	4	4-5
6-17	5	6-17
18-19	6	18-19
7-8	7	7-8
9-20	8	9-20
21-22	9	21-22
10-11	10	10-11
12-23	11	12-23
24-25	12	24-25
13	13	13

25-way SUB-D		TSX BLK4		25-way SUB-D	
Term. no.	Channels	Term. blk.		Channels	Term. no.
1-2	V0+	8	1	V4+	7-8
14	V0-	7	2	V4-	20
	±	6	3	±	
15-16	V1+	5	4	V5+	21-22
3	V1-	4	5	V5-	9
	±	3	6	±	
4-5	V2+	2	7	V6+	10-11
17	V2-	1	8	V6-	23
	±				
	±				
18-19	V3+	8	1	V7+	24-25
6	V3-	7	2	V7-	12-13
	±	6	3		
		5	4		
		4	5		
		3	6		
		2	7		
		1	8		

25-way SUB-D ①		TSX BLK4		25-way SUB-D ②	
Term. no.		Term. blk.		Term. no.	
1-2		8	1	1-2	
14		7	2	14	
15-16		6	3	15-16	
3		5	4	3	
4-5		4	5	4-5	
17		3	6	17	
18-19		2	7	18-19	
6		1	8	6	
7-8		8	1	7-8	
20		7	2	20	
21-22		6	3	21-22	
9		5	4	9	
10-11		4	5	10-11	
23		3	6	23	
24-25		2	7	24-25	
12-13		1	8	12-13	

Connection interfaces

Telefast® 2 pre-wired system
Cables and sub-bases for NUM numerical control



ABE-7ACC04

Splitter sub-bases for NUM numerical control

Description	For NUM processor unit	Type of signal	Type of connection		Reference	Weight kg
			Processor unit end	Telefast end		
Splitter sub-bases	1020	32 channels (input)	37-way male SUB-D	2 x 20-way HE 10	ABE-7ACC04	0.100
	1050			3 x 20-way HE 10		
	1060	24 channels (output)	37-way female SUB-D	3 x 20-way HE 10	ABE-7ACC05	0.105

Example of connection

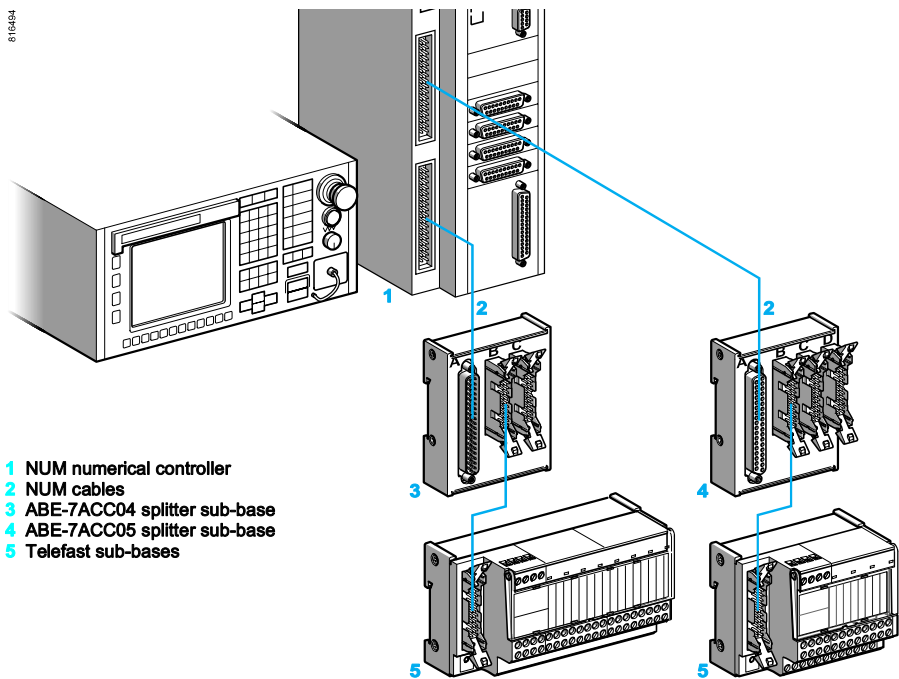

- 1 NUM numerical controller
- 2 NUM cables
- 3 ABE-7ACC04 splitter sub-base
- 4 ABE-7ACC05 splitter sub-base
- 5 Telefast sub-bases

ABE-7ACC04

20-way HE 10 B		SUB-D A		20-way HE 10 C	
Terminal no.	Channels	Terminal blk.	Channels	Terminal no.	Channels
1	0	1	29	16	1
2	1	20	11	17	2
3	2	2	30	18	3
4	3	21	12	19	4
5	4	3	31	20	5
6	5	22	13	21	6
7	6	4	32	22	7
8	7	23	14	23	8
9	8	24	15	24	9
10	9	6	34	25	10
11	10	25	16	26	11
12	11	7	35	27	12
13	12	26	17	28	13
14	13	8	36	29	14
15	14	27	18	30	15
16	15	9	37	31	16
17	24 V	10	10	24 V	17
18	0 V	5	28	0 V	18
19	NC	19	33	NC	19
20	0 V			0 V	20

ABE-7ACC05

20-way HE 10 B		SUB-D A		20-way HE 10 C	
Terminal no.	Channels	Terminal blk.	Channels	Terminal no.	Channels
1	0	4	13	8	1
2	1	25	31	9	2
3	2	24	12	10	3
4	3	20	30	11	4
5	4	21	28	12	5
6	5	22	8	13	6
7	6	23	5	14	7
8	7	1	7	15	8
13 to 17-19	24 V	2-10-15-19	24 V	13 to 17-19	24 V
18 to 20	0 V	3-9-14-34	0 V	18-20	0 V
9 to 12	NC		NC	9 to 12	NC
20-way HE 10 D		Terminal blk.			
Terminal no.	Channels	Terminal blk.	Channels	Terminal no.	Channels
1	16	37	18	1	16
2	17	18	17	2	17
3	18	36	16	3	18
4	19	17	35	4	19
5	20	16	32	5	20
6	21	33	31	6	21
7	22	32	30	7	22
8	23	2-10-15-19	24 V	8	23
13 to 17-19	24 V	3-9-14-34	0 V	13 to 17-19	24 V
18 to 20	0 V			18 to 20	0 V
9 to 12	NC			9 to 12	NC

Connection interfaces

Telefast® 2 pre-wired system
Cabled connectors and connection cables for APRIL Series 1000 PLCs

Cabled connectors for APRIL Series 1000 PLCs

Type of signal	Type of connection PLC end	Telefast end	Gauge AWG	Cross-section mm ²	Length m	Modularity	Reference	Weight kg
Inputs and relay outputs	PIN 0100 term. block HE 10 included	2 x 20-way	26	0.13	2	2 x 16	ABF-A32H200	0.450
					3	2 x 16	ABF-A32H300	0.620
0.5 A output	PIN 0100 term. block HE 10 with external power supply	2 x 20-way	22	0.324	1.5	2 x 16	ABF-A32H151	0.650
					3	2 x 16	ABF-A32H301	1.150

Connection cable for APRIL IXA/IRA 1600 module

Type of signal	Type of connection PLC end	Telefast end	Gauge AWG	Cross-section mm ²	Length m	Modularity	Reference	Weight kg
Analogue	1 x 25-way SUB-D	1 x 25-way SUB-D	24	0.22	3	16	ABF-S25S302	0.620

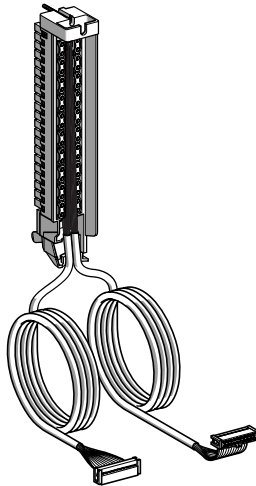

ABF-A32H00

Example of connection

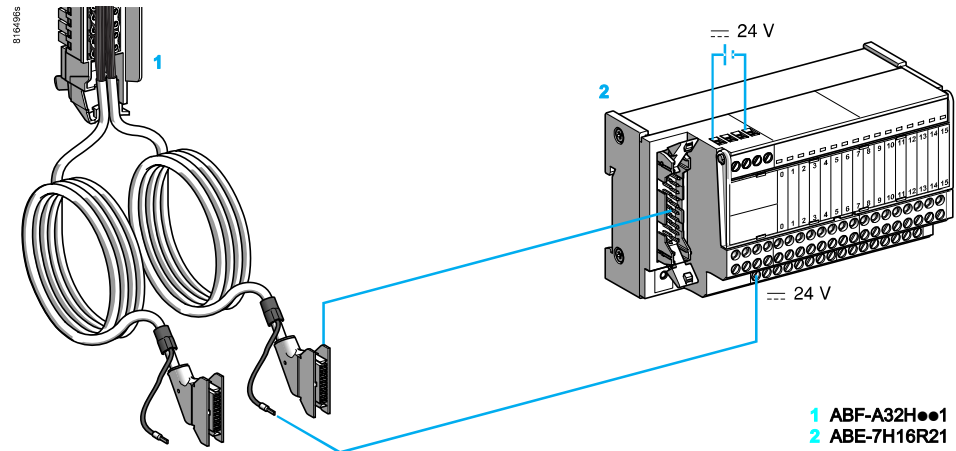

1 ABF-A32H00
2 ABE-7H16R21

Correspondence tables between the PLC terminal block and HE 10 connectors

ABF-A32H00

20-way HE 10 ①		PIN 0100		20-way HE 10 ②	
Terminal no.	Name	Terminal blk.	Name	Terminal no.	
1	Q0	2	Q16	1	
2	Q1	22	Q17	2	
3	Q2	3	Q18	3	
4	Q3	23	Q19	4	
5	Q4	4	Q20	5	
6	Q5	24	Q21	6	
7	Q6	5	Q22	7	
8	Q7	25	Q23	8	
9	Q8	7	Q24	9	
10	Q9	27	Q25	10	
11	Q10	8	Q26	11	
12	Q11	28	Q27	12	
13	Q12	9	Q28	13	
14	Q13	29	Q29	14	
15	Q14	10	Q30	15	
16	Q15	30	Q31	16	
17	--- 24 V	1	--- 24 V	17	
18	--- 0 V	21	--- 0 V	18	
19	--- 24 V	6	--- 24 V	19	
20	--- 0 V	26	--- 0 V	20	

ABF-A32H01

20-way HE 10 ①		PIN 0100		20-way HE 10 ②	
Terminal no.	Name	Terminal blk.	Name	Terminal no.	
1	Q0	2	Q16	1	
2	Q1	22	Q17	2	
3	Q2	3	Q18	3	
4	Q3	23	Q19	4	
5	Q4	4	Q20	5	
6	Q5	24	Q21	6	
7	Q6	5	Q22	7	
8	Q7	25	Q23	8	
9	Q8	7	Q24	9	
10	Q9	27	Q25	10	
11	Q10	8	Q26	11	
12	Q11	28	Q27	12	
13	Q12	9	Q28	13	
14	Q13	29	Q29	14	
15	Q14	10	Q30	15	
16	Q15	30	Q31	16	
17	NC	NC	NC	17	
18	--- 0 V	21/26	31/36	--- 0 V	
19	NC	NC	NC	19	
20	NC	NC	NC	20	
Power supply cable	--- 24 V	1/6	11/16	--- 24 V	Power supply cable

Connection interfaces

Telefast® 2 pre-wired system
Cabled connectors for Modicon 984-A120-Compact PLCs

Cabled connectors for Modicon 984-A120-Compact PLCs

Type of signal	Type of connection	Gauge	Cross-section	Length	Modularity	Reference	Weight
		AWG	mm ²				
Input and relay output	1 x 20-way HE 10	22	0.324	1.5	16	ABF-M16H150	0.300
				3	16	ABF-M16H300	0.550
0.5 A output	2 x 20-way HE 10	22	0.324	1.5	2 x 8	ABF-M16H151	0.500
				3	2 x 8	ABF-M16H301	1.000

Correspondence tables

Cabled connectors for Modicon 984-A120-Compact PLCs
ABF-M16H●●0

20-way HE 10		984-A120 Compact
Terminal no.	Channels	Term. blk.
1	1	3
2	2	4
3	3	5
4	4	6
5	5	7
6	6	8
7	7	9
8	8	10
9	9	14
10	10	15
11	11	16
12	12	17
13	13	18
14	14	19
15	15	20
16	16	21
17	--- 24 V	1
18	--- 0 V	11
19	--- 24 V	12
20	--- 0 V	22

ABF-M16H●●1

20-way HE 10 ①		984-A120 Compact		20-way HE 10 ②	
Terminal no.	Channels	Term. blk.		Channels	Terminal no.
1	1	3	14	9	1
2	2	4	15	10	2
3	3	5	16	11	3
4	4	6	17	12	4
5	5	7	18	13	5
6	6	8	19	14	6
7	7	9	20	15	7
8	8	10	21	16	8
9-10-11-12	NC			NC	9-10-11-12
13-15-17	--- 24 V	1	12	--- 24 V	13-15-17
14-16-19	--- 24 V	2	13	--- 24 V	14-16-19
18-20	--- 0 V	11	22	--- 0 V	18-20

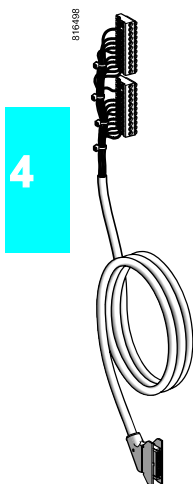

ABF-M16H●●0

Connection interfaces

Telefast® 2 pre-wired system
Cabled connectors for Modicon Quantum PLCs

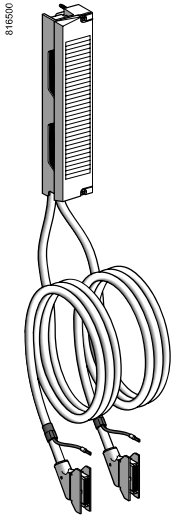

ABF-M32H001

Cabled connectors for Modicon Quantum PLCs

Type of signal	I/O module	Type of connection	Gauge	Cross-section	Length	Modularity	Reference	Weight
			AWG	mm ²				
Input and relay output	-	2 x 20-way HE 10	22	0,324	1,5	2 x 16	ABF-M32H150	0,650
					3	2 x 16	ABF-M32H300	1,150
0,5 A output	-	2 x HE 10 20-way+ ext. supply	22	0,324	1,5	2 x 16	ABF-M32H151	0,650
					3	2 x 16	ABF-M32H301	1,150
Analogue input	140 AVI/ACI 03000	1 x 25-way SUB-D	24	0,22	2	8	ABF-M08S201	0,600
	140 ACI 04000	2 x 25-way SUB-D	24	0,22	2	16	ABF-M16S201	0,620
Analogue output	140 AVO 02000	1 x 25-way SUB-D	24	0,22	2	4	ABF-M04S200	0,450
	140 ACO 02000	1 x 25-way SUB-D	24	0,22	2	4	ABF-M04S201	0,450
	140 ACO 13000	1 x 25-way SUB-D	24	0,22	2	8	ABF-M08S202	0,450

Correspondence tables

Cabled connectors for Modicon Quantum PLCs
ABF-M32H000

20-way HE 10 ①		Quantum		20-way HE 10 ②	
Terminal no.	Channels	Term. blk	Channels	Terminal no.	Terminal no.
1	1	1	21	17	1
2	2	2	22	18	2
3	3	3	23	19	3
4	4	4	24	20	4
5	5	5	25	21	5
6	6	6	26	22	6
7	7	7	27	23	7
8	8	8	28	24	8
9	9	11	31	25	9
10	10	12	32	26	10
11	11	13	33	27	11
12	12	14	34	28	12
13	13	15	35	29	13
14	14	16	36	30	14
15	15	17	37	31	15
16	16	18	38	32	16
17	24 V	10	30	32	17
18	0 V	9	29	31	18
19	24 V	20	40	38	19
20	0 V	19	39	37	20

ABF-M32H001

20-way HE 10 ①		Quantum		20-way HE 10 ②	
Terminal no.	Channel	Term. blk	Channels	Terminal no.	Terminal no.
1	1	1	21	17	1
2	2	2	22	18	2
3	3	3	23	19	3
4	4	4	24	20	4
5	5	5	25	21	5
6	6	6	26	22	6
7	7	7	27	23	7
8	8	8	28	24	8
9	9	11	31	25	9
10	10	12	32	26	10
11	11	13	33	27	11
12	12	14	34	28	12
13	13	15	35	29	13
14	14	16	36	30	14
15	15	17	37	31	15
16	16	18	38	32	16
17	NC	NC	NC	NC	17
18	0 V	9/19 shunt	29/39 shunt	0 V	18
19	NC	NC	NC	NC	19
20	NC	NC	NC	NC	20
Power cable	24 V	10/20 shunt	30/40 shunt	24 V	Power supply cable

ABF-M08S202

Pair	SUB D	Modicon Term. blk	SUB D	Pair
1	2	4		1
2	16	8		2
3	5	14		3
4	19	18		4
5	8	24		5
6	22	28		6
7	11	34	36	7
8	25	38	13	8

ABF-M16S201

Pair	SUB D	Modicon Term. blk	SUB D	Pair
1	14	2	1	2
2	3	4	3	16
3	17	6	5	5
4	6	8	7	19
5	20	12	11	8
6	9	14	13	22
7	23	16	15	11
8	12	18	17	25
1	14	22	21	2
2	3	24	23	16
3	17	26	25	5
4	6	28	27	19
5	20	32	31	8
6	9	34	33	22
7	23	36	35	11
8	12	38	37	25

ABF-M08S201

Pair	SUB D	Quantum Term. blk	SUB D	Pair
1	1	1	3	2
2	3	6	2	14
3	15	5	7	16
4	4	11	13	5
5	17	12	16	6
6	18	15	17	19
7	7	21	23	8
8	20	22	26	9
9	21	25	27	22
10	10	31	33	11
11	23	32	36	12-13
12	24	35	37	25

ABF-M04S200

Pair	SUB D	Quantum Term. blk	SUB D	Pair
1	14	2	1	1
5	2	8		5
2	3	12	11	15
6	16	18		6
3	17	22	21	4
7	5	28		7
4	6	32	31	18
8	19	38		8

ABF-M04S201

Pair	SUB D	Quantum Term. blk	SUB D	Pair
5	14	2	1	2
1	14	10	9	1
6	3	12	11	16
2	3	20	19	15
7	17	22	21	5
3	17	30	29	4
8	6	32	31	19
4	6	40	39	18

Connection interfaces

Telefast® 2 pre-wired system
Connection cables for Allen Bradley PLCs

816502

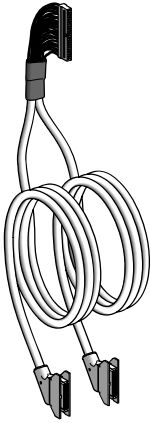

ABF-H40H00

4

Connection cables for Allen Bradley SLC 500 PLCs

Type of signal	Type of connection		Gauge AWG	Cross-section mm ²	Length m	Modularity	Reference	Weight kg
	PLC end	Telefast end						
32-channel Input	40-way HE 10	2 x 20-way HE 10	22	0.324	1.5	16	ABF-H40H150	0.350
		3				ABF-H40H300	0.800	
100 mA 32-channel output	40-way HE 10	2 x 20-way HE 10	22	0.324	1.5	16	ABF-H40H151	0.350
		3				ABF-H40H301	0.800	
16-channel Input	Terminal block	1 x 20-way HE 10	22	0.324	2	16	ABF-R16H201	0.800
16-channel output	Terminal block	1 x 20-way HE 10	22	0.324	2	16	ABF-R16H200	0.800

Correspondence tables

Cables for Allen Bradley PLCs
ABF-H40H00

20-way HE 10 ①		SLC 500 1 x 40-way HE 10		20-way HE 10 ②	
Terminal no.	Channels	HE 10	HE 10	Channels	Terminal no.
1	0	5	6	16	1
2	1	7	8	17	2
3	2	9	10	18	3
4	3	11	12	19	4
5	4	13	14	20	5
6	5	15	16	21	6
7	6	17	18	22	7
8	7	19	20	23	8
9	8	21	22	24	9
10	9	23	24	25	10
11	10	25	26	26	11
12	11	27	28	27	12
13	12	29	30	28	13
14	13	31	32	29	14
15	14	33	34	30	15
16	15	35	36	31	16
17	NC			NC	17
18	0 V	1	2	0 V	18
19	NC			NC	19
20	0 V	39	40	0 V	20

ABF-H40H01

20-way HE 10 ①		SLC 500 1 x 40-way HE 10		20-way HE 10 ②	
Terminal no.	Channels	HE 10	HE 10	Channels	Terminal no.
1	0	5	6	16	1
2	1	7	8	17	2
3	2	9	10	18	3
4	3	11	12	19	4
5	4	13	14	20	5
6	5	15	16	21	6
7	6	17	18	22	7
8	7	19	20	23	8
9	8	21	22	24	9
10	9	23	24	25	10
11	10	25	26	26	11
12	11	27	28	27	12
13	12	29	30	28	13
14	13	31	32	29	14
15	14	33	34	30	15
16	15	35	36	31	16
17	24 V	1	2	24 V	17
18	0 V	37	38	0 V	18
19	24 V	3	4	24 V	19
20	0 V	39	40	0 V	20

ABF-R16H200

20-way HE 10	SLC 500 Terminal block		20-way HE 10
17-19	0 V	OUT 0	1
2	OUT 1	OUT 2	3
4	OUT 3	OUT 4	5
6	OUT 5	OUT 6	7
8	OUT 7	OUT 8	9
10	OUT 9	OUT 10	11
12	OUT 11	OUT 12	13
14	OUT 13	OUT 14	15
16	OUT 15	0 V	18-20

ABF-R16H201

20-way HE 10	SLC 500 Terminal block		20-way HE 10
-	-	IN 0	1
2	IN 1	IN 2	3
4	IN 3	IN 4	5
6	IN 5	IN 6	7
8	IN 7	IN 8	9
10	IN 9	IN 10	11
12	IN 11	IN 12	13
14	IN 13	IN 14	15
16	IN 15	0 V	18-20

Connection interfaces

Telefast® 2 pre-wired system
Connection cables for Siemens PLCs

Connection cables for Siemens S5 PLCs

Type of signal	Type of connection PLC end	Type of connection Telefast end	Gauge AWG	Cross-section mm ²	Length m	Modularity	Reference	Weight kg
24 V Input and relay output	2 x 14-way HE 10	1 x 20-way HE 10	26	0.13	1.5	16	ABF-H28H150	0.150
						3 16	ABF-H28H300	0.250
8-channel I/O	Extension plate	2 x 20-way HE 10	22	0.32	2	2 x 8	ABF-S16H200	0.600
0.5 A output	1 x 14-way HE 10	1 x 20-way HE 10	26	0.13	1.5	8	ABF-H14H150	0.150
						3 8	ABF-H14H300	0.350

Connection cables for Siemens S7 PLCs

24 V Input and relay output	2 x 16-way HE 10	1 x 20-way HE 10	26	0.13	1.5	16	ABF-H32H150	0.160
						3 16	ABF-H32H300	0.260
8-channel Input	Terminal block	1 x 20-way HE 10	22	0.32	2	8	ABF-S08H202	0.350
0.5 A output	1 x HE 10	1 x HE 10	26	0.13	1.5	8	ABF-H16H150	0.160
						3 8	ABF-H16H300	0.260
8-channel output Analogue	Terminal block Bare wires	1 x 20-way HE 10 25-way SUB-D	22	0.32	2	8	ABF-S08H203	0.350
14-channel Input 10-chan.output	Terminal block	2 x 20-way HE 10	22	0.32	2	24	ABF-F25S200	0.600
						24	ABF-S24H200	0.920

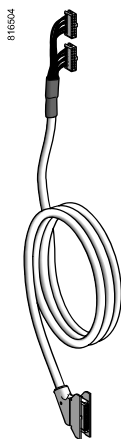

ABF-H32Hee0

Correspondence tables

Cables for Siemens PLCs
ABF-H14Hee0

20-way HE 10 Term. no.	Channels	Siemens S5 14-way HE 10
1	0	1
2	1	2
3	2	3
4	3	4
5	4	5
6	5	6
7	6	7
8	7	8
9	NC	
10	NC	
11	NC	
12	NC	
13	NC	
14	NC	
15	NC	
16	--- 24 V	9
17	--- 24 V	11
18	--- 0 V	12
19	--- +24 V	13
20	--- 0 V	14

ABF-H28Hee0

20-way HE 10 Term. no.	Channels	Siemens S5 2 x 14-way HE 10
1	0	1
2	1	2
3	2	3
4	3	4
5	4	5
6	5	6
7	6	7
8	7	8
9	8	
10	9	
11	10	
12	11	
13	12	
14	13	
15	14	
16	15	
17	--- 24 V	13
18	--- 0 V	14
19	--- 24 V	13
20	--- 0 V	14

ABF-H16Hee0

20-way HE 10 Term. no.	Channels	Siemens S7 16-way HE 10
1	0	16
2	1	14
3	2	12
4	3	10
5	4	8
6	5	6
7	6	4
8	7	2
9	NC	
10	NC	
11	NC	
12	NC	
13	NC	
14	NC	
15	--- 24 V	9
16	--- 24 V	11
17	--- 24 V	13
18	--- 0 V	1
19	--- 24 V	15
20	--- 0 V	3

ABF-H32Hee0

20-way HE 10 Term. no.	Channels	Siemens S7 2 x 16-way HE 10
1	0	16
2	1	14
3	2	12
4	3	10
5	4	8
6	5	6
7	6	4
8	7	2
9	8	
10	9	
11	10	
12	11	
13	12	
14	13	
15	14	
16	15	
17	--- 24 V	13
18	--- 0 V	1
19	--- 24 V	13
20	--- 0 V	1

ABF-S16H200

20-way HE 10 Term. no.	Chans.	Siemens S5 Extension plate	Chans.
13-14-15-17-19	--- 24 V	1	--- 24 V
18-20	--- 0 V	2	--- 0 V
2	E1	3	E1
1	E0	4	E0
4	E3	5	E3
3	E2	6	E2
6	E5	7	E5
5	E4	8	E4
8	E7	9	E7
7	E6	10	E6

ABF-S24H200

20-way HE 10 Term. no.	Chans.	Siemens S7 Terminal block	20-way HE 10 Chans.
18	0 V	1 M	0 V
1	0	0.0	1 L+ +24 V
2	1	0.1	0.0
3	2	0.2	0.1
4	3	0.3	0.2
5	4	0.4	0.3
6	5	0.5	0.4
7	6	0.6	2 M 0 V
8	7	0.7	2 L+ +24 V
20	0 V	2 M	0.5
9	8	1.0	0.6
10	9	1.1	0.7
11	10	1.2	1.0
12	11	1.3	1.1
13	12	1.4	—
14	13	1.5	—

ABF-S08H203

20-way HE 10 Term. no.	Chans.	Siemens S7 Term. block
18	--- 0 V	1 M
13-14-15	--- 24 V	1 L+
1	E1	0,0
2	E2	0,1
3	E3	0,2
4	E4	0,3
20	--- 0 V	2 M
16-17-19	--- 24 V	2 L+
1	E1	0,4
2	E2	0,5
3	E3	0,6
4	E4	0,7

ABF-S08H202

20-way HE 10 Term. no.	Chans.	Siemens S7 Term. block
13-14-15	--- 24 V	1 M
1	E1	0,0
2	E2	0,1
3	E3	0,2
4	E4	0,3
16-17-19	--- 24 V	2 M
5	E5	0,4
6	E6	0,5
7	E7	0,6
8	E8	0,7

Common side view

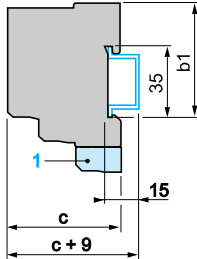

ABE-7H20E●●●
ABE-7H32E●●●

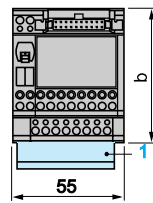

ABE-7H16R50, ABE-7H12R50,
ABE-7H08R1●, ABE-7H08R21,
ABE-7R08S111/S111E,
ABE-7H08S21, ABE-7CPA21

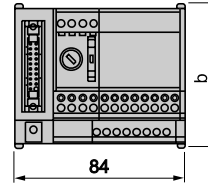

ABE-7H16C●●/ABE-7H16CM●●,
ABE-7●16M111/ABE-7●16T111

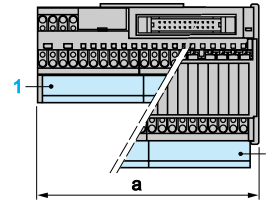

ABE-	7H20E/7H32E●●●	7H●●●●/CPA21	7R08S111●
b	67	70	77
b1	56	58	58
c	59	58	58

1 Additional shunt terminal block ABE-7BV10/7BV20

Common side view

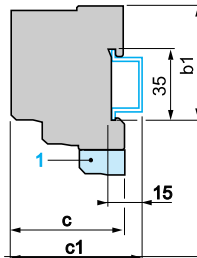

ABE-7H16R2●, ABE-7H12R2●, ABE-7H16R3●,
ABE-7H16R1●, ABE-7H12R1●, ABE-7H12S21,
ABE-7H16S2●, ABE-7R16S11●, ABE-7R08S210,
ABE-7S08S2B0, ABE-7CPA02, ABE-7CPA03
ABE7S16S1B2, ABE-7R08S216

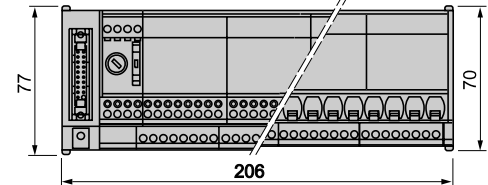
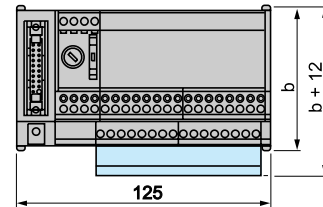

ABE-	7●●●●●	7●R08S210●, 7S16S1B2●, 7R08S216
b	70	77
b1	58	58
c	58	58

1 Additional shunt terminal block ABE-7BV10/7BV20

ABE-7R16T2●●, ABE-7P16T2●●

All sub-bases	
b1	58
c	58

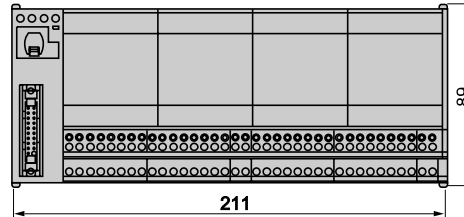
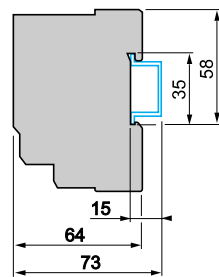

ABE-7CPA01, ABE-7CPA11/CPA12/CPA13

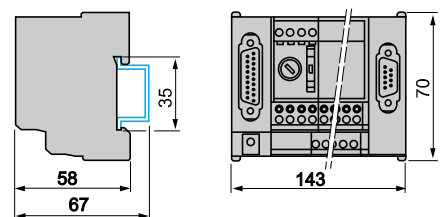

Note:
details of the front view are the same as for the ABE-7CPA01.

ABE-7R16T3●●, ABE-7P16T3●●, ABE-7P16F31●

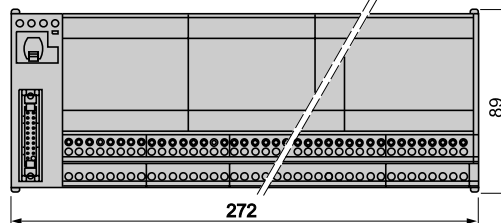
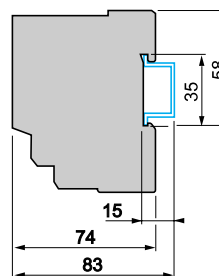

ABE-7P08T330

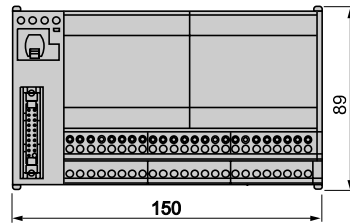

Presentation, compatibility:
pages 4/8 to 4/25

Characteristics:
pages 4/26 to 4/33

References:
pages 4/36 to 4/51

Schemes:
pages 4/52 to 4/63

ABE-7ACC02

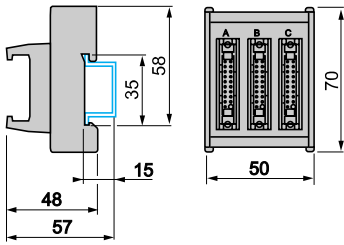

ABE-7ACC03

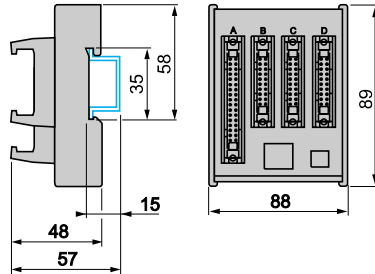

ABE-7ACC04, ABE-7ACC05
ABE-7ACC10, ABE-7ACC11

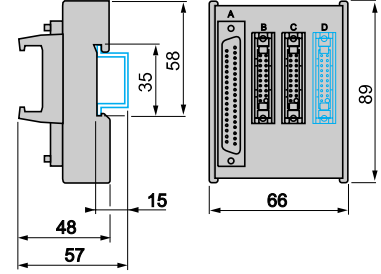

Note: Drawing representing ABE-7ACC04 and ABE-7ACC05

ABE-7ACC80

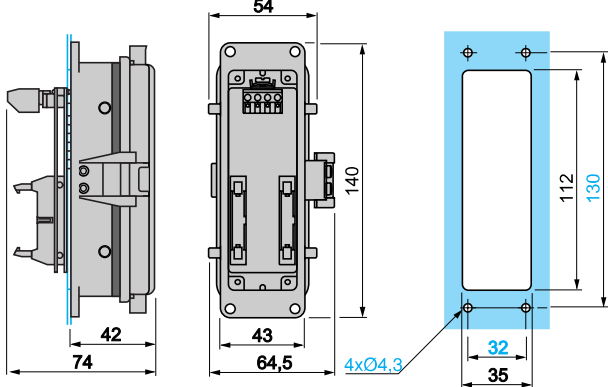

ABE-7ACC82, ABE-7ACC83

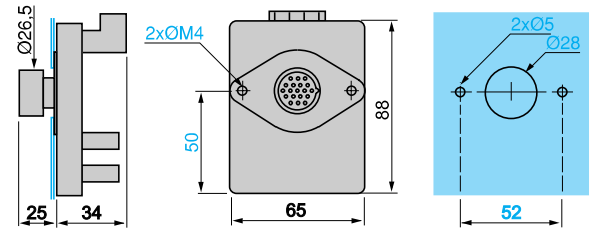

ABE-7ACC84

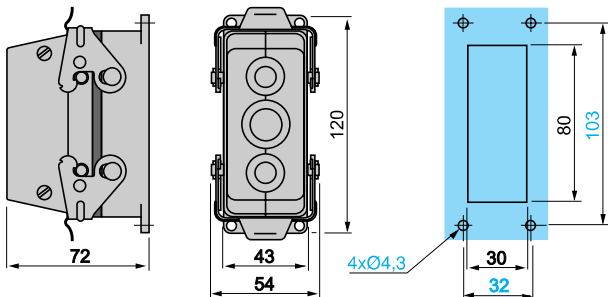

ABE-7TES160

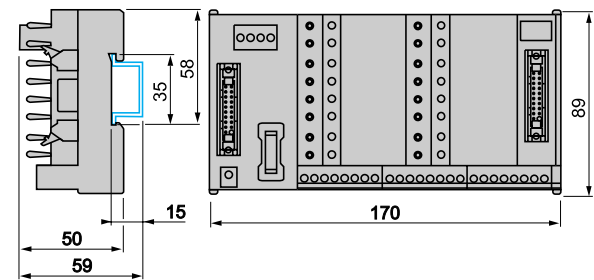

Fixing centres for sub-bases using mounting kit ABE-7ACC01

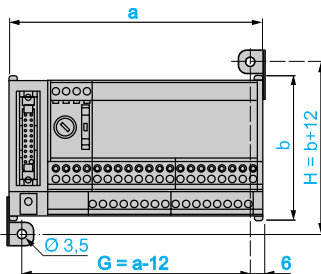

ABE-7	G	H
ACC02	38	82
ACC03	53	101
ACC04	53	101
ACC05	53	101
ACC10/11	53	101
H08R●●	72	82
H08S21	72	82
H12R50	72	82
H16R50	72	82
R08S111	72	82
CPA01	131	82
CPA02	113	82
CPA1●	131	82
CPA03	113	82

ABE-7	G	H
H12R1●	113	82
H12R2●	113	82
H16R1●	113	82
H16R2●	113	82
H16R3●	113	82
H12S21	113	82
H16S21	113	82
R08S210	113	82
R16S111	113	82
R16S21●	194	82
S08S2B0	113	82
S08S2B1	194	82

ABE-7	G	H
H16F43	194	82
H16S43	194	82
S16E2●●	194	82
S16S1B2	113	82
S16S2●●	194	82
R16T2●●	199	101
P16T2●●	199	101
R16T3●●	260	101
P08T330	150	101
P16T3●●	260	101
P16F3●●	260	101

Presentation, compatibility:
pages 4/8 to 4/25

Characteristics:
pages 4/26 to 4/33

References:
pages 4/36 to 4/51

Schemes:
pages 4/52 to 4/63

Connection of terminal block common (on sub-bases ABE-7H●●S21 and ABE-7H16R3● only)

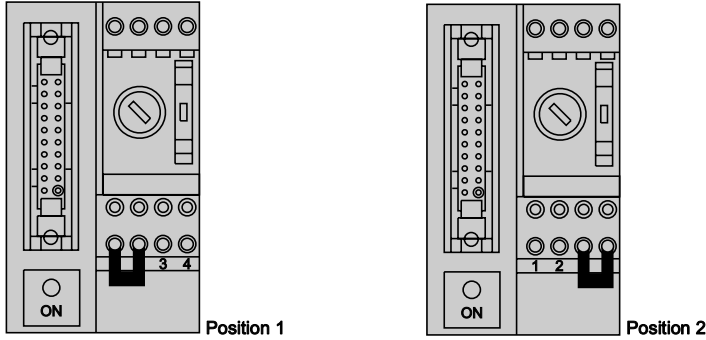

Connection is made using a shunt.
 The shunt is supplied with the sub-base and is mounted in the neutral position between terminals 2-3.
 It may be connected:
 -either to + for positive logic inputs across terminals 1-2 (position 1),
 -or to - for positive logic outputs across terminals 3-4 (position 2).
 For sub-bases ABE-7H16R3●, the shunt is in position 1.
 A second wire shunt must be connected -between the 3rd row common (C) and first row terminal 4 (OV).

4

ABE-7H08S21

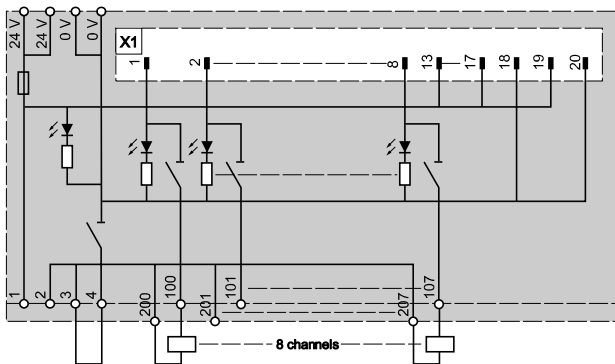

ABE-7H12S21

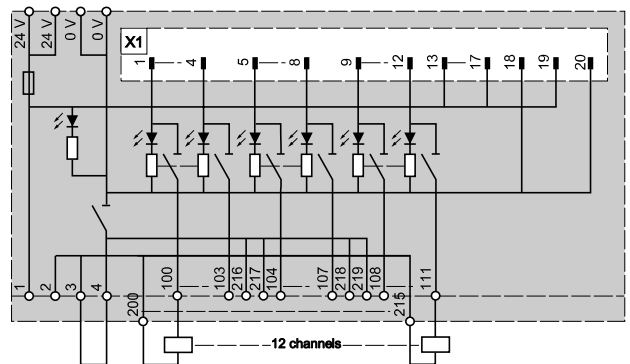

ABE-7H08R●● (R10 with no LED)

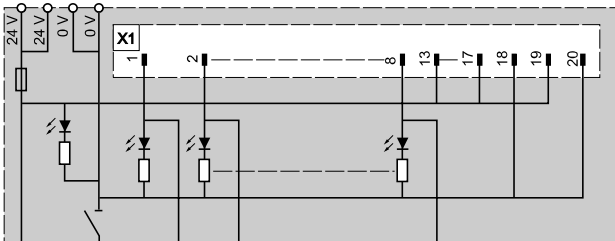

ABE-7H12R●● (R20, R10 and R50 with no LED)

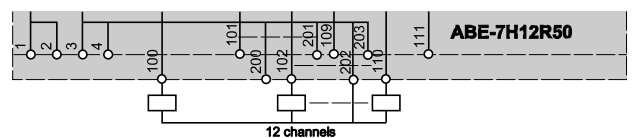
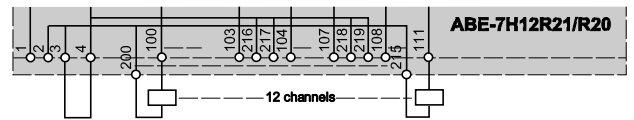
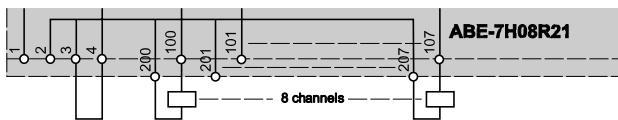
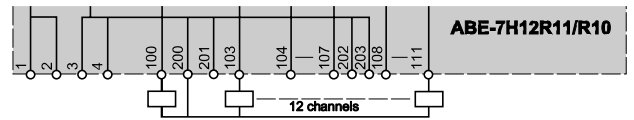
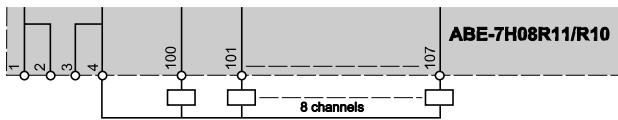
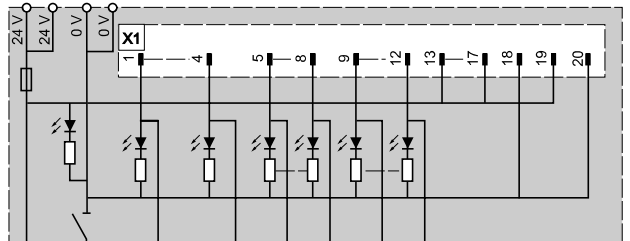

ABE-7H16S21

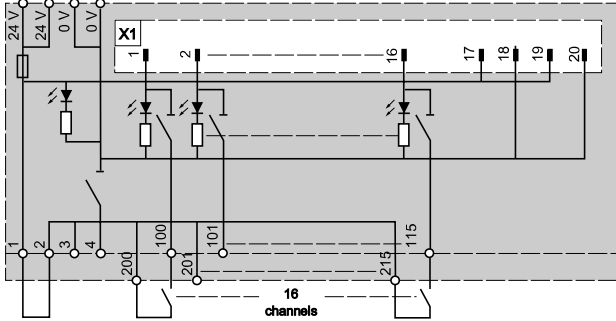

ABE-7H16F43

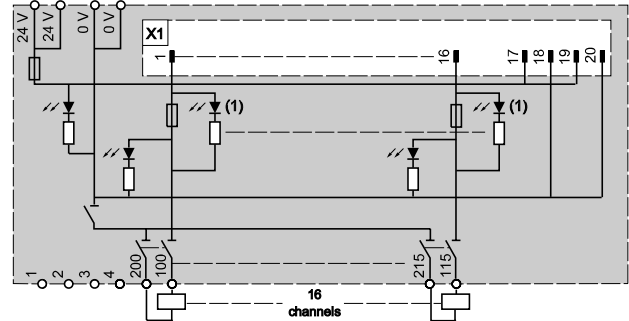

ABE-7H●●●●● (C10, R20, R10, R30 and R 50 without LED)

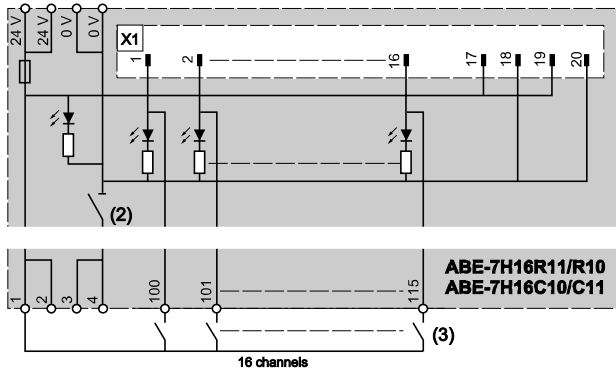

(1) LED fuse blown.
ABE-7H16S43

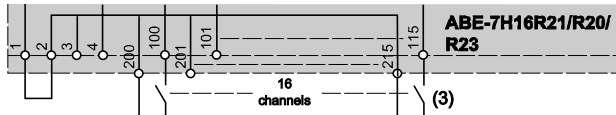
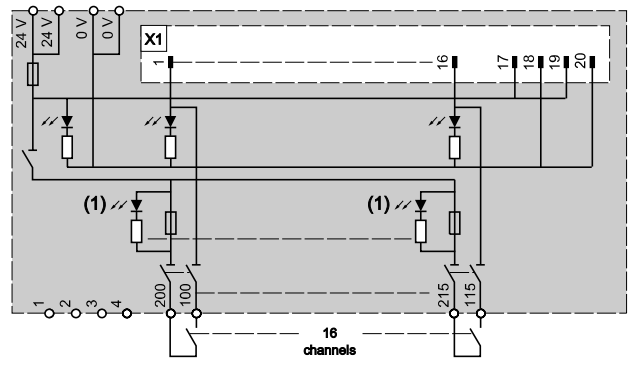

(1) LED fuse blown.
ABE-7H16C●1

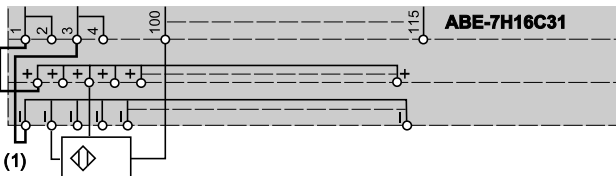
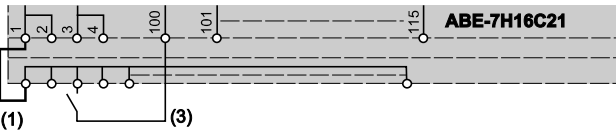
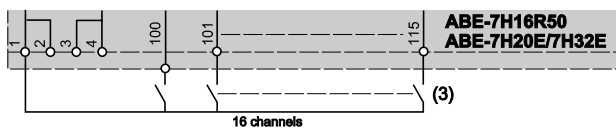
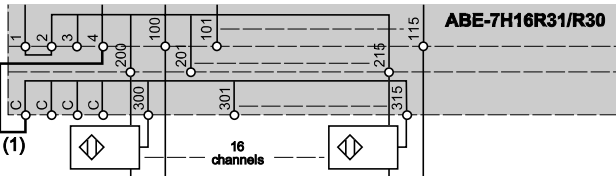
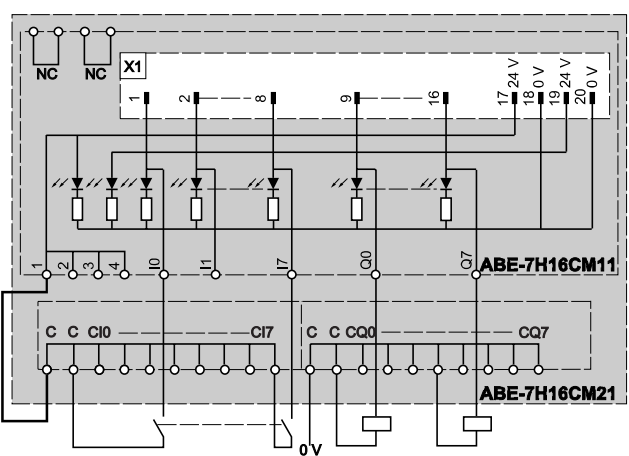

Warning

The wiring diagrams above are recommended for inductive loads and are valid for all sub-bases equipped with electromechanical relays.

Self-protected relays ABS-7SC3BA (≡ 24 V/2 A) do not require any special protection.

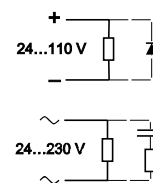

- (1) The user must connect 1 and 2, 4 and C
- (2) No isolator on refs. ABE-7H●●E●●/7H16C●●

(3) Example of input wiring

ABE-7R08S111

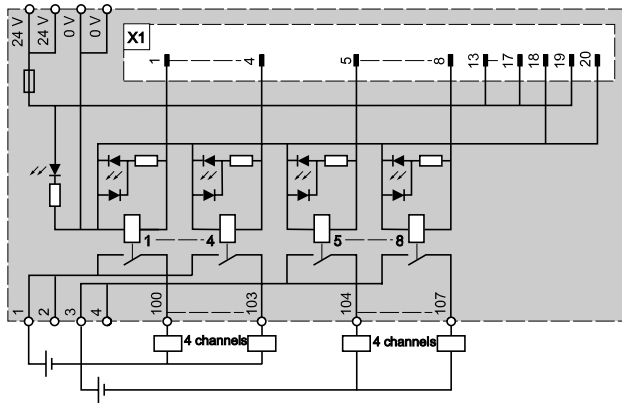

ABE-7R16S111

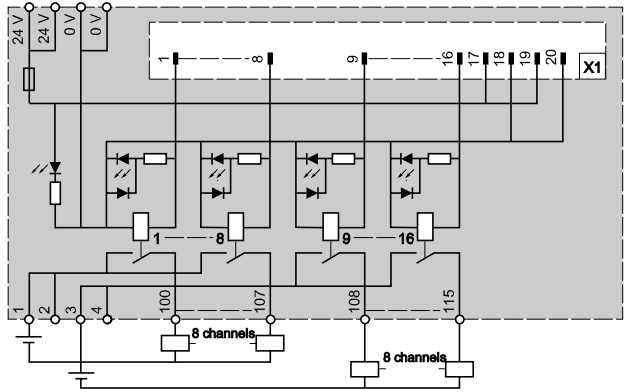

4

ABE-7R08S210

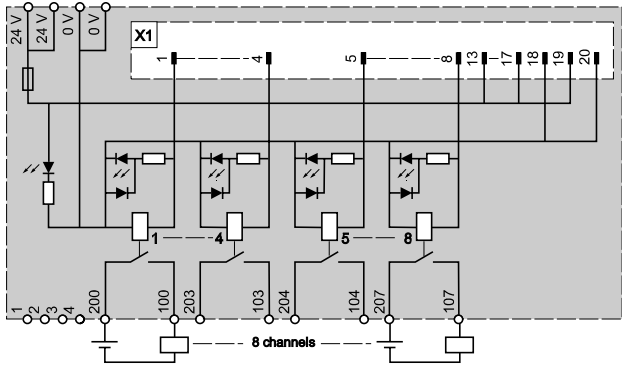

ABE-7R16S210

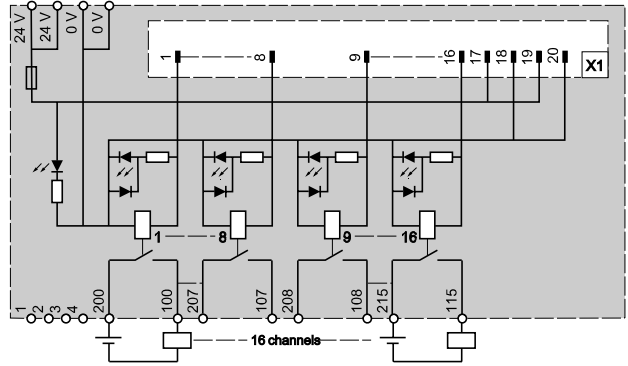

ABE-7R08S216

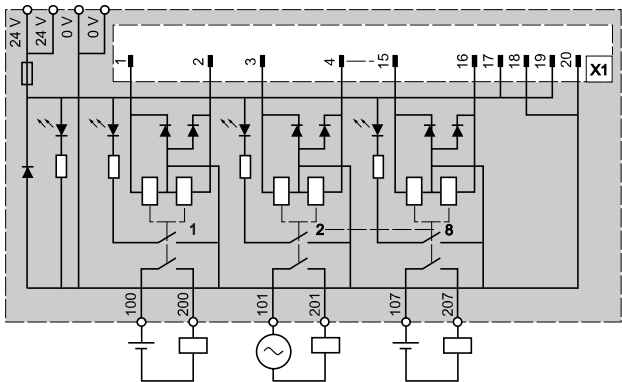

ABE-7R16S212

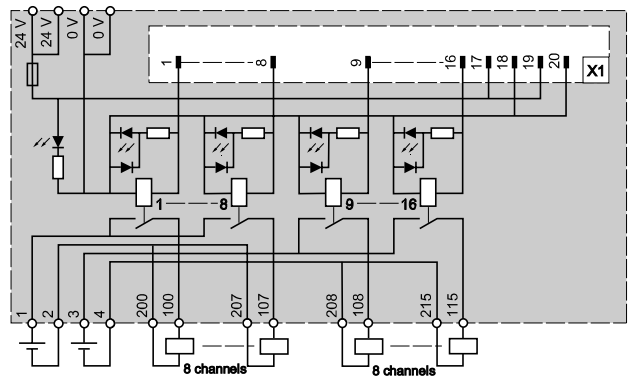

ABE-7P16T212 (1), ABE-7R16T212, ABE-7P16T215 (1)

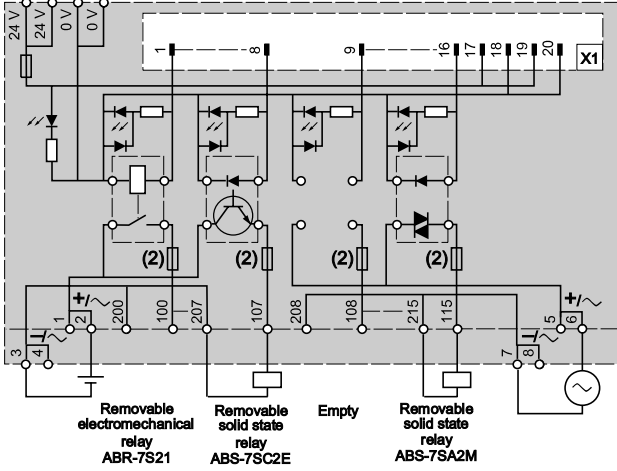

ABE-7P16T111 (1), ABE-7R16T111

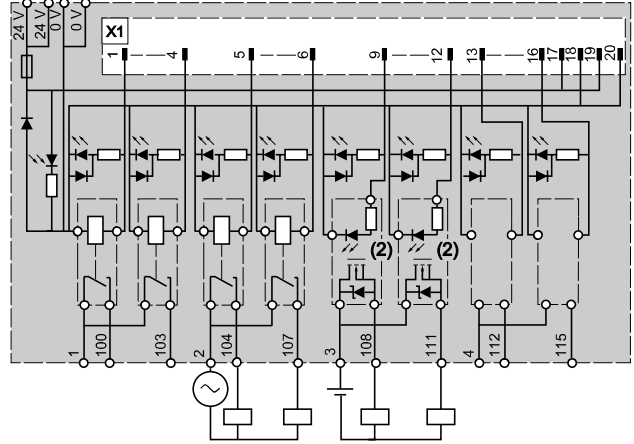

- (1) Sub-bases not equipped with relay.
- (2) ABS-7SC1B solid state relays can be installed.

- (1) ABR-7S11 sub-bases not equipped with relay.
- (2) ABS-7SC1B solid state relays can be installed.

ABE-7P16M111 (1), ABE-7R16M111

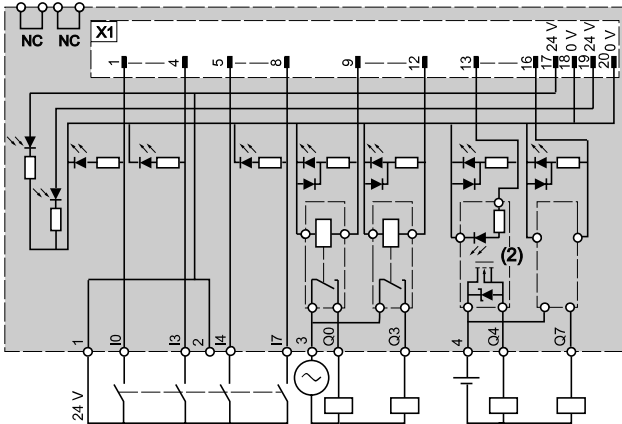

ABE-7P16T230 (1)

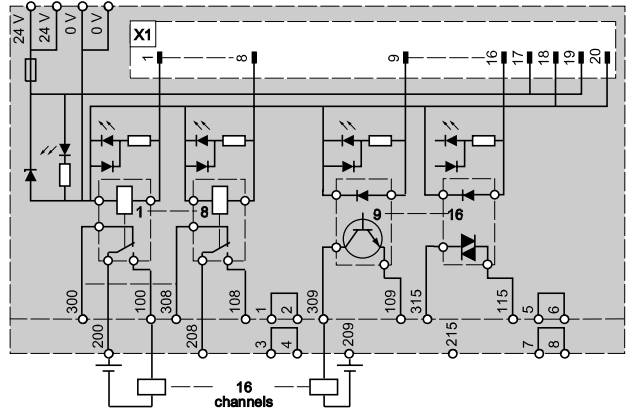

- (1) ABR-7S11 sub-bases not equipped with relay.
- (2) ABS-7SC1B solid state relays can be installed.

- (1) ABS-7S21 solid state relays can be installed on the sub-base.

ABE-7R16T231

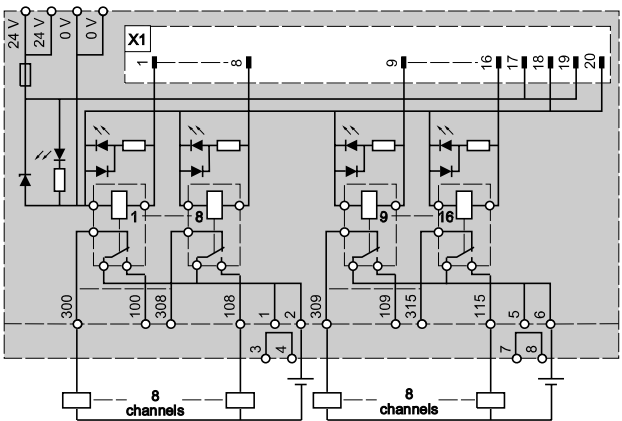

ABE-7P16T210, ABE-7R16T210 (1), ABE-7P16T214 (1)

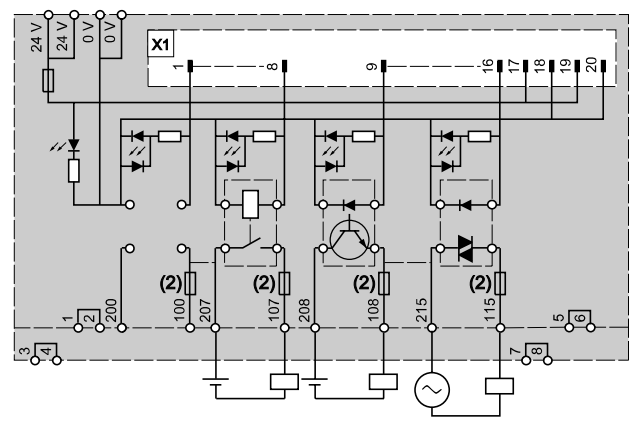

- (1) Sub-base not equipped with relays.
- (2) Fuses only on ABE-7P16T214.

Presentation, compatibility:
pages 4/8 to 4/25

Characteristics:
pages 4/26 to 4/33

References:
pages 4/36 to 4/51

Dimensions:
pages 4/52 to 4/53

ABE7P08T330 (1)

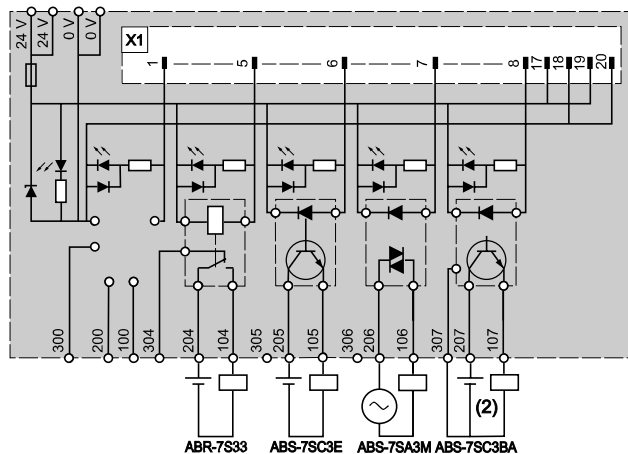

ABE-7R16T330, ABE-7P16T330 (1), ABE-7P16T334 (1)

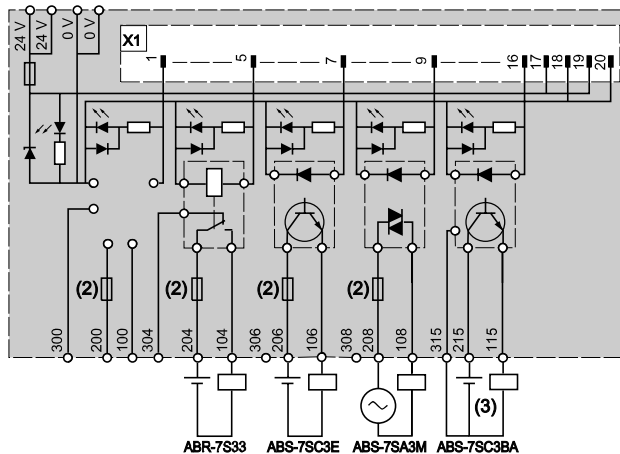

- (1) Sub-base not equipped with relay.
 (2) Connection of ABS-7SC3BA solid state relay.

- (1) Sub-base not equipped with relay.
 (2) Fuses only on ABE-7P16T334.
 (3) Connection of ABS-7SC3BA solid state relay.

ABE-7P16T318 (1)

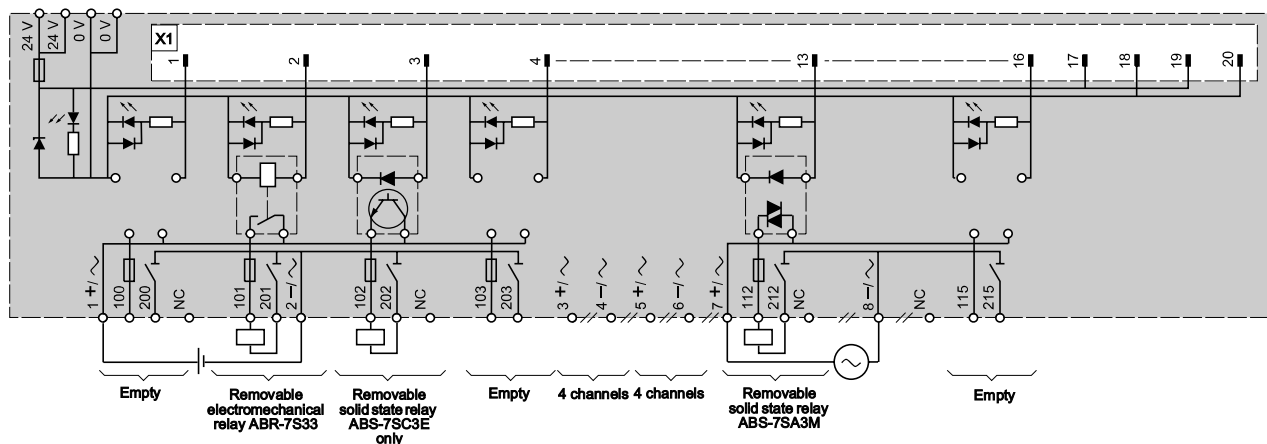

- (1) Sub-base not equipped with relay.

ABE-7R16T332 (1), ABE-7P16T332

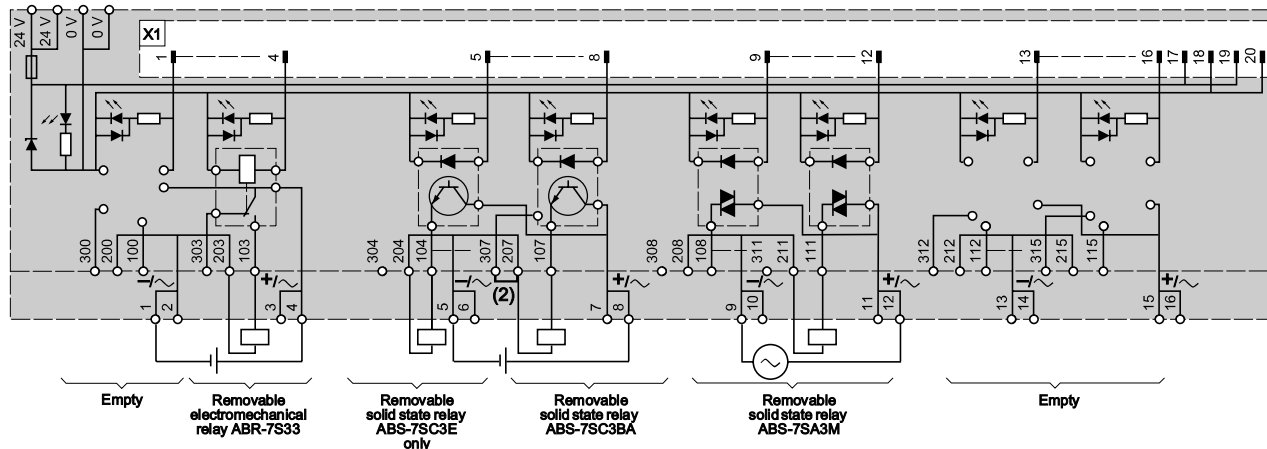

- (1) Sub-base not equipped with relay.
 (2) Required jumper supplied with relay ABS-7SC3BA.

Presentation, compatibility:
 pages 4/8 to 4/25

Characteristics:
 pages 4/26 to 4/33

References:
 pages 4/36 to 4/51

Dimensions:
 pages 4/52 to 4/53

ABE-7R16T370

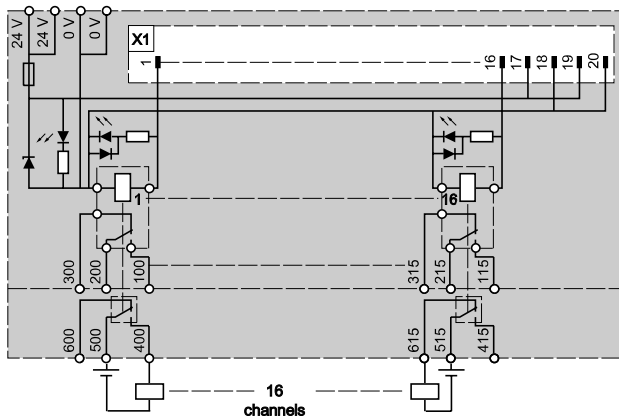

ABE-7P16F310 (1)

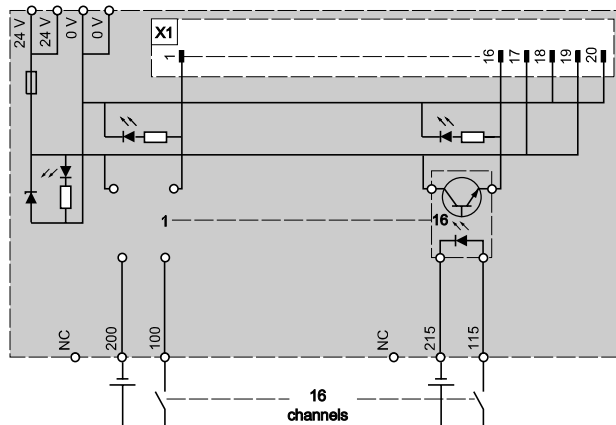

(1) Sub-base not equipped with relay.

ABE-7P16F312 (1)

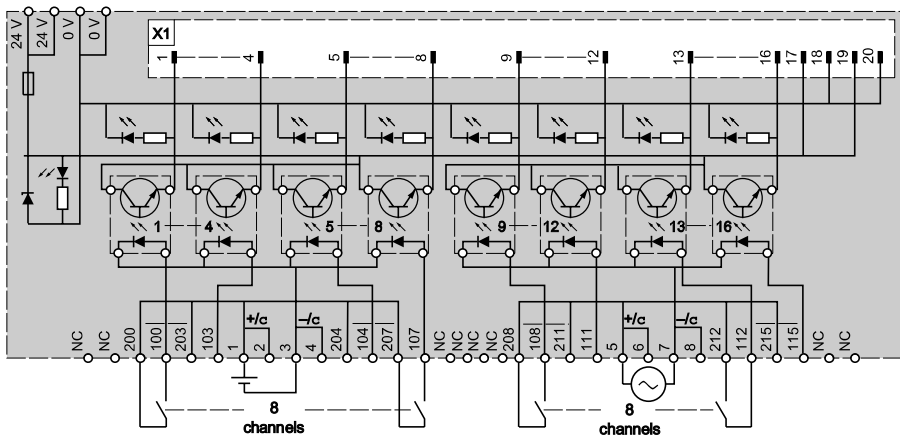

(1) Sub-base not equipped with relay.

ABE-7S16E2●●

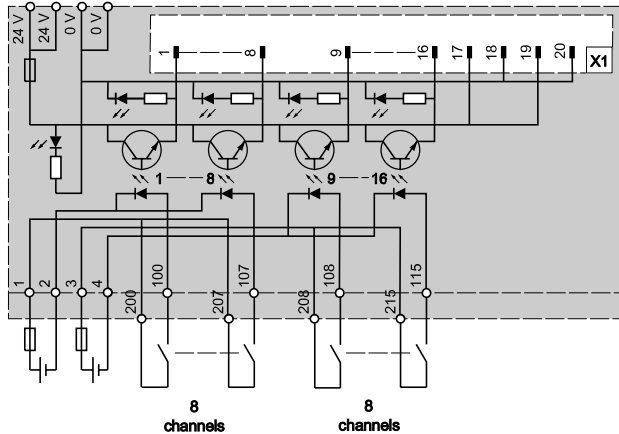

ABE-7S16S1B2/ABE-7S16S2B0

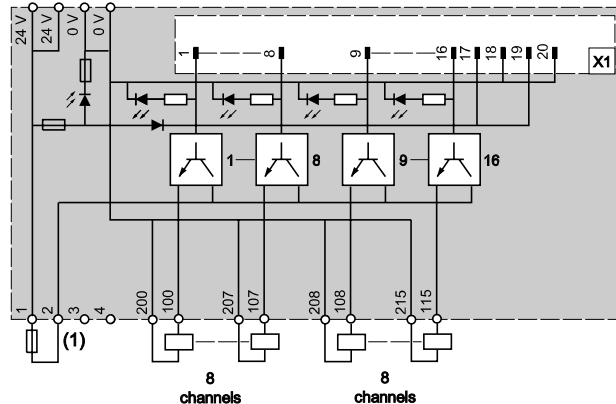

(1) The user must connect the protection fuse across terminals 1 and 2.

Presentation, compatibility:
pages 4/8 to 4/25

Characteristics:
pages 4/26 to 4/33

References:
pages 4/36 to 4/51

Dimensions:
pages 4/52 to 4/53

ABE-7S08S2B0

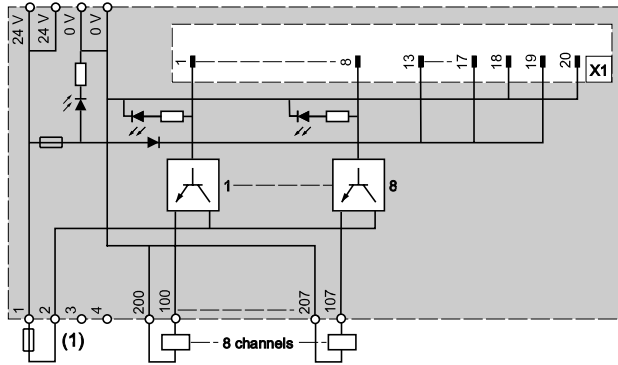

ABE-7S08S2B1

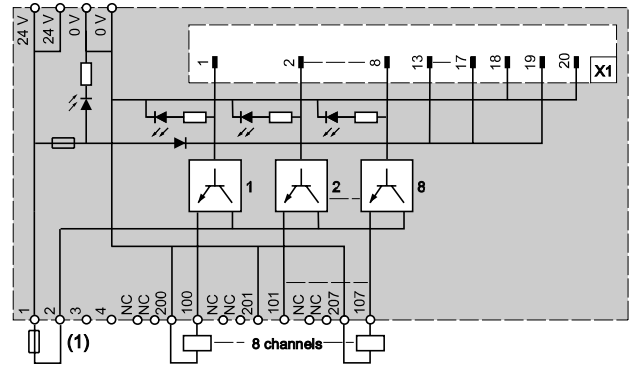

(1) The user must connect the protection fuse across terminals 1 and 2.
ABE-7CPA01

(1) The user must connect the protection fuse across terminals 1 and 2.
ABE-7CPA02

4

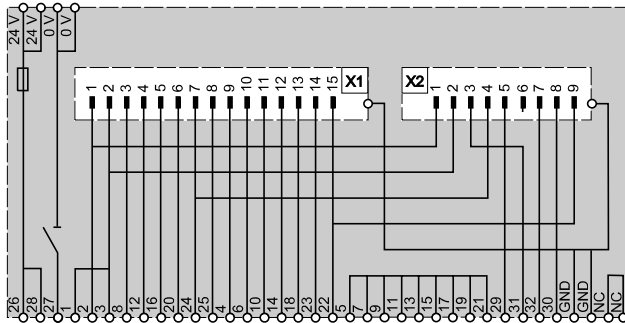

ABE-7CPA11

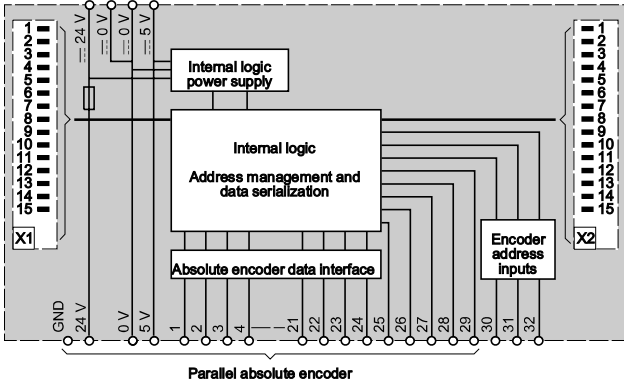

X1 To Premium module

X2 To Telefast

ABE-7CPA21

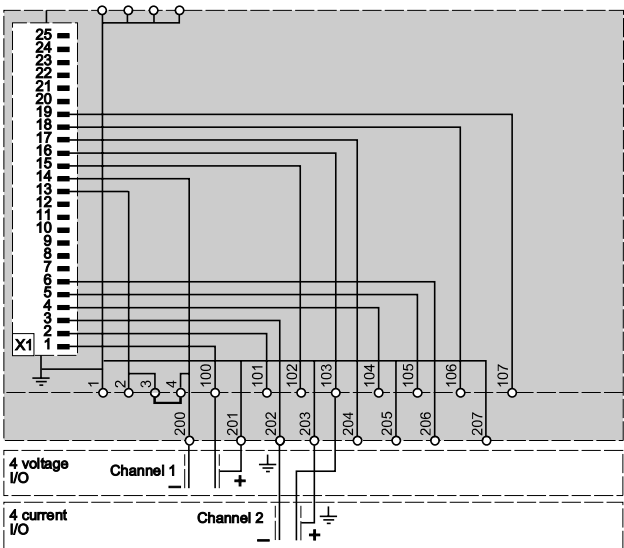

ABE-7CPA12

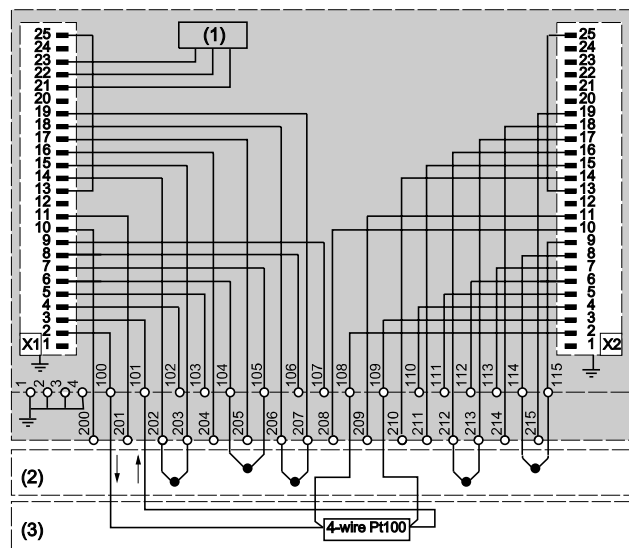

- (1) Temperature probe
- (2) Used in cold junction compensation mode in the Telefast sub-base
- (3) Used in cold junction compensation mode by external 4-wire Pt100

ABE-7CPA31

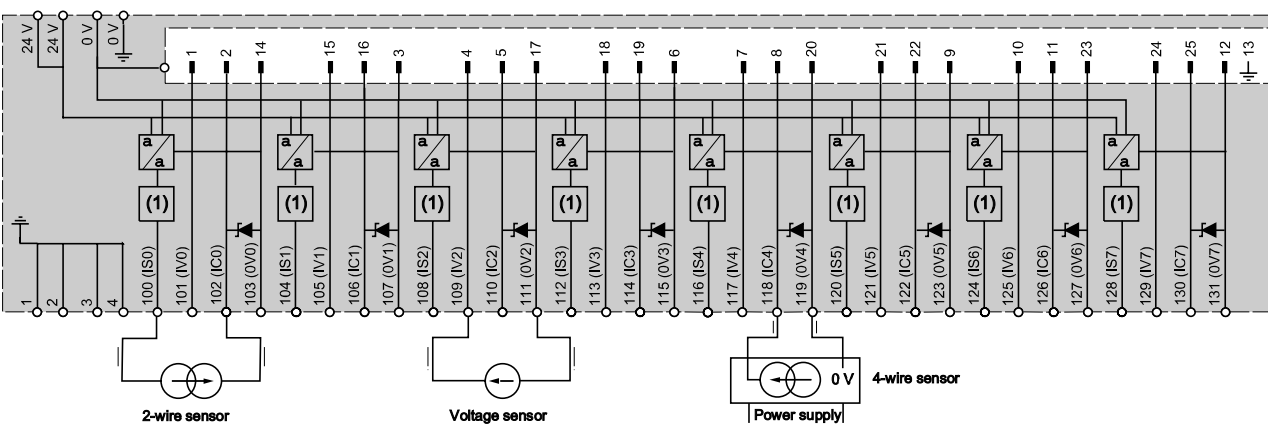

(1) 25 mA protection

Presentation, compatibility:
pages 4/8 to 4/25

Characteristics:
pages 4/26 to 4/33

References:
pages 4/36 to 4/51

Dimensions:
pages 4/52 to 4/53

ABE-7ACC02

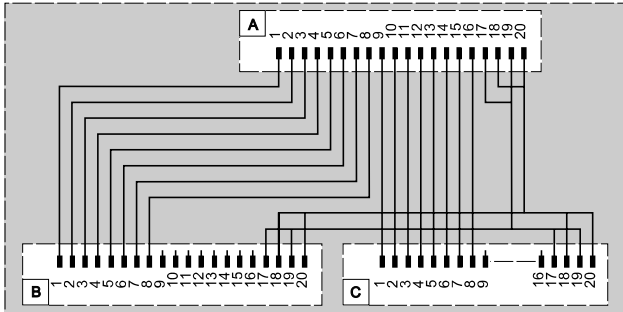

ABE-7ACC03

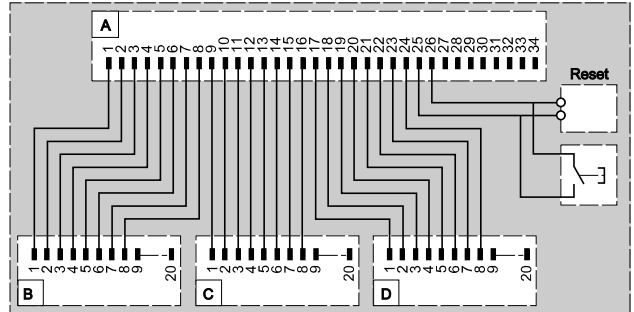

4

Enclosure feedthrough
With 40-way industrial connector
ABE-7ACC80

20-way HE 10		Industrial connector		20-way HE 10	
Term no.	Channel	Pin no.	Channel	Term no.	
1	0	C16	B16	16	1
2	1	C15	B15	17	2
3	2	C14	B14	18	3
4	3	C13	B13	19	4
5	4	C12	B12	20	5
6	5	C11	B11	21	6
7	6	C10	B10	22	7
8	7	C9	B9	23	8
9	8	C8	B8	24	9
10	9	C7	B7	25	10
11	10	C6	B6	26	11
12	11	C5	B5	27	12
13	12	D5	A5	28	13
14	13	D6	A6	29	14
15	14	D7	A7	30	15
16	15	D8	A8	31	16
17	--- 24 V	A3	A3	--- 24 V	17
18	--- 0 V	C3	C3	--- 0 V	18
19	--- 24 V	B3	B3	--- 24 V	19
20	--- 0 V	D3	D3	--- 0 V	20

With CNOMO M23 connector
ABE-7ACC82

20-way HE 10		M23 connector	Removable power supp.
Term no.	Channel	Pin no.	Term. block
1	0	15	
2	1	5	
3	2	16	
4	3	3	
5	4	17	
6	5	2	
7	6	11	
8	7	1	
9	8	7	
10	9	4	
11	10	8	
12	11	14	
13	12	9	
14	13	13	
15	14	10	
16	15	18	
17/19	--- 24 V	19	B/C
NC	±	12	A
18/20	--- 0 V	6	D/E

ABE-7ACC83

20-way HE 10		M23 connector	Removable power supp.
Term no.	Channel	Pin no.	Term. block
1	0	15	
2	1	5	
3	2	16	
4	3	3	
5	4	17	
6	5	2	
7	6	11	
8	7	1	
9	8	7	
10	9	4	
11	10	8	
12	11	14	
NC		9	
NC		13	
NC		10	
NC		18	
NC	±	12	A
13/14/15/16/17/19	--- 24 V	19	B/C
18/20	--- 0 V	6	D/E

ABF-F25S200

Channel	25-way SUB-D	Colour
1	- 14	Black
	+ 1	Yellow
2	- 3	Black
	+ 15	Blue
3	- 17	Black
	+ 4	Green
4	- 6	Black
	+ 18	White
5	- 20	Green
	+ 7	Red
6	- 9	Red
	+ 21	White
7	- 23	Black
	+ 10	Orange
8	- 12	Black
	+ 24	Red

Simulation sub-base ABE-7TES160 Input connections

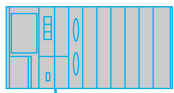

Inserted between the PLC and the operative part, the simulation sub-base is used to set the PLC inputs to 1 or 0 irrespective of the state of the operative part sensors.

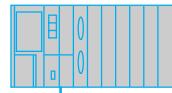

Connected to a PLC input module, the simulation sub-base enables signals to be forced to 1 or 0 and sensors to be connected to its screw terminals.

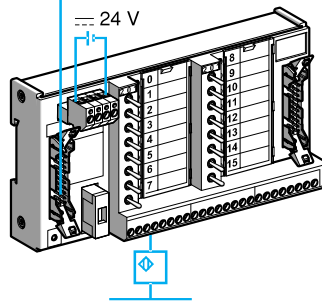
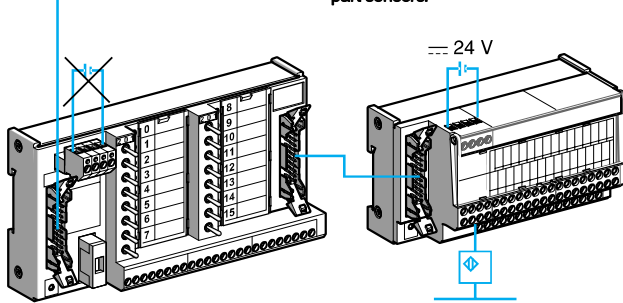

Output connections

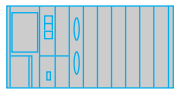

Inserted between the PLC and the operative part, the simulation sub-base is used to set the operative part actuators to 1 or 0 irrespective of the state of the PLC outputs.

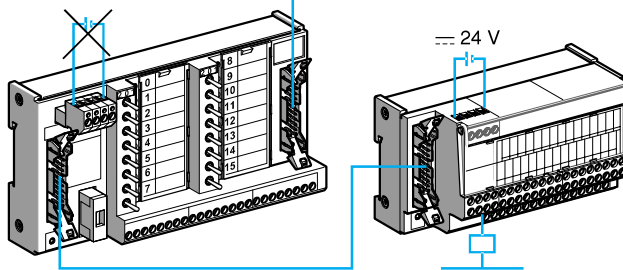

Input connection scheme

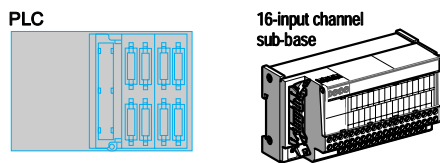

Output connection scheme

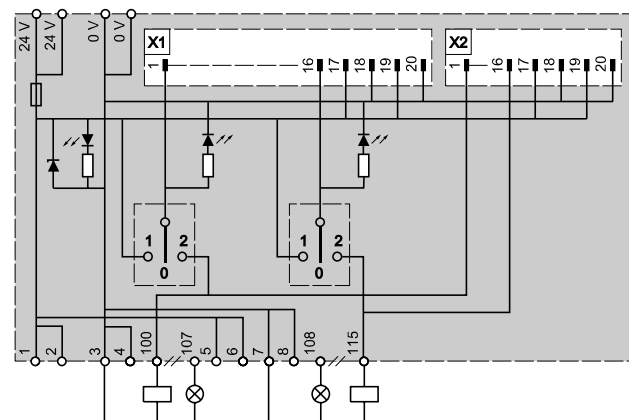
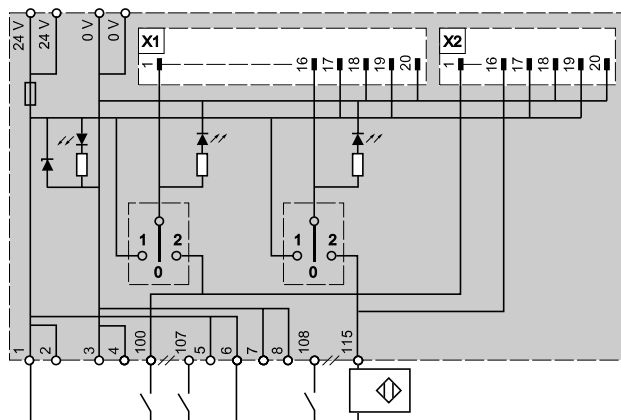
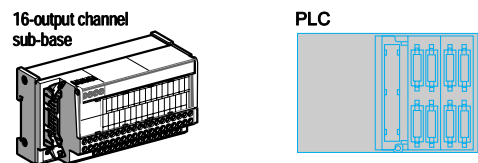

Index

- Product reference index page 8/2

Technical information

- Protective treatment according to climatic environment page 8/4
- Product standards and approvals page 8/6
- Degrees of protection provided by enclosures page 8/8

Schneider Electric worldwide

- Addresses page 8/10

Product reference index

A							
AB1 A10	6/37	AB1 AL6	6/37	AB1 CPe	6/44 to	AB1 RRCS●	6/24 to
AB1 A16	6/38	AB1 ALD100●	6/58		6/47		6/30
AB1 A2	6/36, 6/40, 6/48		and 6/59	AB1 CS●	6/36		and 6/33
	and 6/49	AB1 ALD12●	6/58		and 6/37	AB1 RRCS41	6/35
AB1 A35	6/39		and 6/59	AB1 CSN●●●	6/37 to	AB1 RRET1535UGR	6/32
AB1 A4	6/37	AB1 ALN10●●	6/37		6/39	AB1 RRET2535UNO	6/33
	and 6/62	AB1 ALN1502	6/39	AB1 CT●	6/44 to	AB1 RRETAC15	6/32
AB1 A6	6/37	AB1 ALN16●●	6/38		6/47	AB1 RRGF0●	6/24 to
AB1 AA135U2●●	6/10	AB1 ALN2●●	6/36	AB1 CT215	6/49		6/35
AB1 AA135U3●●	6/11	AB1 ALN35●	6/39	AB1 CV1	6/52	AB1 RRPS4	6/35
AB1 AA135U4●●	6/11	AB1 ALN4●●	6/37, 6/56	AB1 D11435U	6/65	AB1 RRSC435UGR	6/34
AB1 AA235U2●●	6/12		and 6/69	AB1 DDP235T●●	6/59	AB1 RRSCAC4	6/34
AB1 AA235U3●●	6/13	AB1 ALN6●●	6/37	AB1 DDP235U●●	6/58	AB1 RRSF435U	6/35
AB1 AA235U4●●	6/13	AB1 ALN702	6/39	AB1 DL02●	6/53	AB1 RRTP1●35U2	6/31
AB1 AAAC122●●	6/10, 6/12, 6/14	AB1 AS2	6/48		and 6/54	AB1 RRTP235U●	6/28
	and 6/16		and 6/49	AB1 DT01	6/52		and 6/29
AB1 AAAC123●●	6/11, 6/13, 6/15, 6/17, 6/20 to	AB1 AS24●●	6/36	AB1 DV0●	6/53 to	AB1 RRTP435U●	6/29
	6/23		and 6/37		6/55	AB1 RRTP635U2	6/30
AB1 AAAC124●●	6/11, 6/13, 6/15, 6/17, 6/18	AB1 AS4ET	6/57	AB1 DV10235U	6/54	AB1 RRTPAC24●	6/28
	and 6/19	AB1 AS6	6/37	AB1 DVM10235U	6/54		and 6/29
AB1 AAAS122●●	6/10	AB1 AS6BL	6/37	AB1 EBN●●	6/50, 6/51, 6/60	AB1 SBN	6/50
	and 6/12	AB1 ASN●●	6/37 to		6/60		and 6/51
AB1 AAAS123●●	6/11, 6/13, 6/20 to	AB1 AT●	6/10 to	AB1 ET3235U●●●	6/59	AB1 SC435U	6/62
	6/23		6/23, 6/36	AB1 ET435U●	6/57	AB1 SC435U2PT	6/62
AB1 AAAS124●●	6/11, 6/13, 6/15, 6/17, 6/18		to 6/41,	AB1 ET435U2DRO	6/57	AB1 SC435U2PTBL	6/62
	and 6/19		6/48, 6/49	AB1 ET435UB●●●	6/57	AB1 SC435UBL	6/62
AB1 AAAS125●●	6/10	AB1 B15	6/48	AB1 ET435UHBRO	6/57	AB1 SF435U	6/64
	and 6/12		and 6/49	AB1 ET435UTP	6/57	AB1 SF520●	6/22, 6/23, 6/35
AB1 AAAS126●●	6/11, 6/13, 6/20 to	AB1 B22	6/48	AB1 ETN●35U	6/56		and 6/64
	6/23		and 6/49	AB1 ETNTP435U	6/56	AB1 SM1N	6/60
AB1 AAAS124●●	6/11, 6/13, 6/18	AB1 BB18535	6/45	AB1 FC335U	6/69		and 6/61
	and 6/19	AB1 BB24035	6/45	AB1 FF235U	6/69	AB1 SV●	6/22, 6/23, 6/35
AB1 AAC81JA	6/10	AB1 BB9535	6/44	AB1 FUSE435U5●	6/63		and 6/64
	to 6/23	AB1 BC15035	6/47	AB1 FUSE435U6X●	6/63	AB1 TC0●	6/69
AB1 AAET135UGR	6/18	AB1 BC24035	6/47	AB1 FU10●35U●●	6/67	AB1 TC3	6/69
AB1 AAET235UB	6/19	AB1 BC9535	6/46	AB1 L2ET	6/57	AB1 TE	6/57
AB1 AAET235UB●●	6/19	AB1 BCP20235U	6/55	AB1 NEN1●35U	6/51	AB1 TEN●	6/56
AB1 AAET235U●●	6/19	AB1 BD1	6/52	AB1 NEN435U	6/50	AB1 TF	6/67
AB1 AASC135U●●	6/20	AB1 BD10●	6/52	AB1 PC15	6/48	AB1 TM1N	6/60
AB1 AASC235U●●	6/21	AB1 BD53●	6/52		and 6/49		and 6/61
AB1 AASF135UGR	6/22	AB1 BE●	6/57	AB1 PC3	6/50, 6/51, 6/60	AB1 TNN1●	6/51
AB1 AASF235UGR	6/23	AB1 BF●	6/67		and 6/61	AB1 TNN4	6/50
AB1 AATP135U●	6/14	AB1 BL●●	6/36	AB1 PS4	6/62	AB1 TP1●35U	6/43
	and 6/15		and 6/37		and 6/64	AB1 TP215	6/49
AB1 AATP235U●	6/16	AB1 BV10235U	6/53	AB1 RR1035U2●●	6/27	AB1 TP3535U	6/43
	and 6/17	AB1 CA1●	6/37	AB1 RR1635U2●●	6/27	AB1 TP●35U	6/42
AB1 AB10M32	6/36 to	AB1 CA2	6/36	AB1 RR235U2●●	6/24	AB1 TRNN435	6/61
	6/39, 6/42, 6/43, 6/50		and 6/69	AB1 RR235U3●●	6/25	AB1 TRPN435	6/61
	to 6/67	AB1 CA215	6/48	AB1 RR235U4●●	6/25	AB1 TRPN435UFM	6/61
AB1 AB715	6/48	AB1 CA3●	6/39	AB1 RR435U2●●	6/25	AB1 TRSN435	6/60
	and 6/49		and 6/49	AB1 RR435U3●●	6/26	AB1 TV●	7/11
AB1 AB7P32	6/36 to	AB1 CA4	6/37	AB1 RR635U2●●	6/27	AB1 VV215●●	6/48
	6/39, 6/42, 6/43, 6/50		and 6/57	AB1 RRAC242●●	6/24	AB1 VV235U●●	6/36
	to 6/69	AB1 CA410ET	6/37, 6/57		and 6/25	AB1 VV415	6/49
	6/10 to		and 6/69	AB1 RRAC243●●	6/25	AB1 VV435U●●●	6/37
AB1 AB8●35	6/69	AB1 CA6	6/37	AB1 RRAC244●●	6/25	AB1 VV635U●●	6/37
	and 6/49	AB1 CC410●●	6/56		and 6/33	AB1 VVN1035U●●	6/37
AB1 AC2	6/48		and 6/62	AB1 RRAC443●●	6/26	AB1 VVN15035U●●	6/39
	and 6/49	AB1 CC42INFRO	6/57	AB1 RRAL1●2	6/27	AB1 VVN1635U●●	6/38
AB1 AC24●●	6/36	AB1 CC42●●	6/56	AB1 RRAL2●●	6/10 to	AB1 VVN3535U●●	6/39
	and 6/37		and 6/62		6/13, 6/18	AB1 VVN7035U●●	6/39
AB1 AC6●●	6/37	AB1 CC42SUPRO	6/57	AB1 RRAL4●●	6/25, 6/26	ABC 6HE20F	4/44
AB1 ACD2	6/58	AB1 CC4●SC	6/62		and 6/33	ABE 7ACC0●	4/43, 4/45
	and 6/59	AB1 CC46INFRO	6/57		and 6/34		and 4/46
AB1 ACN10	6/37	AB1 CC46SUPRO	6/57	AB1 RRAL62	6/27	ABE 7ACC1●	4/41
AB1 ACN16	6/38	AB1 CJ2	6/36	AB1 RRAS242●●	6/24		and 4/43
AB1 ACN16BL	6/38	AB1 CJ215	6/48		and 6/25	ABE 7ACC2●	4/43
AB1 AL16	6/38	AB1 CJ3	6/49	AB1 RRAS24●BL	6/25	ABE 7ACC30	4/43
AB1 AL2	6/36		and 6/56	AB1 RRCF03	6/33	ABE 7ACC8●	4/43
AB1 AL4	6/37, 6/56	AB1 CJ4	6/37	AB1 RRCS1●	6/27	ABE 7BV10●	4/43
	and 6/69	AB1 CJ6	6/37		and 6/31	ABE 7BV20●	4/43
		AB1 CJN1●	6/37			ABE 7CPA0●	4/42
			and 6/38			ABE 7CPA1●	4/42
						ABE 7CPA21	4/42
						ABE 7CPC31●	4/42
						ABE 7H08●●●	4/37
						ABE 7H12●●●	4/37
						ABE 7H16C●●	4/36
						ABE 7H16CM●●	4/36
						ABE 7H16F43	4/37
						ABE 7H16R1●●	4/37
						ABE 7H16R2●●	4/37
						ABE 7H16R3●●	4/37
						ABE 7H16R50●	4/37
						ABE 7H16S21●	4/37
						ABE 7H16S43	4/37
						ABE 7H20E●00	4/36
						ABE 7H32E●●0	4/36
						ABE 7LOGF25	4/43
						ABE 7LOGV10	4/43
						ABE 7P08T330●	4/40
						ABE 7P16F31●●	4/39
						ABE 7P16M111	4/40
						ABE 7P16T111	4/40
						ABE 7P16T21●	4/40
						ABE 7P16T230●	4/40
						ABE 7P16T318●	4/40
						ABE 7P16T330●	4/40
						ABE 7P16T33●	4/40
						ABE 7R08S111●	4/38
						ABE 7R08S210●	4/38
						ABE 7R08S216●	4/38
						ABE 7R16M111	4/39
						ABE 7R16S11●●	4/38
						ABE 7R16S210●	4/38
						ABE 7R16S212●	4/38
						ABE 7R16T111	4/39
						ABE 7R16T21●	4/39
						ABE 7R16T23●	4/39
						ABE 7R16T33●	4/39
						ABE 7R16T370	4/39
						ABE 7S08S2B0●	4/38
						ABE 7S08S2B1●	4/38
						ABE 7S16E2B1●	4/38
						ABE 7S16E2E0●	4/38
						ABE 7S16E2E1●	4/38
						ABE 7S16E2F0●	4/38
						ABE 7S16E2M0●	4/38
						ABE 7S16S1B2●	4/38
						ABE 7S16S2B0●	4/38
						ABE 7TES160	4/43
						ABE 9C1240C23	5/6
							and 5/7
						ABE 9C1240L●●	5/6
							and 5/7
						ABE 9C1240M	5/7
						ABE 9C1241C23	5/6
							and 5/7
						ABE 9C1241L●●	5/6
							and 5/7
						ABE 9C1241M	5/7
						ABE 9C1280C23	5/6
							and 5/7
						ABE 9C1280L●●	5/7
						ABE 9C1280M	5/7
						ABE 9C1281C23	5/6
							and 5/7
						ABE 9C1281L●●	5/6
							and 5/7
						ABE 9C1281M	5/7
						ABE 9CM12C	5/7
						ABE 9XCA14●●	5/7
						ABE 9XCA18●●	5/7
						ABE 9XLA10	5/7
						ABF A32H151	4/47
						ABF A32H200	4/47
						ABF A32H30●	4/47

Product reference index

ABF B25S01	4/45	ABL 7RM1202	1/7	AZ5 CE005●	7/6	DZ5 CE0253●	7/6	FTX DG12	5/28
ABF B50S01	4/45	ABL 7RM2401	1/7	and 7/8	and 7/8	and 7/8	and 7/8	and 5/47	and 5/47
ABF C08R02●	3/8, 3/14	ABL 7RP1205	1/17	AZ5 CE007●	7/6	DZ5 CE042●	7/6	FTX DP12●●	5/27
	and 4/43	ABL 7RP240●	1/17	and 7/8	and 7/8	and 7/8	and 7/8	and 5/46	and 5/46
ABF C08R12●	3/8, 3/14	ABL 7RP2410	1/17	AZ5 CE010●	7/6	DZ5 CE043●	7/6	FTX DP12●5	5/27
	and 4/43	ABL 7RP4803	1/17	and 7/8	and 7/8	and 7/8	and 7/8	and 5/47	and 5/47
ABF C20R200	4/44	ABL 7UEQ24100	1/17	AZ5 CE015●	7/6	DZ5 CE062●	7/6	FTX DP21●●	5/27
ABF F25S200	4/44	ABL 7UEQ24200	1/17	and 7/8	and 7/8	and 7/8	and 7/8	and 5/47	and 5/47
	and 4/51	ABL 7UES24050	1/17	AZ5 CE025●	7/6	DZ5 CE063●	7/6	FTX DP22●●	5/27
ABF H14H150	4/51	ABL 7UPS24100	1/17	and 7/8	and 7/8	and 7/8	and 7/8	and 5/47	and 5/47
ABF H14H300	4/51	ABL 7UPS24200	1/17	AZ5 DE007●	7/6 to 7/8	DZ5 CEB005●	7/6	FTX DP32●●	5/27
ABF H16H150	4/51	ABL 7UPS24400	1/17	AZ5 DE010●	7/6 to 7/8	and 7/8	and 7/8	and 5/46	and 5/46
ABF H16H300	4/51	ABR 1E101M	3/8	AZ5 DE015●	7/6 to 7/8	DZ5 CEB007●	7/6	FTX DP12L12	5/27
ABF H20H100	4/44	ABR 1E111●	3/8	AZ5 DE025●	7/6 to 7/8	and 7/8	and 7/8	and 5/47	and 5/47
ABF H20H151	4/45	ABR 1E112F	3/8			DZ5 CEB010●	7/6	FTX ES00	5/28
ABF H20H20●	4/44	ABR 1E118●	3/8			and 7/8	and 7/8	and 5/47	and 5/47
	and 4/45	ABR 1E301M	3/8	D		DZ5 CEB015●	7/6	FTX IB12●●	5/27
ABF H20H300	4/44	ABR 1E311●	3/8	DB6 CD02	6/40	and 7/8	and 7/8	FTX MLA10	5/28
	and 4/45	ABR 1E312F	3/8	DB6 CD1●●	6/40	DZ5 CEB025●	7/6	and 5/47	and 5/47
ABF H20H501	4/45	ABR 1E312F	3/8	DB6 DD10●	6/41				
ABF H28H150	4/51	ABR 1E318●	3/8	DB6 ED0●	6/41				
ABF H28H300	4/51	ABR 1E411●	3/8	DB6 FD0●	6/41				
ABF H32H150	4/51	ABR 1E412F	3/8	DZ5 CA00●●	7/7				
ABF H32H300	4/51	ABR 1E418●	3/8	and 7/9	and 7/9	F			
ABF H34H100	4/45	ABR 1S102B	3/8	DZ5 CA01●●	7/7	FTB 1CN08E08SP0	5/26	RSB 1A120●●	2/5
ABF H34H200	4/45	ABR 1S111F	3/8	and 7/9	and 7/9	FTB 1CN12E04SP0	5/26	RSB 1A160●●	2/5
ABF H34H300	4/45	ABR 1S118●	3/8	DZ5 CA025●	7/7	FTB 1CN16●P0	5/26	RSB 2A080●●	2/5
ABF H40H15●	4/50	ABR 1S302B	3/8	and 7/9	and 7/9	FTB 1DN08E08CM0	5/26	RSZ E1S35M	2/5
ABF H40H30●	4/50	ABR 1S311F	3/8	DZ5 CA042●	7/7	FTB 1DN08E08SP0	5/26	RSZ E1S48M	2/5
ABF M04S20●	4/49	ABR 1S318●	3/8	and 7/9	and 7/9	FTB 1DN12E04SP0	5/26	RSZ L300	2/5
ABF M08S20●	4/49	ABR 1S402B	3/8	DZ5 CA043	7/7	FTB 1DN16C●0	5/26	RSZ R215	2/5
ABF M16H15●	4/48	ABR 1S411F	3/8	DZ5 CA062●	7/7	FTB 1DN16E●0	5/26	RZM 021●●	2/5
ABF M16H30●	4/48	ABR 1S418●	3/8	and 7/9	and 7/9	FTB 1DP08E08CM0	5/26	RZM 031BN	2/5
ABF M16S201	4/49	ABR 1S602B	3/8	DZ5 CA063	7/7	FTB 1DP08E08SP0	5/26	RZM 031FPD	2/5
ABF M32H15●	4/49	ABR 1S611F	3/8	DZ5 CA102●	7/7	FTB 1DP12E04SP0	5/26	RZM 040W	2/5
ABF M32H30●	4/49	ABR 1S618●	3/8	and 7/9	and 7/9	FTB 1DP16C●0	5/26	RZM 041BN7	2/5
ABF R16H20●	4/50	ABR 2E111M	3/14	DZ5 CA103●	7/7	FTB 1DP16E●0	5/26	RZM 041FU7	2/5
ABF S08H20●	4/51	ABR 2E112●	3/14	and 7/9	and 7/9	FTB 1IB08E08SP1	5/26		
ABF S16H200	4/51	ABR 2E115F	3/14	DZ5 CA162●	7/7	FTB 1IB12E04SP1	5/26		
ABF S24H200	4/51	ABR 2E116F	3/14	and 7/9	and 7/9	FTB 1IB16●P1	5/26	T	
ABF S25S30●	4/45	ABR 2EB312B	3/14	DZ5 CA163●	7/7	FTM 1AE04C12●	5/46	TLX L FBC M	5/28
	and 4/47	ABR 2S1●2B	3/14	and 7/9	and 7/9	FTM 1AS04C12●	5/46	and 5/47	and 5/47
ABF Y25S200	4/44	ABR 7S11	4/41	DZ5 CA253●	7/7	FTM 1CN10	5/46	TSX BLK ●1	4/45
ABL 6AM0●	1/27	ABR 7S2●	4/41	and 7/9	and 7/9	FTM 1DD08C08●	5/46	TSX CAP 030	4/44
	and 1/34	ABR 7S33●	4/41	DZ5 CA352●	7/7	FTM 1DD08C12●	5/46	TSX CCP ●15	4/44
ABL 6RF2401●●	1/27	ABR 7S37	4/41	and 7/9	and 7/9	FTM 1DD16C12●	5/46	TSX CDP 103	4/44
ABL 6RF2402●●	1/27	ABS 2EA01E●	3/20	DZ5 CA353●	7/7	FTM 1DE08C08●	5/46	TSX CDP 203	4/44
ABL 6RF2405●●	1/27	ABS 2EA02E●	3/20	and 7/9	and 7/9	FTM 1DE08C12●	5/46	TSX CDP 30●	4/44
ABL 6RF24●●	1/27	ABS 2EC01E●	3/20	DZ5 CA502●	7/7	FTM 1DE16C12●	5/46	TSX CDP 50●	4/44
ABL 6TD02●	1/34	ABS 2SA0●MB	3/20	and 7/9	and 7/9	FTM 1D●10	5/46	TSX CXP 213	4/44
ABL 6TD04●	1/34	ABS 2SC0●EB	3/20	DZ5 CA503●	7/7	FTX BLA10	5/28	TSX CXP 613	4/44
ABL 6TD06●	1/34	ABS 7EA3●5	4/41	and 7/9	and 7/9	FTX C78●●	5/28	TSX PBSCA100	5/27
ABL 6TD100●	1/34	ABS 7EC3AL	4/41	DZ5 CE002●●	7/6	and 5/47	and 5/47	TSX PBSCA400	5/27
ABL 6TD10●	1/34	ABS 7EC3●2	4/41	DZ5 CE003●●	7/6	FTX CA31●●	5/47		
ABL 6TD160●	1/34	ABS 7SA2M	4/41	DZ5 CE005●	7/6	FTX CA32●●	5/47		
ABL 6TD16●	1/34	ABS 7SA3MA	4/41	and 7/8	and 7/8	FTX CB32●●	5/47		
ABL 6TD250●	1/34	ABS 7SC1B	4/41	DZ5 CE005L12●	7/6	FTX CBTL12	5/47		
ABL 6TD25●	1/34	ABS 7SC2E	4/41	and 7/8	and 7/8	FTX CM08B	5/7, 5/28		
ABL 6TD40●	1/34	ABS 7SC3BA	4/41	DZ5 CE005L6●	7/6	and 5/47	and 5/47		
ABL 6TD63●	1/34	ABS 7SC3E	4/41	and 7/8	and 7/8	FTX CM12B	5/6, 5/7,		
ABL 6TS02●	1/34	AM1 PA●	6/52	DZ5 CE007●	7/6	and 5/28	and 5/28		
ABL 6TS04●	1/34	AR1 MA01	7/9	and 7/8	and 7/8	FTX CN12F5	5/27		
ABL 6TS06●	1/34	AR1 MB01	7/9	DZ5 CE007L6●	7/6	and 5/46	and 5/46		
ABL 6TS100●	1/34	AR1 MC01●	7/9	and 7/8	and 7/8	FTX CN12M5	5/27		
ABL 6TS10●	1/34	AR1 SB3	1/27, 1/34	DZ5 CE010●	7/6	and 5/46	and 5/46		
ABL 6TS160●	1/34	and 4/43	and 4/43	and 7/8	and 7/8	FTX CN32●●	5/27		
ABL 6TS16●	1/34	AR1 SC0●	7/9	DZ5 CE010L12●	7/6	and 5/46	and 5/46		
ABL 6TS250●	1/34	AR2 XA335983	6/41	and 7/8	and 7/8	FTX CNCT1	5/27		
ABL 6TS25●	1/34	AT1 HB2	7/11	DZ5 CE010L6●	7/6	and 5/47	and 5/47		
ABL 6TS40●	1/34	AT1 PA●	7/10	and 7/8	and 7/8	FTX CNTL12	5/27		
ABL 6TS63●	1/34	and 7/11	and 7/11	DZ5 CE015	7/6	and 5/46	and 5/46		
ABL 7CEM240●●	1/17	AT1 PS1	7/11	DZ5 CE0153●	7/6	FTX CPE10	5/27		
ABL 7RE240●	1/17	AT2 PA●	7/10	and 7/8	and 7/8	FTX CY1208	5/7, 5/28		
ABL 7RE2410	1/17	AT2 PB1	7/11	DZ5 CE015D	7/8	and 5/47	and 5/47		
ABL 7REQ24050	1/17	AT2 PE1	7/10	DZ5 CE015L6●	7/6	FTX CY1212	5/6, 5/7,		
ABL 7REQ24100	1/17	AT2 PT●	7/11	and 7/8	and 7/8	and 5/28	and 5/28		
		AT2 TRIF01	7/10	DZ5 CE02●	7/6	and 5/47	and 5/47		

Technical information

Protective treatment according to climatic environment

Depending on the climatic and environmental conditions in which the equipment is placed, Schneider Electric can offer specially adapted products to meet your requirements.

In order to make the correct choice of protective finish, two points should be remembered :

- The prevailing climate of the country is never the only criterion.
- Only the atmosphere in the immediate vicinity of the equipment need be considered.

All climates treatment "TC"

This is the standard treatment for the Telemecanique brand equipment and is suitable for the vast majority of applications.

It is the equivalent of treatments described as "Klimafest", "Climateproof", "Total tropicalisation" or "Super tropicalisation" and meets the same requirements, in particular :

- Publication UTE C 63-100 (method I), successive cycles of humid heat at :
+ 40 °C and 95 % relative humidity.
- DIN 50016 - Variations of ambient conditions within a climatic chamber :
+ 23 °C and 83 % relative humidity,
+ 40 °C and 92 % relative humidity.

It also meets the requirements of the following marine classification authorities : BV-LROS-GL-DNV-RINA.

Characteristics

- Steel components are usually treated with zinc chromate and, when they have a mechanical function, they may also be painted.
- Insulating materials are selected for their high electrical, dielectric and mechanical characteristics.
- Metal enclosures have a stoved paint finish, applied over a primary phosphate protective coat, or are galvanised (e.g. some prefabricated busbar trunking components).

Limits for use of "TC" (All climates) treatment

- "TC" treatment is suitable for the following temperatures and humidity :

Temperature	(°C)	20	40	50
Relative humidity	(%)	95	80	50

- It may also be used where the above limits are only exceeded accidentally or for very short periods, or where temperature variations are not sufficient or fast enough to cause heavy condensation or dripping water on the equipment.
"TC" treatment is therefore suitable for all latitudes, including tropical and equatorial regions, where the equipment is mounted in normal, ventilated industrial locations. Being sheltered from external climatic conditions, temperature variations are small, the risk of condensation is minimised and the risk of dripping water is virtually non-existent.

Extension of use of "TC" (All climates) treatment

In cases where the humidity around the equipment exceeds the conditions described above, where the equipment, in tropical regions, is mounted outdoors, or where it is placed in a very humid location (laundries, sugar refineries, steam rooms, etc.), "TC" treatment can still be used if the following precautions are taken :

- The enclosure in which the equipment is mounted must be protected with a "TH" finish (see next page) and must be well ventilated to avoid condensation and dripping water (e.g. enclosure base plate mounted on spacers).
- Components mounted inside the enclosure must have a "TC" finish.
- If the equipment is to be switched off for long periods, a heater must be provided (0.2 to 0.5 kW per square decimetre of enclosure), switched on automatically when the equipment is turned off. This heater keeps the inside of the enclosure at a temperature slightly higher than the outside surrounding temperature, thereby avoiding any risk of condensation and dripping water (the heat produced by the equipment itself in normal running is sufficient to provide this temperature difference).
- For pilot devices, the use of "TC" treatment can be extended to outdoor use provided the enclosure is made of light alloys, zinc alloys or plastic material. In this case, it is essential to ensure that the degree of protection against penetration of liquids and solid objects is suitable for the applications involved.

Technical information

Protective treatment according to climatic environment

“TH” treatment for hot and humid environments

This treatment is for hot and humid atmospheres where installations are subject to condensation, dripping water and the risk of fungi.

Plastic insulating components are also resistant to attacks from insects such as termites and cockroaches. These properties have led to this treatment being described as “Tropical Finish”, but this does not mean that all equipment installed in tropical and equatorial regions must systematically have undergone “TH” treatment. On the other hand, certain operating conditions in temperate climates may well require the use of “TH” treated equipment (see limitations for use of “TC” treatment).

Special characteristics of “TH” treatment

- All insulating components are made of materials which are either resistant to fungi or treated with a fungicide, and which have increased resistance to creepage (Standards IEC 112, NF C 26-220, DIN 5348).
- Metal enclosures receive a top-coat of stoved, fungicidal paint, applied over a rust inhibiting undercoat. Components with “TH” treatment may be subject to a surcharge (1). Please consult your Regional Sales Office.

(1) A large number of the Telemecanique brand products are “TH” treated as standard and are, therefore, not subject to a surcharge.

Protective treatment selection guide

Location	Environmental conditions	Duty cycle	Internal heating of enclosure when not in use	Type of climate	Protective treatment of components of enclosure	
Indoors	No dripping water or condensation	Unimportant	Unnecessary	Unimportant	“TC”	“TC”
	Presence of dripping water or condensation	Frequent switching off for periods of more than 1 day	No	Temperate	“TC”	“TH”
			Yes	Equatorial	“TH”	“TH”
		Continuous	Unnecessary	Unimportant	“TC”	“TH”
Outdoors (sheltered)	No dripping water or dew	Unimportant	Unnecessary	Temperate	“TC”	“TC”
	Exposed outdoors or near the sea	Frequent and regular presence of dripping water or dew	No	Equatorial	“TH”	“TH”
Yes			Unimportant	“TC”	“TH”	
Continuous		Unnecessary	Unimportant	“TC”	“TH”	

These treatments cover, in particular, the applications defined by methods I and II of guide UTE C 63-100.

Special precautions for electronic equipment

Electronic products always meet the requirements of “TC” treatment. A number of them are “TH” treated as standard.

Some electronic products (for example : programmable controllers, flush mountable controllers CCX and flush mountable operator terminals XBT) necessitate the use of an enclosure providing a degree of protection to at least IP 54, as defined by the standards IEC 664 and NF C 20 040, for use in industrial applications or in environmental conditions requiring a “TH” treatment.

These electronic products, including flush mountable products, must have a degree of protection to at least IP 20 (either provided by the enclosure itself or following installation) for restricted access locations where the degree of pollution does not exceed 2 (a test booth not containing machinery or other dust producing activities, for example).

Special treatments

For highly corrosive industrial environments, Schneider Electric is able to offer special protective treatments. Please consult your Regional Sales Office.

Technical information

Product standards and approvals

Standardisation

Conformity to standards

The Telemecanique brand products satisfy, in the majority of cases, national (for example: BS in Great Britain, NF in France, DIN in Germany), European (for example: CENELEC) or international (IEC) standards. These product standards precisely define the performance of the designated products (such as IEC 60947 for low voltage equipment). When used correctly, as designated by the manufacturer and in accordance with regulations and correct practices, these products will allow assembled equipment, machine systems or installations to conform to their appropriate standards (for example: IEC 60204, relating to electrical equipment used on industrial machines).

Schneider Electric is able to provide proof of conformity of its production to the standards it has chosen to comply with, through its quality assurance system.

On request, and depending on the situation, Schneider Electric can provide the following:

- a declaration of conformity,
- a certificate of conformity (ASEFA/LOVAG),
- an approval certificate or agreement, in the countries where this procedure is required or for particular specifications, such as those existing in the merchant navy.

Code	Standards body Name	Abbreviation	Country
ANSI	American National Standards Institute	ANSI	USA
BS	British Standards Institution	BSI	Great Britain
CEI	Comitato Elettrotecnico Italiano	CEI	Italy
DIN/VDE	Verband Deutscher Elektrotechniker	VDE	Germany
EN	Comité Européen de Normalisation Electrotechnique	CENELEC	Europe
GOST	Gosudarstvennoe Komitet Standartov	GOST	Russia
IEC	International Electrotechnical Commission	IEC	Worldwide
JIS	Japanese Industrial Standard	JISC	Japan
NBN	Institut Belge de Normalisation	IBN	Belgium
NEN	Nederlands Normalisatie Instituut	NNI	Netherlands
NF	Union Technique de l'Electricité	UTE	France
SAA	Standards Association of Australia	SAA	Australia
UNE	Asociacion Española de Normalizacion y Certificacion	AENOR	Spain

European EN standards

These are technical specifications established in conjunction with, and with approval of, the relative bodies within the various CENELEC member countries (European Union, European Free Trade Association and many central and eastern European countries having «member» or «affiliated» status). Arrived at through the principle of consensus, the European standards are the result of a weighted majority vote. Such adopted standards are then integrated into the national collection of standards, and contradictory national standards are withdrawn.

The European standards are now incorporated within the French standards and carry the prefix NF EN. Under the "Technical Union of Electricity" (UTE), the French version of the corresponding European standard carries a double notation: European reference (NF EN ...) and classification (C ...).

Therefore, the standard NF EN 60947-4-1 relating to motor contactors and starters, effectively constitutes the French version of the European standard EN 60947-4-1 and carries the UTE classification C 63-110.

This standard is identical to the British standard BS EN 60947-4-1 or the German standard DIN EN 60947-4-1.

Whenever reasonably practical, European standards reflect the international standards (IEC).

With regard to automation system components and distribution equipment, in addition to complying with the requirements of French NF standards, Telemecanique brand components conform to the standards of all other major industrial countries.

Regulations

European Directives

Opening up of European markets assumes harmonisation of the regulations pertaining to each member country of the European Union.

The purpose of the European Directive is to eliminate obstacles hindering the free circulation of goods within the European Union, and it applies to each member country. Member countries are obliged to transcribe each Directive into their national legislation and to simultaneously withdraw any contradictory regulations. The Directives, in particular those of a technical nature which concern us, only establish the objectives to be achieved and are referred to as "essential requirements".

The manufacturer must take all the necessary measures to ensure that his products conform to the requirements of each Directive applicable to his production.

As a general rule, the manufacturer certifies conformity to the essential requirements of the Directive(s) for his product by affixing a CE mark.

The CE mark is affixed to Telemecanique brand products, as defined by French and European regulations.

Significance of the CE mark

- The CE mark affixed to a product signifies that the manufacturer certifies that the product conforms to the relevant European Directive(s) which concern him ; this condition must be met to allow free distribution and circulation within the countries of the European Union of any product subject to one or more of the E.U. Directives.
- The CE mark is intended solely for national market control authorities.
- The CE mark must not be confused with a conformity marking.

Technical information

Product standards and approvals

European Directives (continued)

For electrical equipment, only conformity to standards signifies that the product is suitable for its designated function, and only the guarantee of an established manufacturer can provide a high level of quality assurance.

For Telemecanique brand products, one or several Directives are likely to be applicable, depending on the product, in particular:

- the Low Voltage Directive 73/23/EEC amended by Directive 93/68/EEC: the CE mark relating to this Directive has been compulsory since 1st January 1997.

- the Electromagnetic Compatibility Directive 89/336/EEC, amended by Directives 92/31/EEC and 93/68/EEC: the CE mark on products covered by this Directive has been compulsory since 1st January 1996.

ASEFA-LOVAG certification

The function of ASEFA (Association des Stations d'Essais Française d'Appareils électriques - *Association of French Testing Stations for Low Voltage Industrial Electrical Equipment*) is to carry out tests of conformity to standards and to issue certificates of conformity and test reports. ASEFA laboratories are authorised by the French authorisation committee (COFRAC).

ASEFA is now a member of the European accord group LOVAG (Low Voltage Agreement Group). This means that any certificates issued by LOVAG/ASEFA are recognised by all the authorities forming the membership of the group and carry the same validity as those issued by any of the member authorities.

Quality labels

When components can be used in domestic and similar applications, it is sometimes recommended that a "Quality label" be obtained, which is a form of certification of conformity.

Code	Quality label	Country
CEBEC	Comité Electrotechnique Belge	Belgium
KEMA-KEUR	Keuring van Electrotechnische Materialen	Netherlands
NF	Union Technique de l'Electricité	France
ÖVE	Österreichischer Verband für Electrotechnik	Austria
SEMKO	Svenska Electriska Materiel Kontrollnataalten	Sweden

Approvals

In some countries, the approval of certain electrical equipment is required by law or by the market. In this case, an approval certificate is issued by the official test authority.

Each approved component must bear the relevant quality label when this is mandatory:

Code	Approval authority	Country
CSA	Canadian Standards Association	Canada
UL	Underwriters Laboratories	USA

Note on approvals issued by the Underwriters Laboratories (UL). There are two levels of approval:

"Recognized" (R) The component is fully approved for inclusion in equipment built in a workshop, where the operating limits are known by the equipment manufacturer and where its use within such limits is acceptable by the Underwriters Laboratories.

The component is not approved as a "Product for general use" because its manufacturing characteristics are incomplete or its application possibilities are limited.

A "Recognized" component does not necessarily carry the approval symbol.

"Listed" (UL)

The component conforms to all the requirements of the classification applicable to it and may therefore be used both as a "Product for general use" and as a component in assembled equipment.

A "Listed" component must carry the approval symbol.

Marine classification authorities

Prior approval by certain marine classification authorities is generally required for electrical equipment which is intended for use on board merchant vessels.

Code	Classification authority	Country
BV	Bureau Veritas	France
DNV	Det Norske Veritas	Norway
GL	Germanischer Lloyd	Germany
LROS	Lloyd's Register of Shipping	Great Britain
NKK	Nippon Kaiji Kyokai	Japan
RINA	Registro Italiano Navale	Italy
RRS	Register of Shipping	Russia

Note

For further details on a specific product, please refer to the "Characteristics" pages in this catalogue or consult your Regional Sales Office.

Technical information

Degrees of protection provided by enclosures

Degrees of protection against the penetration of solid bodies, water and personnel access to live parts

The European standard EN 60529 dated October 1991, IEC publication 529 (2nd edition - November 1989), defines a coding system (IP code) for indicating the degree of protection provided by electrical equipment enclosures against accidental direct contact with live parts and against the ingress of solid foreign objects or water. This standard does not apply to protection against the risk of explosion or conditions such as humidity, corrosive gasses, fungi or vermin.

Certain equipment is designed to be mounted on an enclosure which will contribute towards achieving the required degree of protection (example : control devices mounted on an enclosure).

Different parts of an equipment can have different degrees of protection (example : enclosure with an opening in the base).

Standard NF C 15-100 (May 1991 edition), section 512, table 51 A, provides a cross-reference between the various degrees of protection and the environmental conditions classification, relating to the selection of equipment according to external factors.

Practical guide UTE C 15-103 shows, in the form of tables, the characteristics required for electrical equipment (including minimum degrees of protection), according to the locations in which they are installed.















IP ●●● code

The IP code comprises 2 characteristic numerals (e.g. IP 55) and may include an additional letter when the actual protection of personnel against direct contact with live parts is better than that indicated by the first numeral (e.g. IP 20C).

Any characteristic numeral which is unspecified is replaced by an X (e.g. IP XXB).

1st characteristic numeral : corresponds to protection of the equipment against penetration of solid objects and protection of personnel against direct contact with live parts.

2nd characteristic numeral : corresponds to protection of the equipment against penetration of water with harmful effects.

	Protection of the equipment	Protection of personnel		Protection of the equipment	Protection of personnel
0	Non-protected	Non-protected	0	Non-protected	
1	 $\varnothing 50 \text{ mm}$ Protected against the penetration of solid objects having a diameter greater than or equal to 50 mm.	Protected against direct contact with the back of the hand (accidental contacts).	1	 Protected against vertical dripping water, (condensation).	
2	 $\varnothing 12,5 \text{ mm}$ Protected against the penetration of solid objects having a diameter greater than or equal to 12.5 mm.	Protected against direct finger contact.	2	 15° Protected against dripping water at an angle of up to 15°.	
3	 $\varnothing 2,5 \text{ mm}$ Protected against the penetration of solid objects having a diameter greater than or equal to 2.5 mm.	Protected against direct contact with a $\varnothing 2.5 \text{ mm}$ tool.	3	 60° Protected against rain at an angle of up to 60°.	
4	 $\varnothing 1 \text{ mm}$ Protected against the penetration of solid objects having a diameter > 1 mm.	Protected against direct contact with a $\varnothing 1 \text{ mm}$ wire.	4	 Protected against splashing water in all directions.	
5	 Dust protected (no harmful deposits).	Protected against direct contact with a $\varnothing 1 \text{ mm}$ wire.	5	 Protected against water jets in all directions.	
6	 Dust tight.	Protected against direct contact with a $\varnothing 1 \text{ mm}$ wire.	6	 Protected against powerful jets of water and waves.	
			7	 15 cm min. Protected against the effects of temporary immersion.	
			8	 1 m Protected against the effects of prolonged immersion under specified conditions.	

Degrees of protection against mechanical impact

The European standard EN 50102 dated March 1995 defines a coding system (IK code) for indicating the degree of protection provided by electrical equipment enclosures against external mechanical impact. Standard NF C 15-100 (May 1991 edition), section 512, table 51 A, provides a cross-reference between the various degrees of protection and the environmental conditions classification, relating to the selection of equipment according to external factors. Practical guide UTE C 15-103 shows, in the form of tables, the characteristics required for electrical equipment (including minimum degrees of protection), according to the locations in which they are installed.

Additional letter : corresponds to protection of personnel against direct contact with live parts.

IK ●● code

The IK code comprises 2 characteristic numerals (e.g. IK 05).

2 characteristic numerals : corresponding to a value of impact energy.

A	With the back of the hand.
B	With the finger.
C	With a Ø 2.5 mm tool.
D	With a Ø 1 mm wire.

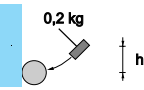
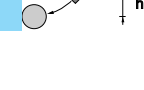
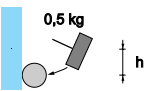
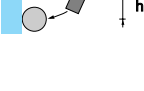
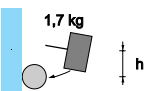
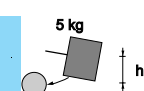
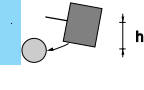
		h (cm)	Energy (J)
00	Non-protected		
01		7.5	0.15
02		10	0.2
03		17.5	0.35
04		25	0.5
05		35	0.7
06		20	1
07		40	2
08		30	5
09		20	10
10		40	20



Schneider Electric worldwide

Up-dated: 28-07-2003

Afghanistan	Contacts are assured by	Schneider Electric India		
Albania	Contacts are assured by	Schneider Electric Austria		
Algeria	■ Schneider Electric	voie A Lot C22 Zone Industrielle Rouiba - Alger	Tel. : +213 21 92 97 02 à 09 Fax : +213 21 92 97 00 à 01	
Andorra	Contacts are assured by	Schneider Electric France		
Angola	Contacts are assured by	Schneider Electric South Africa		
Anguilla	Contacts are assured by	Schneider Electric Dominican Rep.		
Antartica	Contacts are assured by	Schneider Electric Brazil		
Antigua & Barbuda	Contacts are assured by	Schneider Electric Dominican Rep.		
Argentina	■ Schneider Argentina	Viamonte 2850 - 1678 Caseros (provincia Buenos Aires)	Tel.: +54 1 716 88 88 Fax: +54 1 716 88 33	www.schneider-electric.com.ar
Armenia	Contacts are assured by	Schneider Electric Russian Fed.		
Aruba	Contacts are assured by	Schneider Electric Dominican Rep.		
Australia	■ Schneider Electric (Australia) Pty. Limited	2 Solent Circuit Norwest Business Park Baulkham Hill _ NSW 2153	Tel.: +61 298 51 28 00 Fax: +61 296 29 83 40	www.schneider.com.au
Austria	■ Schneider Austria Ges.m.b.H.	Birostrasse 11 1239 Wien	Tel.: +431 610 540 Fax: +431 610 54 54	www.schneider-electric.at
Azerbaijan	Contacts are assured by	Schneider Electric Russian Fed.		
Bahamas	■ Schneider Electric	Union Village PO Box 3901 - Nassau	Tel. : +1 242 327 42 91 Fax : +1 242 327 42 91	www.squared.com
Bahrain	■ Schneider Electric	Floor 1 - Juma Building Abu Horalra Avenue PO Box 355 - 304 Manama	Tel.: +97 322 7897 Fax: +97 321 8313	
Bangladesh	Contacts are assured by	Schneider Electric India		
Barbados	Contacts are assured by	Schneider Electric Dominican Rep.		
Belarus	■ Schneider Electric Industries SA	Prospect Macherova 5, of. 202 220004 Minsk	Tel. : +375 172 23 75 50 Fax : +375 172 23 97 61	
Belgium	■ Schneider Electric nv/sa	Dieweg 3 B - 1180 Brussels	Tel.: +3223737711 Fax: +3223753858	www.schneider-electric.be
Belze	Contacts are assured by	Schneider Electric USA		
Benin	Contacts are assured by	Schneider Electric Ivory Coast		
Bermuda	Contacts are assured by	Schneider Electric Dominican Rep.		
Bhutan	Contacts are assured by	Schneider Electric India		
Bolivia	Contacts are assured by	Schneider Electric Chile		
Bosnia and Herzegovina	Contacts are assured by	Schneider Electric Croatia		
Botswana	Contacts are assured by	Schneider Electric South Africa		
Bouvet Island	Contacts are assured by	Schneider Electric Dominican Rep.		
Brazil	■ Schneider Electric Brazil Ltda.	Avenida Das Nações Unidas 23223 Jurubatuba - CEP 04795-907 São Paulo-SP	Tel.: +55 55 24 52 33 Fax: +55 55 22 51 34	www.schneider-electric.com.br
Brunel (Darussalam)	Contacts are assured by	Schneider Electric Singapore		
Bulgaria	■ Schneider Electric	Expo 2000, Boulevard Vapzarov 1407 Sofiav	Tel.: +3592 919 42 Fax: +3592 962 44 39	www.schneiderelectric.bg
Burkina Faso	Contacts are assured by	Schneider Electric Ivory Coast		
Burundi	Contacts are assured by	Schneider Electric Kenya		
Cambodia	Contacts are assured by	Schneider Electric Viet Nam		
Cameroon	■ Schneider Electric Cameroon	166, rue de l'Hôtel de Ville BP12087 - Douala	Tel.: +237 343 38 84 Fax: +237 343 11 94	
Canada	■ Schneider Canada	19, Waterman Avenue M4 B1Y2 Toronto - Ontario	Tel.: +1 416 752 8020 Fax: +1 416 752 4203	www.schneider-electric.ca
Cape Verde	Contacts are assured by	Schneider Electric Senegal		
Caribee	Contacts are assured by	Schneider Electric Dominican Rep.		
Cayman Islands	Contacts are assured by	Schneider Electric Dominican Rep.		
Central African Republic	Contacts are assured by	Schneider Electric Cameroon		
Chad	Contacts are assured by	Schneider Electric Cameroon		
Chile	■ Schneider Electric Chile S.A.	Avda. Pdtte Ed. Frei Montalva, 6001-31 Conchal - Santiago	Tel.: +56 2 444 3000 Fax: +56 2 423 9335	www.schneider-electric.co.cl
China	■ Schneider Beijing	Landmark bldg-Room 1801 8 North Dong Sanhuan Rd Chaoyang District 100004 Beijing	Tel.: +86 10 65 90 69 07 Fax: +86 10 65 90 00 13	www.schneider-electric.com.cn



Schneider Electric worldwide

Up-dated: 28-07-2003

Christmas Island	Contacts are assured by	Schneider Electric Australia		
Cocos (Keelling) Islands	Contacts are assured by	Schneider Electric Australia		
Colombia	■ Schneider Electric de Colombia S.A.	Calle 45A #102-48 Bogota DC	Tel.: +57 1 426 97 00 Fax: +57 1 426 97 40	
Comoros	Contacts are assured by	Schneider Electric la Reunion		
Congo	Contacts are assured by	Schneider Electric Cameroon		
Cook Islands	Contacts are assured by	Schneider Electric Australia		
Costa Rica	■ Schneider Centroamérica Ltda.	1.5 kms oeste de la Embajada Americana, Pavas, San José, Costa Rica C.A. Apartado: 4123-1000 San Jose	Tel.: +506 232-60-55 Fax: +506 232-04-26	www.schneider-ca.com
Croatia	■ Schneider Electric SA	Fallerovo Setaliste 22 HR - 10000 Zagreb	Tel.: +385 1 367 100 Fax: +385 1 367 111	
Cuba	■ Schneider Electric	Bureau de Liaison de La Havane Calle 36- N°306-Apto1 Entre 3ra y 5ta Avenida Miramar Playa Habana	Tel.: +53 724 15 59 Fax: +53 724 12 17	
Cyprus	■ Schneider Electric Cyprus	28 General Timayia Avenue Kyriakos Building, Block #A301 Larnaca 6046	Tel.: +00357 248 12646 Fax: +00357 246 37382	
Czech Republic	■ Schneider Electric CZ, s.r.o.	Thámovna 13 Praha 8 - 186 00	Tel.: +420 2 810 88 111 Fax: +420 2 24 81 08 49	www.schneider-electric.cz
Democratic Rep. of Congo	Contacts are assured by	Schneider Electric Cameroon		
Denmark	■ Schneider Electric A/S	Baltorpbakken 14 DK-2750 Ballerup	Tel.: +45 44 73 78 88 Fax: +45 44 68 5255	www.schneider-electric.dk
Djibouti	Contacts are assured by	Schneider Electric Egypt		
Dominican Republic	■ Schneider Electric	Calle Jacinto Manon Esq. Federico Geraldino Edificio D' Roca Plaza Suite 402, Ens. Paraiso - Santo Domingo	Tel.: +1 809 334 66 63 Fax: +1 809 334 66 68	
Ecuador	■ Schneider Electric Ecuador SA	Av.Republica del Salvador 1082 y Nac Edificio Mansion Blanca-Quito	Tel. : +593 2 224 42 42 Fax : +593 2 224 42 94	
Egypt	■ Schneider Electric Egypt sae	68, El Tayaran Street Nasr City, 11371 - Cairo	Tel.: +20 24 01 01 19 Fax: +20 24 01 66 87	www.schneider.com.eg
El Salvador	Contacts are assured by	Schneider Electric USA		
Equatorial Guinea	Contacts are assured by	Schneider Electric Cameroon		
Eritrea	Contacts are assured by	Schneider Electric Egypt		
Estonia	■ Lexel Electric	Ehitajate tee 110 EE 12618 Tallinn	Tel. : +372 650 97 00 Fax : +372 650 97 22	
Ethiopia	Contacts are assured by	Schneider Electric Egypt		
Falkland Islands	Contacts are assured by	Schneider Electric Brazil		
Faroe Islands	Contacts are assured by	Schneider Electric Australia		
Fiji	Contacts are assured by	Schneider Electric Australia		
Finland	■ Schneider Electric Oy	Sinimäentie 14 02630 Espoo	Tel. : +358 9 527 000 Fax : +358 9 5270 0376	www.schneider-electric.fi
France	■ Schneider Electric SA	5, rue Nadar 92500 Rueil Malmaison	Tel.: +33 (0)1 41 29 82 00 Fax: +33 (0)1 47 51 80 20	www.schneider-electric.fr
French Polynesia	Contacts are assured by	Schneider Electric Australia		
French West Indies	Contacts are assured by	Schneider Electric Dominican Rep.		
Gabon	Contacts are assured by	Schneider Electric Cameroon		
Gambia	Contacts are assured by	Schneider Electric Senegal		
Georgia	Contacts are assured by	Schneider Electric Russian Fed.		
Germany	■ Schneider Electric GmbH	Gothaer Straße 29 D-40880 Ratingen	Tel.: +49210 240 40 Fax: +492 10 240 49 256	www.schnelderelectric.de
Ghana	■ Schneider Electric Ghana	PMB Kia 3rd Floor Opelbea House Airport Commercial Center Liberation road - Accra	Tel. : +233 21 70 11 687 Fax : +233 21 77 96 22	
Gibraltar	Contacts are assured by	Schneider Electric Spain		
Greece	■ Schneider Electric AE	14th km - RN Athens-Lamia GR - 14564 Kifissia	Tel.: +302 106 29 52 00 Fax: +302 106 29 52 10	www.schneider-electric.com.gr
Greenland	Contacts are assured by	Schneider Electric United States		
Grenada	Contacts are assured by	Schneider Electric Dominican Rep.		
Guadeloupe	Contacts are assured by	Schneider Electric Martinique		
Guam	Contacts are assured by	Schneider Electric Australia		



Schneider Electric worldwide

Up-dated: 28-07-2003

Guatemala	Contacts are assured by	Schneider Electric United States		
Gulnea-Bissau	Contacts are assured by	Schneider Electric Sénégal		
Gulnea	Contacts are assured by	Schneider Electric Ivory Coast		
Guyana	Contacts are assured by	Schneider Electric United States		
Haiti	Contacts are assured by	Schneider Electric Dominican Rep.		
Heard & Mac Donald Isl.	Contacts are assured by	Schneider Electric Australia		
Honduras	Contacts are assured by	Schneider Electric United States		
Hong Kong	■ Schneider Electric (Hong Kong) Ltd	Room 3108-28, 31th Floor, Sun Hung Kal Centre, 30 Harbour Road, Wanchai	Tel.: +852 25 65 06 21 Fax: +852 28 11 10 29	
Hungary	■ Schneider Electric Hungária Villamosági Rt.	Fehérvári út 108 – 112 H-1116 Budapest	Tel.: +36 1 382 26-06 Fax: +36 1 206 1429	www.schneider-electric.hu
Iceland	Contacts are assured by	Schneider Electric Denmark		
India	■ Schneider Electric India	Max House, 1 Dr Jha Marg, Okhla 110 020 New Delhi	Tel. : +91 11 631 85 84 Tel. : +91 11 631 71 61	www.schneliderelectric-in.com
Indonesia	■ P.T. Schneider Indonesia	Ventura Building 7th Floor Jalan R.A. Kartini Kav.26 Cilandak - 12430 Jakarta	Tel.: +62 +21 750 44 06 Fax: +62 +21 750 44 15/ 16	www.schneider-electric.co.id
Iran (Islamic Republic of)	■ Telemecanique Iran	1047 Avenue VALI ASSR P.O. Box 15875-3547 15116 Teheran	Tel.: +98 218 71 01 42 Fax: +98 218 71 81 87	
Irak	■ Schneider Electric Industries SA	38050 Grenoble Cedex 9	Tel.: +33 04 76 60 54 27 Fax: +33 04 76 60 56 60	
Ireland	■ Schneider Electric Ireland	Maynooth Road Cellbridge - Co. Kildare	Tel.: +353+0 1 6012200 Fax: +353+0 1 6012201	www.schneliderelectric.ie
Italy	■ Schneider Electric S.p.A.	Centro Direzionale Colleoni Palazzo Sirio - Viale Colleoni, 7 20041 Agrate Brianza (MI)	Tel.: +39 39 655 8111 Fax: +39 39 605 6237	www.schneliderelectric.it
Ivory Coast	■ Schneider Electric Afrique de l'Ouest	Rue Pierre et Marie Curie 18 BP 2027 Abidjan 18	Tel.: +225 21 75 00 10 Fax: +225 21 75 00 30	
Jamaica	■ Schneider Electric	Shop#5, Plaza Dunrobin 30 Dunrobin Avenue - Kingstown	Tel. : +1876 755 41 27 Tel. : +831 87 74	
Japan	■ Schneider Electric Japan Ltd	Torigoe F. Bldg 1-8-2, Torigoe Taiko-Ku - 111-0054 Tokyo	Tel.: +81 358 35 35 81 Fax: +81 358 35 35 85	www.schneider-electric.co.jp
Jordan	■ Schneider Electric Industr. Jordan	Jordan University Street Abu Al Haj Commercial Complex 2nd Floor - Office # 202 - Amman	Tel.: 962 65 16 78 87 Fax: 962 65 16 79 1	
Kazakhstan	■ Schneider Electric Kazakhstan Liaison Office	Prospekt Abaia 157 off 9 480009 Almaty	Tel. : +7 327 250 93 88 Tel. : +7 327 250 63 70	
Kenya	■ Schneider East Africa	Power Technics Complex Monbasa Road - PO Box 46345 Nairobi	Tel. : +254 2.824.156 Fax : +254 2.824.157	
Kiribati	Contacts are assured by	Schneider Electric Australia		
Korea	■ Schneider Electric Korea Ltd	3Floor, Cheil Bldg., 94-46, 7-Ka Youngdeungpodong, Youngdeungpo-ku 150-037 Seoul	Tel. : +82 2 2630 9700 Fax : +82 2 2630 9800	www.csinfo.co.kr/schneider/
Kurdistan	Contacts are assured by	Schneider Electric Russian Fed.		
Kuwait	■ Schneider Electric Kuwait	Al Gaas Tower - Sharq 2nd Floor PO Box 20092 - 13 061 Safat	Tel.: +965 240 75 46 Fax: +965 240 75 06	
Kyrgyz Republic	Contacts are assured by	Schneider Electric Russian Fed.		
Laos	Contacts are assured by	Schneider Electric Thailand		
Latvia	■ Lexel Electric	60A A.Deglava str. LV1035 Riga	Tel. : +371 780 23 74/75 Fax : +371 754 62 80	
Lebanon	■ Schneider Electric Liban	Tabaris, Avenue Charles Malek Immeuble Ashada, 8 P.O. Box 166223 - Beyrouth	Tel. : +961 1 20 46 20 Tel. : +961 1 20 31 19	
Lesotho	Contacts are assured by	Schneider Electric South Africa		
Liberia	Contacts are assured by	Schneider Electric Ghana		
Libya	Contacts are assured by	Schneider Electric Tunisia		
Liechtenstein	Contacts are assured by	Schneider Electric Switzerland		
Lithuania	■ Lexel Electric	44, Verkui str. LT-2012 Vilnius	Tel. : +370 278 59 59/61 Fax : +370 278 59 60	
Loro Sae	Contacts are assured by	Schneider Electric Australia		
Luxembourg	■ Schneider Electric Industrie SAS	Agence de Metz 1, Rue Graham Bell - BP n° 35190 57075 Metz cedex 3 - France	Tel.: 33 03 87 39 06 03 Fax: 33 03 87 74 25 96	www.schneider-electric.fr



Schneider Electric worldwide

Up-dated: 28-07-2003

Macau	Contacts are assured by	Schneider Electric China		
Macedonia	Contacts are assured by	Schneider Electric Bulgaria		
Madagascar	Contacts are assured by	Schneider Electric la Reunion		
Malawi	Contacts are assured by	Schneider Electric South Africa		
Malaysia	■ Schneider Electric (Malaysia) Sdn Bhd	No.11 Jalan U1/19, Seksyen U1 Hicom-Glenmarle Industrial Park 40150 Shah Alam Selangor Darul Ehsan	Tel.: (603) 7883 6333 Fax: (603) 7883 6188	www.schneider-electric.com.my
Maldives	Contacts are assured by	Schneider Electric Reunion		
Mali	Contacts are assured by	Schneider Electric Senegal		
Malta	Contacts are assured by	Schneider Electric Tunisia		
Marshall Islands	Contacts are assured by	Schneider Electric Australia		
Martinique	■ Schneider Electric	Schneider Electric Immeuble Cottrell - ZI de la Lézarde 97232 Le Lamentin	Tel.: +05 96 51 06 00 Fax: +05 96 51 11 26	
Mauritania	Contacts are assured by	Schneider Electric Senegal		
Mauritius	■ Schneider Electric	Route côtière Calodyne - Mauritius	Tel.: 230 282 18 83 Fax: 230 282 18 84	
Mayotte	Contacts are assured by	Schneider Electric Reunion		
Mexico	■ Groupe Schneider Mexico	Calz. Rojo Gomez N° 1121-A Col. Guadalupe del Moral México, D.F. - C.P. 09300	Tel.: +525 686 30 00 Fax: +525 686 24 09	www.schneider-electric.com.mx
Micronesia	Contacts are assured by	Schneider Electric Australia		
Moldova	Contacts are assured by	Schneider Electric Romania		
Monaco	Contacts are assured by	Schneider Electric France		
Mongolia	Contacts are assured by	Schneider Electric Russian Fed.		
Montserrat	Contacts are assured by	Schneider Electric Dominican Rep.		
Morocco	■ Schneider Electric Morocco	26, rue Ibnou Khalikane Quartier Palmiers 20100 Casablanca	Tel.: +212 299 08 48 to 57 Fax: +212 299 08 67 and 69	www.schneider.co.ma
Mozambique	Contacts are assured by	Schneider Electric South Africa		
Myanmar	Contacts are assured by	Schneider Electric Singapore		
Namibia	Contacts are assured by	Schneider Electric South Africa		
Nauru	Contacts are assured by	Schneider Electric Australia		
Nepal	Contacts are assured by	Schneider Electric India		
Netherlands	■ Schneider Electric BV	Waardevweg 40 - Postbus 836 2003 RV Haarlem	Tel.: +31 23 512 4124 Fax: +31 23 512 4100	www.schneider-electric.nl
Netherlands Antilles	Contacts are assured by	Schneider Electric Dominican Rep.		
New Caledonia	Contacts are assured by	Schneider Electric Australia		
New Zealand	■ Schneider Electric (NZ) Ltd	14 Charann Place Avondale P.O. Box 15355 - New Lynn Auckland	Tel.: +64 9 829 04 90 Fax: +64 9 829 04 91	www.schneider-electric.co.nz
Nicaragua	Contacts are assured by	Schneider Electric United States		
Niger	Contacts are assured by	Schneider Electric Ivory Coast		
Nigeria	■ Schneider Electric Nigeria Limited	Biro plaza - 8th Floor - Plot 634 Abeyemo Alakija Street Victoria Islan - Lagos	Tel.: +234 1 2702973 Fax: +234 1 2702976	
Niue	Contacts are assured by	Schneider Electric Australia		
Norfolk Island	Contacts are assured by	Schneider Electric Australia		
North Korea	Contacts are assured by	Schneider Electric China		
Northern Mariana Islands	Contacts are assured by	Schneider Electric Australia		
Norway	■ Schneider Electric Norge A/S	Solgaard Skog 2 Postboks 128 - 1501 Moss	Tel.: +47 6924 9700 Fax: +47 6925 7871	www.schneider-electric.no
Oman	■ Schneider Electric CA	c/o Arab Development Co PO Box 439 - 113 Muscat	Tel.: +968 77 163 64 Fax: +968 77 104 49	
Pakistan	■ Schneider Electric Pakistan	43-L, 2nd floor, M.M. Alam Road, Gulberg II - Lahore	Tel.: +92 42 5754471 à 73 Fax: +92 42 5754474	
Palau	Contacts are assured by	Schneider Electric Australia		
Panama	Contacts are assured by	Schneider Electric United States		
Papua New Guinea	Contacts are assured by	Schneider Electric Australia		
Paraguay	Contacts are assured by	Schneider Electric Uruguay		



Schneider Electric worldwide

Up-dated: 28-07-2003

Peru	■ Schneider Electric Peru S.A.	Los Telares n°231 Urb. Vulcano, Ate Lima 03	Tel.: +511 348 44 11 Fax: +511 348 05 23	www.schneider-electric.com.pe
Philippines	■ Schneider Electric Philippines, Inc	5th Floor, ALCO Building 391 Sen, Gli Puyat Avenue Makati 1209	Tel. : +632 896 6063 Fax : +632 896 7229	
Pitcairn	Contacts are assured by	Schneider Electric Australia		
Poland	■ Schneider Electric Polska Sp.zo.o.	ul. Lubinowa 4a 03-878 - Warszawa	Tel.: +48 22 511 8 200 Fax: +48 22 511 8 210	www.schneider-electric.pl
Portugal	■ Schneider Electric Portugal	Av.do Forte, 3 Edifício Suécia II, Piso 3-A CP 2028 Camaxide 2795 Linda-A-Velha	Tel.: +351 21 416 5800 Fax: +351 21 416 5857	www.schneiderelectric.pt
Puerto Rico	Contacts are assured by	Schneider Electric United States		
Qatar	■ Schneider Electric Qatar Branch	c/o Khalifa BinFahred Al Thanl Trad.and Co - P.O. Box 4484 Doha	Tel.: +97 4424358 Fax: +97 4424358	
Reunion	■ Schneider Electric	Immeuble Futura, 190, rue des 2 canons BP 646 - 97497 Sainte Clothilde	Tel.: +262 28 14 28 Fax: +262 28 39 37	
Romania	■ Schneider Electric	Bd Ficusului n°42 Apimondia, Corp.A, et.1, Sector 1 Bucuresti	Tel.: +401 203 06 50 Fax: +401 232 15 98	www.schneider-electric.ro
Russian Federation	■ Schneider Electric ZAO	Erisseyskaya 37 129 281 Moscow	Tel.: +7095 797 40 00 Fax: +7095 797 40 03	www.schneider-electric.ru
Rwanda	Contacts are assured by	Schneider Electric Kenya		
Samoa	Contacts are assured by	Schneider Electric Australia		
San Marino	Contacts are assured by	Schneider Electric Italy		
Sandwich & Georgia Island	Contacts are assured by	Schneider Electric Australia		
Sao Tome & Principe	Contacts are assured by	Schneider Electric Senegal		
Saudi Arabia	■ Schneider Electric	Second Industrial City P.O. Box 89249 - 11682 Rlyadh	Tel.: +966 1 265 1515 Fax: +966 1 265 1860	
Senegal	■ Schneider Electric Sénégal	BP 15952 - Dakar-Fann Rond point N'Gor - Dakar	Tel.: +221 820 68 05 Fax: +221 820 58 50	
Seychelles	Contacts are assured by	Schneider Electric Reunion		
Sierra Leone	Contacts are assured by	Schneider Electric Ghana		
Singapore	■ Schneider Electric Singapore Pte Ltd	10 Ang Mo Kio Street 65 #02-17/20 TechPoint Singapore 569059	Tel.: +65 484 78 77 Fax: +65 484 78 00	www.schneider-electric.com.sg
Slovak Republic	■ Schneider Electric Slovakia spol s.r.o.	Borskova 10 SK-821 06 Bratislava	Tel. : +02 45 52 40 10 and 40 30 Fax : +02 45 52 40 00	www.schneider-electric.sk
Slovenia	■ Schneider Electric, d.o.o.	Dunasjka 47 1000 Ljubljana	Tel. : +386 1 23 63 555 Fax : +386 1 23 63 559	www.schneider-electric.si
Solomon Islands	Contacts are assured by	Schneider Electric Australia		
Somalia	Contacts are assured by	Schneider Electric Egypt		
South Africa	■ Schneider Electric South Africa (PTY) Ltd	Private Bag X139 Halfway House 1685 - Midrand.	Tel.: +27 11 254 6400 Fax: +27 11 315 8830	www.schneider-electric.co.za
Spain	■ Schneider Electric España, S.A.	Pl. Dr. Letamendi, 5-7 08007 Barcelona	Tel.: +34 93 484 3100 Fax: +34 93 484 3308	www.schneiderelectric.es
Sri Lanka	■ Schneider Electric Industries SA	Liaison office SRI Lanka Level 3B Vaillant towers 48/7 Nawam Mawatha-Colombo 2	Tel. : +94 77 48 54 89	www.schneiderelectric-ln.com
St Helena	Contacts are assured by	Schneider Electric Italy		
St Kitts & Nevis	Contacts are assured by	Schneider Electric Dominican Rep.		
St Lucia	Contacts are assured by	Schneider Electric Dominican Rep.		
St Pierre et Miquelon	Contacts are assured by	Schneider Electric Dominican Rep.		
St Vincent & Grenadines	Contacts are assured by	Schneider Electric Dominican Rep.		
Sudan	Contacts are assured by	Schneider Electric Egypt		
Suriname	Contacts are assured by	Schneider Electric United States		
Svalbard & Jan Mayen Isl.	Contacts are assured by	Schneider Electric Denmark		
Swaziland	Contacts are assured by	Schneider Electric South Africa		
Sweden	■ Schneider Electric AB	Djupdalsvägen 17/19 19129 Sollentuna	Tel.: +46 8 623 84 00 Fax: +46 8 623 84 85	www.schneider-electric.se
Switzerland	■ Schneider Electric (Switzerland) S.A.	Schermerwaldstrasse 11 CH - 3063 Ittigen	Tel.: +41 31 917 3333 Fax: +41 31 917 3355	www.schneider-electric.ch



Schneider Electric worldwide

Up-dated: 28-07-2003

Syrian Arab Republic	■ Schneider Electric Syria	Elba Street - Malkd Ghelbeh and Qassas bldg, 1st floor PO Box 33876-Damascus	Tel. : +963 11 37 49 88 00 Fax : +963 11 37 17 55 9	
Taiwan, Republic of China	■ Schneider Electric Taiwan Co Ltd	2Fl., N°37, Ji-Hu Road, Nei-Hu Dist., Taipei 114	Tel. : +886 2 8751 6388 Fax : +886 2 8751 6389	www.schneider-electric.com.tw
Tajikistan	Contacts are assured by	Schneider Electric Russian Fed.		
Tanzania, United Rep. of	Contacts are assured by	Schneider Electric Kenya		
Thailand	■ Schneider (Thailand) Ltd	20th Floor Richmond Building 75 Sukhumvit 26 Road, Klongtoey Bangkok 10110	Tel.: +662 204 9888 Fax: +662 204 9816	www.schneider-electric.co.th
Togo	Contacts are assured by	Schneider Electric Ivory Coast		
Tokelau	Contacts are assured by	Schneider Electric Australia		
Tonga	Contacts are assured by	Schneider Electric Australia		
Trinidad & Tobago	■ Schneider Electric	6, 1st Street West Ext. Beaulieu Avenue Trincity Trinidad West Indies	Tel.: 1868 640 42 04 Fax: 1868 640 42 04	
Tunisia	■ Schneider Electric Tunisia	Rue du Lac Oubelra 1053 Les Berges du Lac - Tunis	Tel.: +216 71 960 477 Fax: +216 71 960 342	
Turkey	■ Schneider Elektrik Sanayi Ve Ticaret A.S.	Tütüncü Mehmet Efendi Cad. N°:110 Kat 1-2 - 81080 Göztepe - Istanbul	Tel.: +90 21 63 86 95 70 Fax: +90 21 63 86 38 75	www.schnelderelectric.com.tr
Turkmenistan	■ Schneider Electric Turkmenistan Liaison Office	rue Neitralny Turkmenistan 28, off.326/327 74 000 Achgabad	Tel. : +993 12 46 29 52 Fax : +993 12 46 29 52	
Turks & Calcos Islands	Contacts are assured by	Schneider Electric Dominican Rep.		
Tuvalu	Contacts are assured by	Schneider Electric Australia		
Uganda	Contacts are assured by	Schneider Electric Kenya		
Ukraine	■ Schneider Electric	Rue Krechtchalik 2 252601 Kiev	Tel.: +380 44 462 04 25 Fax: +380 44 462 04 24	www.schneider-electric.com.ua
United Arab Emirates	■ Schneider Electric Abu Dhabi	PO Box 29580 Office Floor 2/Lulu Street Al Marina Plaza Tower Abu Dhabi	Tel.: +9712 6 339444 Fax: +9712 6 316606	
United Kingdom	■ Schneider Electric Ltd	Braywick House East Windsor Road - Maldenhead Berkshire SL6 1 DN	Tel.: +44 (0)1 628 508 500 Fax: +44 (0)1 628 508 508	www.schneider.co.uk
United States	■ Schneider Electric	North American Division 1415 Roselle Road Palatine - IL 60067	Tel.: +1 847 397 2600 Fax: +1 847 925 7500	www.squared.com
Uruguay	■ Schneider Electric Uruguay S.A.	Ramon Masini 3190 Montevideo	Tel. : +59 82 707 2392 Fax : +59 82 707 2184	
Uzbekistan	Contacts are assured by	Schneider Electric Russian Fed.		
Vanuatu	Contacts are assured by	Schneider Electric Australia		
Vatican city St./Holy See	Contacts are assured by	Schneider Electric Italy		
Venezuela	■ Schneider Mg SD TE, S.A	Calle 162/ Piso 2 Edificio Centro Cynamid La Urbina, 1070 - 75319 Caracas	Tel.: +58 2 241 13 44 Fax: +58 2 243 60 09	www.schneider-electric.com.ve
Viet Nam	■ R.R.O. of Schneider Electric Industries S.A.S. In Viet Nam	Unit 2.9, 2nd Floor, e-Town Building 364 Cong Hoa Street Tan Binh District - Ho Chi Minh City	Tel.: +84 8 8103 103 Fax: +84 8 8120 477	
Virgin Islands	Contacts are assured by	Schneider Electric Dominican Rep.		
Wallis & Futuna Islands	Contacts are assured by	Schneider Electric Australia		
Western Sahara	Contacts are assured by	Schneider Electric Morocco		
Yemen	Contacts are assured by	Schneider Electric U.A.E.		
Yugoslavia	■ Schneider Electric Jugoslavija d.o.o.	Ratarski put 27d 11186 Belgrade	Tel.: +381 11 192 414 Fax: +381 11 107 125	
Zambia	■ Schneider Zambia	Zambia Office c/o Matipi Craft Center Building Plot 1036 - Accra Road PO Box 22792 - Kitwe	Tel.: +260 222 22 52 Fax: +260 222 83 89	
Zimbabwe	■ Schneider Electric	Zimbabwe Liaison Office 75A Second Street (corner Livingstone Avenue) Harare	Tel.: +263 4 707 179/180 Fax: +263 4 707 176	

Schneider Electric Industries SAS

Headquarters

89, bd Franklin Roosevelt
F - 92508 Rueil Malmaison Cedex

<http://www.schneider-electric.com>

ART. 070283

Owing to changes in standards and equipment, the characteristics given in the text and images in this document are not binding us until they have been confirmed with us.

Production : Schneider Electric Industries
Photos : Schneider Electric Industries
Printed by :

November 2003



MKT/ED03113EN