

Inductive proximity sensors OsiSense XS

Cubic range

Catalogue





MV-BL
250

250

72

A sensor that quickly and easily adapts to your machines

With unique one-click mounting and a rotating detection head, the new **OsiSense™ XS cubic sensor** can be installed quickly and easily on any machine or equipment.

Maintenance is simplified thanks to quick mounting / removal and LED sensor status indicators that are clearly visible from a long distance and from any direction.

> Simple installation, easier maintenance

One-click concept makes operation and servicing easier

> Robustness and compliance with SIL2

The first general purpose proximity sensor with SIL2 certification (Safety Integrity Level 2)

> Selection guide

Easily select the product best suited to your application

Contents

Customer benefits	pages 2 and 3
OsiSense XSC sensor - Digital, 40 x 40 x 70 mm	pages 4 and 5
OsiSense XSC sensor - Digital, 40 x 40 x 117 mm	pages 6 and 7
OsiSense XSC sensor - Analogue, 40 x 40 x 70/117 mm	pages 8 and 9
OsiSense XSC sensor - Factor 1, weld field immune, 40 x 40 x 70/117 mm...	pages 10 and 11
Product reference index.....	page 12

Simply easy!™ 

> Simple installation, easier maintenance

The new OsiSense XS proximity sensors, available in cubic and rectangular versions, have a 5-position turret head, enabling accurate detection in any direction. The orientation of the head can be adjusted manually and quickly without any special tools.

5-position
Turret head

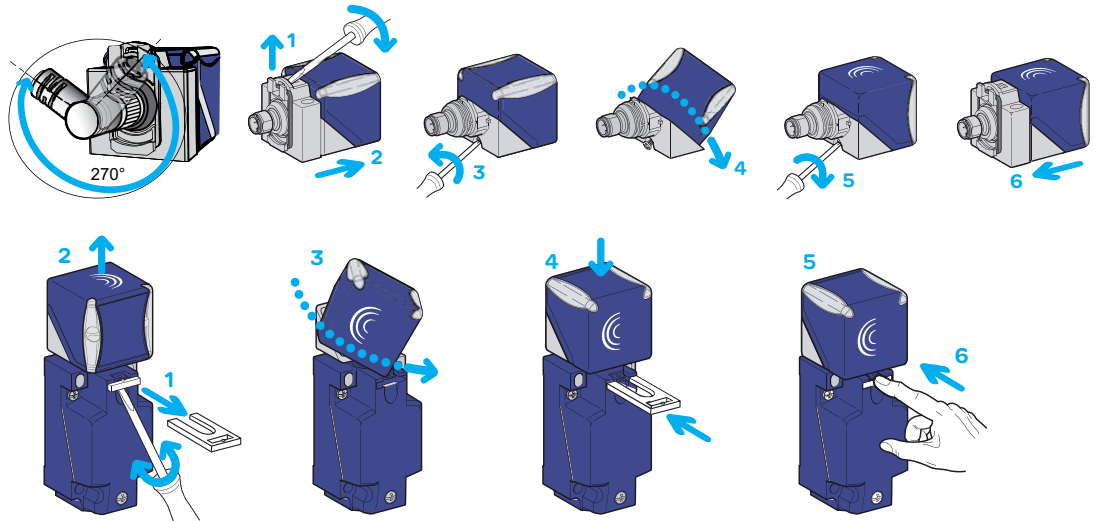

Maintenance
time **halved**

LEDs visible from any direction provide fast status evaluation from metres away.

For the cubic version, the detection head can be changed without removing the whole product from the machine, thanks to the innovative **one-click concept**.



> Reliable and robust detection

The compact design and robustness of the new sensors make them perfectly suited for use in those industrial applications where there is a high risk of damage or collision with moving parts.

The OsiSense XS range includes the first SIL2 certified cubic inductive sensor that significantly reduces the risk of failure, minimizing the chance of damage to your conveyors and machines.

Analog versions are also available for detection and monitoring of material handling processes and many packaging applications.

The OsiSense XS sensors are IP69K tested and validated for use in rough industrial environments.

Factor 1 versions are mainly dedicated to different metal detection. These specific products provide a very high immunity to magnetic fields. This offer is also really suitable for any high sensing distance on stainless steel or aluminium metallic detection due to the correction factor.



SIL2
Certification

Selection guide



XS-C2			Flush mountable		Non flush mountable	
Sensing distance Sn			15 mm	20 mm	25 mm	40 mm
NO+NC	DC4	PNP	-	XS8C2A1PC M12	-	XS8C2A4PC M12
		NPN	-	XS8C2A1NC M12	-	XS8C2A4NC M12
Factor 1 NO+NC	DC4	PNP	-	XS9C2A1PC M12	-	-
		NPN	-	XS9C2A1NC M12	-	-
NO or NC	DC3	PNP	XS7C2A1P A M12	-	-	-
		NPN	XS7C2A1N A M12	-	-	-
	DC2	PNP	XS7C2A1D A M12	XS8C2A1D A M12	-	XS8C2A4D A M12
		NPN	XS7C2A1M A U20	XS8C2A1M A U20	-	XS8C2A4M A U20
Select the output function	NO	A	A	-	A	
	NC	B	B	-	B	
Analogue	0...10 V		-	-	XS9C2A2A1 M12	-
	4...20mA		-	-	XS9C2A2A2 M12	-



XS-C4			Flush mountable		Non flush mountable	
Sensing distance Sn			15 mm	20 mm	25 mm	40 mm
NO+NC	DC4	PNP	-	XS8C4A1PC P20	-	XS8C4A4PC P20
		NPN	-	XS8C4A1NC P20	-	XS8C4A4NC P20
Factor 1 NO+NC	DC4	PNP	-	XS9C4A1PC P20	-	-
		NPN	-	XS9C4A1NC P20	-	-
NO or NC	DC2	PNP	XS7C4A1DP P20	XS8C4A1DP P20	-	XS8C4A4DP P20
		NPN	XS7C4A1MP P20	XS8C4A1MP P20	-	XS8C4A4MP P20
Analogue	0...10 V		-	-	XS9C4A2A1 P20	-
	4...20mA		-	-	XS9C4A2A2 P20	-
Select the type of connection	M20		P20	P20	P20	P20
	PG13		G13	G13	G13	G13
	1/2" NPT		N12	N12	N12	N12

SIL2 sensors

A comprehensive range of cubic and flat inductive sensors
Refer to the Telemecanique Sensors panorama



Dimensions	8 X 22 X 8 mm	15 X 32 X 8 mm	26 X 26 X 8 mm	40 X 40 X 15 mm	80 X 80 X 26 mm
Sensing distance Sn	2,5 mm	5 mm	10 mm	15 mm	40 mm
References	XS7J1...	XS7F1...	XS7E1...	XS7C1...	XS7D1...

Inductive proximity sensors

OsiSense XS, general purpose
Cubic case, 40 x 40 x 70 mm, M12 or 1/2"-20UNF
connector
5 position turret head

Sensor	Flush mountable in metal	Non flush mountable in metal
--------	--------------------------	------------------------------

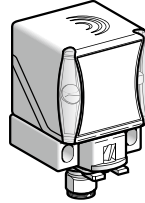

Nominal sensing distance (Sn)	15 mm	20 mm	40 mm
-------------------------------	-------	-------	-------

References

4-wire ---	PNP NO+NC	–	XS8C2A1PCM12	XS8C2A4PCM12
	NPN NO+NC	–	XS8C2A1NCM12	XS8C2A4NCM12
3-wire ---	PNP NO	XS7C2A1PAM12	–	–
	NPN NO	XS7C2A1NAM12	–	–
	PNP NC	XS7C2A1PBM12	–	–
	NPN NC	XS7C2A1NBM12	–	–
2-wire ---	NO	XS7C2A1DAM12	XS8C2A1DAM12	XS8C2A4DAM12
	NC	XS7C2A1DBM12	XS8C2A1DBM12	XS8C2A4DBM12
2-wire (~/---) unprotected (1)	NO	XS7C2A1MAU20	XS8C2A1MAU20	XS8C2A4MAU20
	NC	XS7C2A1MBU20	XS8C2A1MBU20	XS8C2A4MBU20
Weight (kg)	0.149	0.149	0.149	

Characteristics

Operating zone		0...12 mm	0...16 mm	0...32 mm
Product certifications		UL, CSA, CE, TÜV (4-wire versions)		
Conformity to standards		IEC 60947-5-2		
Conformity to safety standards (2)	For XS8C2A●PCM12	EN 62061 (2005): SILcl2 EN 61508 (2010): SIL 2, EN ISO 13849 (2008): PL d		
Reliability data (2)	For XS8C2A●PCM12	MTTFd = 1546 years PFHd = 7.4 10 ⁻⁸ 1/h		
Connection		M12 connector for --- versions 1/2"-20UNF connector for ~/--- versions		
Differential travel		3...15% of Sr		
Degree of protection	Conforming to IEC 60529 and DIN 40050	IP 65, IP 67 and IP 69K		
Temperature	Storage Operation (3)	- 40...+ 85°C - 25...+ 70°C		
Material		Case: PBT		
Vibration resistance	Conforming to IEC 60068-2-6	25 gn, amplitude ± 2 mm (f = 10...55 Hz)		
Shock resistance	Conforming to IEC 60068-2-27	50 gn for 11 ms		
Indicators	Output state Power on	Yellow LED Green LED, for 4-wire ---, 3-wire --- and 2-wire ~/--- versions		
Rated supply voltage	4-wire ---	12...48 V with protection against reverse polarity		
	3-wire ---	12...24 V with protection against reverse polarity		
	2-wire ---	12...48 V with protection against reverse polarity		
	2-wire ~/---	24...240 V (~ 50/60 Hz)		
Voltage limits (including ripple)	4-wire ---	10...58 V		
	3-wire ---	10...36 V		
	2-wire ---	10...58 V		
	2-wire ~/---	20...264 V		
Current consumption, no-load	3-wire and 4-wire ---	< 15 mA		
Residual current, open state	2-wire ---	< 0.6 mA		
	2-wire ~/---	1.5 mA		
Switching capacity	3-wire and 4-wire ---	< 200 mA with overload and short-circuit protection		
	2-wire ---	< 100 mA with overload and short-circuit protection		
	2-wire ~/---	~: 5...300 mA (1) ---: 5...200 mA (1)		
Voltage drop, closed state	3-wire and 4-wire ---	< 2 V		
	2-wire ---	< 4.2 V		
	2-wire ---/~	< 5.5 V		
Maximum switching frequency		Flush mountable: --- 300 Hz, ~ 25 Hz Non flush mountable: --- 150 Hz, ~ 25 Hz		
Delays	First-up	7 ms (3-wire and 4-wire ---), 20 ms (2-wire --- and 2-wire ---/~)		
	Response	Flush mountable: ≤ 1.2 ms. Non flush mountable: ≤ 1.4 ms		
	Recovery	Flush mountable: ≤ 1.8 ms. Non flush mountable: ≤ 3.5 ms		

(1) Sensor must be protected by a 0.4 A quick-blow fuse (reference **XUZE04**) connected in series with the load.

(2) SIL 2 protection can only be obtained by connecting both outputs to a safety PLC. Please refer to the "Safety solutions using Preventa" catalogue.

(3) Sensors are available for very low temperatures (suffix **TF**: - 40°C, + 70°C) or very high temperatures (suffix **TT**: - 25°C, + 85°C). Please consult our Customer Care Centre.

Inductive proximity sensors

OsiSense XS, general purpose
Cubic case, 40 x 40 x 70 mm, M12 or 1/2"-20UNF
connector
5 position turret head

Setting-up precautions

Minimum mounting distances (mm)

		Side by side	Face to face	Facing a metal object
Sensors flush mountable in metal	XS7C2A1●●	$e \geq 60$	$e \geq 120$	$e \geq 45$
	XS8C2A1●●	$e \geq 80$	$e \geq 160$	$e \geq 60$
Sensors non flush mountable in metal	XS8C2A4●●	$e \geq 160$	$e \geq 320$	$e \geq 120$

Wiring schemes

4-wire ---, NO + NC outputs

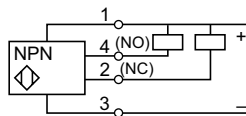
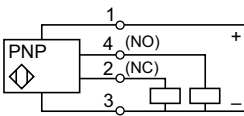

3-wire, PNP

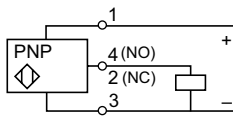

3-wire, NPN

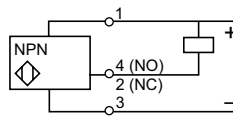

2-wire, 1/2"-20UNF

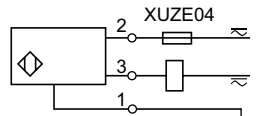

2-wire ---, NO output (M12 connector)

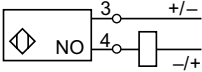

2-wire ---, NC output (M12 connector)

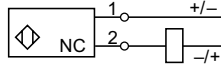

M12 connector

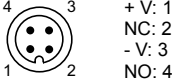

1/2"-20UNF connector

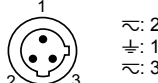

Accessory references

Description	Type	Length m	Reference	Weight kg
Pre-wired M12 connectors Female, 4-pin, zinc die-cast, nickel plated clamping ring	Straight	2	XZCP1141L2	0.090
		5	XZCP1141L5	0.190
		10	XZCP1141L10	0.370
	Elbowed	2	XZCP1241L2	0.090
		5	XZCP1241L5	0.190
		10	XZCP1241L10	0.370
Pre-wired 1/2"-20UNF connectors Female, 3-pin, zinc die-cast, nickel plated clamping ring	Straight	5	XZCP1865L5	0.180
		10	XZCP1865L10	0.350
		10	XZCP1965L10	0.350
	Elbowed	5	XZCP1965L5	0.180
		10	XZCP1965L10	0.350

Dimensions

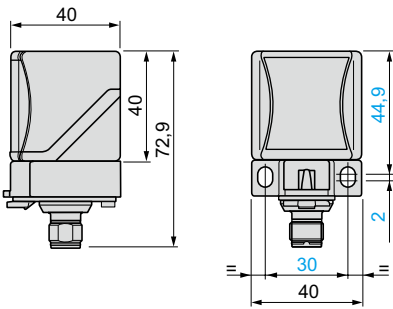

Head positions

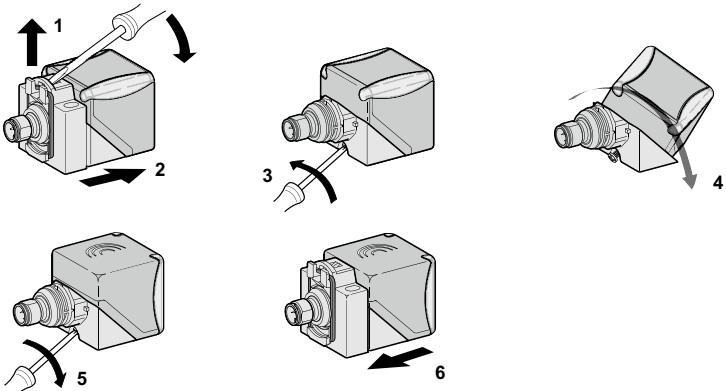

Example SIL 2 wiring scheme (with Preventa XPSMF40 safety PLC)

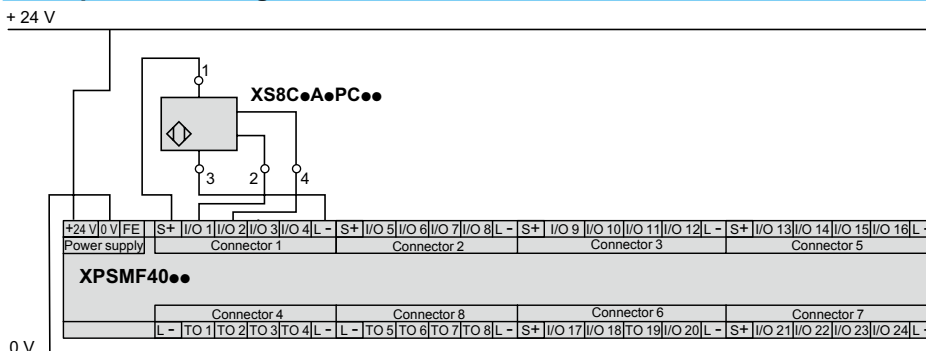

SFF (Safe Failure Fraction): 92,68 %
DC (Diagnosis Coverage): 75,8 %

S+: 24 V
L -: 0 V
I/O 1...24: safety I/O

Inductive proximity sensors

OsiSense XS, general purpose

Plastic case, 40 x 40 x 117 mm, plug-in

5 position turret head

Sensor	Flush mountable in metal	Non flush mountable in metal
--------	--------------------------	------------------------------

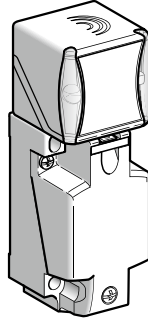

Nominal sensing distance (Sn)	15 mm	20 mm	40 mm
-------------------------------	-------	-------	-------

References

4-wire ---	PNP NO+NC	–	XS8C4A1PCP20	XS8C4A4PCP20
	NPN NO+NC	–	XS8C4A1NCP20	XS8C4A4NCP20
2-wire ---	NO or NC programmable	XS7C4A1DPP20	XS8C4A1DPP20	XS8C4A4DPP20
2-wire ($\sim\text{---}$) unprotected (1)	NO or NC programmable	XS7C4A1MPP20	XS8C4A1MPP20	XS8C4A4MPP20
Weight (kg)		0.244	0.244	0.244

*Note: These sensors have an M20 cable entry. They can also be supplied with a PG 13.5 cable entry (e.g. **XS8C4A4PCG13**) or a 1/2" NPT cable entry (e.g. **XS8C4A1MPN12**). Please consult our Customer Care Centre.*

Characteristics

		0...12 mm	0...16 mm	0...32 mm
Operating zone		0...12 mm	0...16 mm	0...32 mm
Product certifications		UL, CSA, CE. TÜV (4-wire versions)		
Conformity to standards		IEC 60947-5-2		
Conformity to safety standards (2)		For XS8C4A●PCP20 EN 62061 (2005): SILcl2, EN 61508 (2010): SIL 2, EN ISO 13849 (2008): PL d		
Reliability data (2)		For XS8C4A●PCP20 MTTFd = 1546 years PFHd = 7.4 10 ⁻⁸ 1/h		
Connection		Screw terminals, clamping capacity: 2 or 4 x 1.5 mm ² / 2 or 4 x 16 AWG (3)		
Differential travel		3...15% of Sr		
Degree of protection		Conforming to IEC 60529 and DIN 40050 IP 65, IP 67 and IP 69K		
Temperature		Storage -40...+85°C Operation (4) -25...+70°C		
Material		Case: PBT		
Vibration resistance		Conforming to IEC 60068-2-6 25 gn, amplitude ± 2 mm (f = 10...55 Hz)		
Shock resistance		Conforming to IEC 60068-2-27 50 gn for 11 ms		
Indicators		Output state Yellow LED Power on Green LED, for 4-wire --- and 2-wire $\sim\text{---}$ versions		
Rated supply voltage		4-wire --- 12...48 V with protection against reverse polarity 2-wire --- 12...48 V with protection against reverse polarity 2-wire $\sim\text{---}$ 24...240 V (\sim 50/60 Hz)		
Voltage limits (including ripple)		4-wire --- 10...58 V 2-wire --- 10...58 V 2-wire $\sim\text{---}$ 20...264 V		
Current consumption, no-load		4-wire --- < 15 mA		
Residual current, open state		2-wire --- < 0.6 mA 2-wire $\sim\text{---}$ 1.5 mA		
Switching capacity		4-wire --- < 200 mA with overload and short-circuit protection 2-wire --- < 100 mA with overload and short-circuit protection 2-wire $\sim\text{---}$ \sim : 5...300 mA (1) --- : 5...200 mA (1)		
Voltage drop, closed state		4-wire --- < 2 V 2-wire --- < 4.2 V 2-wire $\text{---}/\sim$ < 5.5 V		
Maximum switching frequency		Flush mountable: --- 300 Hz, \sim 25 Hz Non flush mountable: --- 150 Hz, \sim 25 Hz		
Delays		First-up 7 ms (3-wire and 4-wire ---), 20 ms (2-wire --- and 2-wire $\text{---}/\sim$) Response Flush mountable: ≤ 1.2 ms. Non flush mountable: ≤ 1.4 ms Recovery Flush mountable: ≤ 1.8 ms. Non flush mountable: ≤ 3.5 ms		

(1) Sensor must be protected by a 0.4 A quick-blow fuse (reference **XUZE04**) connected in series with the load.

(2) SIL 2 protection can only be obtained by connecting both outputs to a safety PLC. Please refer to the "Safety solutions using Preventa" catalogue.

(3) These sensors are supplied without a cable gland. An adaptable PG 13.5 cable gland is available (reference **XSZPE13**). Accessories are available for connection to an M12 or 7/8"-16UN connector which can be added to the PG 13.5 sensor. Please consult our Customer Care Centre.

(4) Sensors are available for very low temperatures (suffix **TF**: -40°C, +70°C) or very high temperatures (suffix **TT**: -25°C, +85°C). Please consult our Customer Care Centre.

Inductive proximity sensors

OsiSense XS, general purpose
Plastic case, 40 x 40 x 117 mm, plug-in
5 position turret head

Setting-up precautions

Minimum mounting distances (mm)

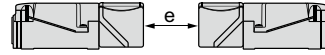
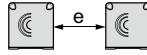

		Side by side	Face to face	Facing a metal object
Sensors flush mountable in metal	XS7C4A1●●	$e \geq 60$	$e \geq 120$	$e \geq 45$
	XS8C4A1●●	$e \geq 80$	$e \geq 160$	$e \geq 60$
Sensors non flush mountable in metal	XS8C4A4●●	$e \geq 160$	$e \geq 320$	$e \geq 120$

Wiring schemes

NO + NC outputs

4-wire ...

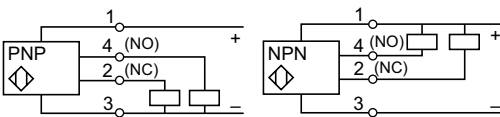

NO or NC outputs, depending on position of link

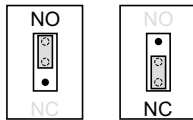

2-wire ... (non polarised)

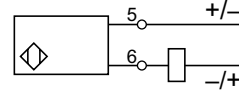

2-wire ~ or ... (programmable)

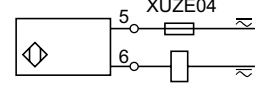

Dimensions

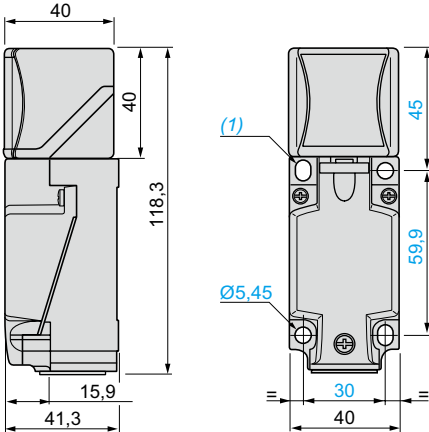

Head positions

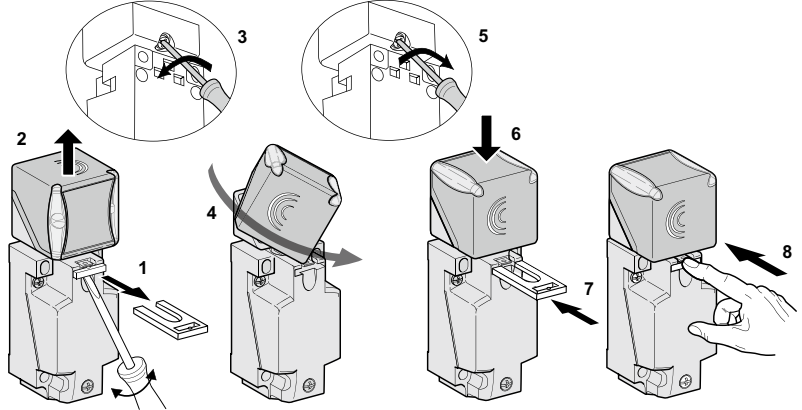

(1) 2 elongated holes $\varnothing 5.3 \times 7$ cm.

Tightening torque of cover fixing screws and clamp screws: $< 1.2 \text{ N.m} / < 10.62 \text{ lb-in}$

Example SIL 2 wiring scheme (with Preventa XPS MF40 safety PLC)

+ 24 V

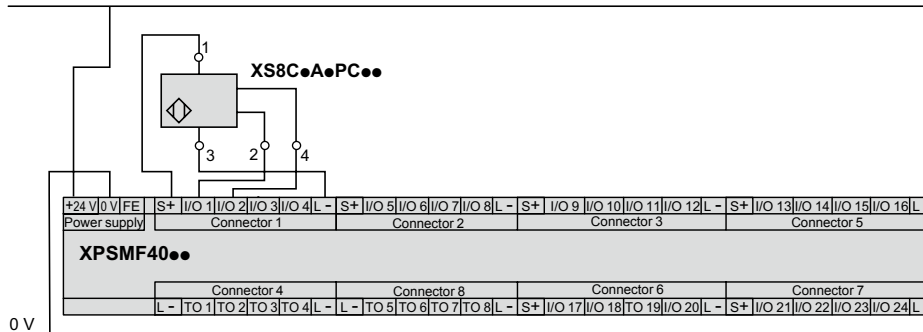

SFF (Safe Failure Fraction): 92,68 %
DC (Diagnosis Coverage): 75,8 %

S+: 24 V
L -: 0 V
I/O 1...24: safety I/O

Inductive proximity sensors

OsiSense XS Application

Sensors with analogue output signal 0...10 V ⁽¹⁾ or 4...20 mA. Plastic case, 40 x 40 mm front face
5 position turret head

Sensor	Non flush mountable in metal	
Dimensions	40 x 40 x 70 mm	40 x 40 x 117 mm

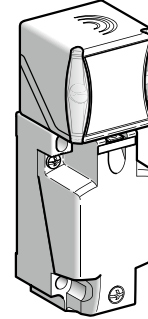
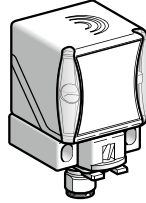

Nominal sensing distance (Sn)	25 mm
--------------------------------------	-------

References

3-wire	0...10 V output ⁽¹⁾	XS9C2A2A1M12	XS9C4A2A1P20 ⁽²⁾
2-wire	4...20 mA output	XS9C2A2A2M12	XS9C4A2A2P20 ⁽²⁾

XS9C4●●●P20 sensors are available with an ISO M20 cable entry and can be supplied with a PG 13.5 (e.g. **XS9C4A2A1G13**) or a 1/2" NPT (e.g. **XS9C4A2A2N12**) cable entry: please consult our Customer Care Centre for more information.

Weight (kg)	0.149	0.244
--------------------	-------	-------

Characteristics

Product certifications	UL, CSA, CE	
Conformity to standards	IEC 60947-5-2 and IEC 60947-5-7	
Connection	M12 connector (4-pin)	Screw terminals, clamping capacity 3 x 1.5 mm ² / 3 x 16 AWG
Operating zone	2...27 mm	
Linearity error	< 3%	
Repeat accuracy	< 3%	
Output current drift	< 5%	
Degree of protection	Conforming to IEC 60529 and DIN 40050	IP 65, IP 67 and IP 69K
Temperature	Storage	- 40...+ 85°C
	Operation ⁽³⁾	- 25...+ 70°C
Material	Case: PBT	
Vibration resistance	Conforming to IEC 60068-2-6	25 gn, amplitude ± 2 mm (f = 10...55 Hz)
Shock resistance	Conforming to IEC 60068-2-27	50 gn for 11 ms
Indicators	Output state (alignment aid)	Yellow LED
Rated supply voltage	4...20 mA	12...24 V with protection against reverse polarity
	0...10 V	24 V with protection against reverse polarity
Voltage limits (including ripple)	4...20 mA	12...36 V
	0...10 V	15...36 V
Current consumption, no-load	3-wire	< 4 mA
Delays	First-up	< 7 ms
	Response	< 6 ms
	Recovery	< 6 ms

Analogue outputs 4-20 mA and 0-10 V

XS9C2A2A2M12 and XS9C4A2A2P20	XS9C2A2A1M12 and XS9C4A2A1P20
--------------------------------------	--------------------------------------

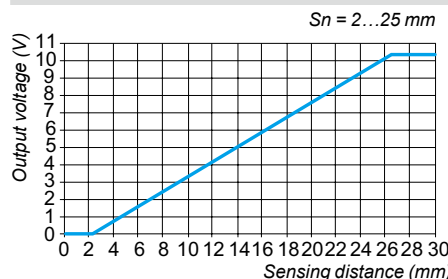
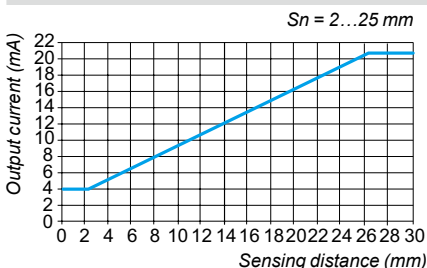

⁽¹⁾ Voltage range only obtained with a load impedance of 1000 Ω.

⁽²⁾ These sensors are supplied without a cable gland. An adaptable PG 13.5 cable gland is available (reference **XSZPE13**).

⁽³⁾ Sensors are available for very low temperatures (suffix **TF**: - 40°C, + 70°C) or very high temperatures (suffix **TT**: - 25°C, + 85°C); please consult our Customer Care Centre.

Inductive proximity sensors

OsiSense XS Application

Sensors with analogue output signal 0...10 V ⁽¹⁾ or 4...20 mA. Plastic case, 40 x 40 mm front face
5 position turret head

Setting-up precautions

Minimum mounting distances (mm)

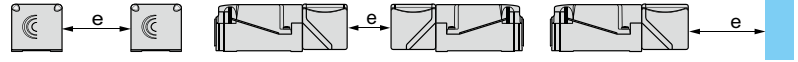

Side by side

Face to face

Facing a metal object

Sensors non flush mountable in metal

$e \geq 120$

$e \geq 240$

$e \geq 90$

Wiring schemes

2-wire

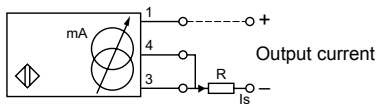

Output current Load impedance value

12 V	4...20 mA	$R \leq 82 \Omega$
24 V	4...20 mA	$R \leq 560 \Omega$

Ensure a minimum of 10 V between the + and the - (terminal 3) of the sensor.

3-wire

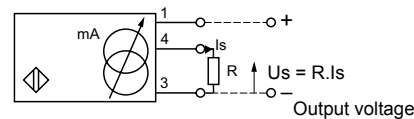

Output current Load impedance value Output voltage Load impedance value

12 V	0...10 mA	$R \leq 630 \Omega$	-	-
24 V	0...10 mA	$R \leq 1500 \Omega$	0...10 V	$R = 1000 \Omega$

Ensure a minimum of 5 V between the + and the sensor output (terminal 4).

Dimensions

XS9C2A2A1M12 and XS9C2A2A2M12

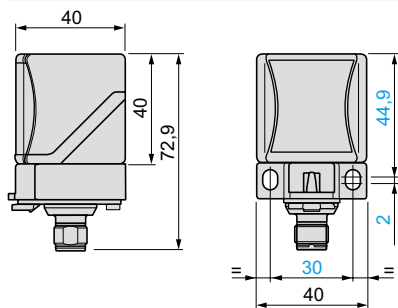

Head positions

XS9C2A2A1M12 and XS9C2A2A2M12

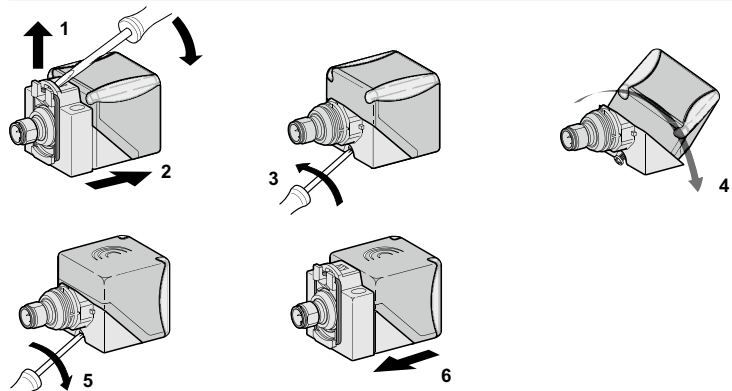

XS9C4A2A1P20 and XS9C4A2A2P20

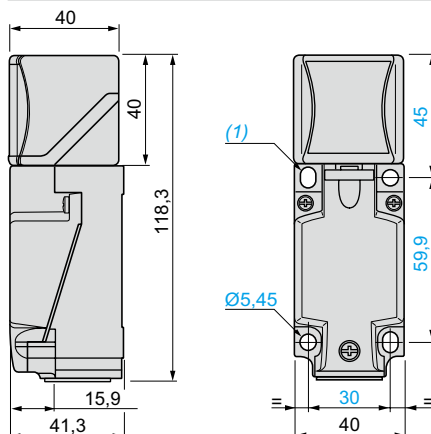

XS9C4A2A1P20 and XS9C4A2A2P20

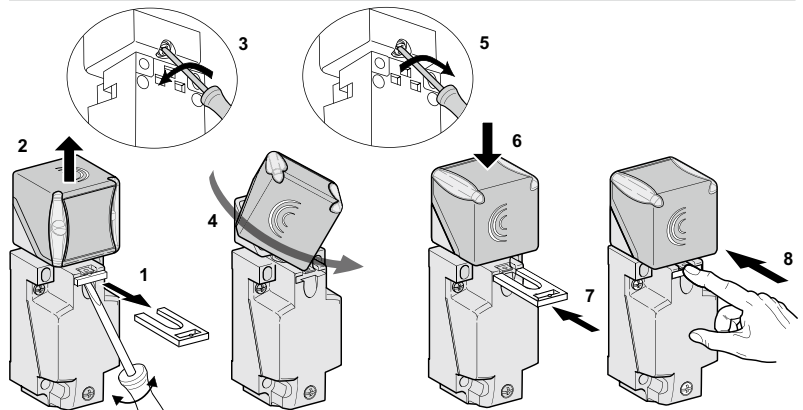

(1) 2 elongated holes $\varnothing 5.3 \times 7$ mm.

Tightening torque of cover fixing screws and clamp screws: $< 1.2 \text{ N.m} / < 10.62 \text{ lb-in}$

(1) Voltage range only obtained with a load impedance of 1000Ω .

Inductive proximity sensors

OsiSense XS Application

Factor 1 sensors for ferrous or non ferrous material detection and welding applications. Plastic case, 40 x 40 mm front face. 5 position turret head

Sensor	Flush mountable in metal	
Dimensions	40 x 40 x 70 mm	40 x 40 x 117 mm

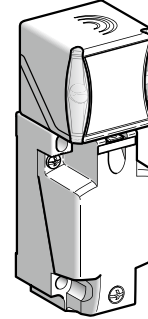
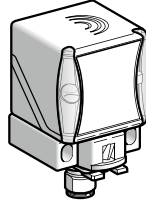

Nominal sensing distance (Sn)	20 mm
--------------------------------------	-------

References

4-wire ☐☐☐	PNP NO+NC	XS9C2A1PCM12	XS9C4A1PCP20 (1)
	NPN NO+NC	XS9C2A1NCM12	XS9C4A1NCP20 (1)

XS9C4●●●P20 sensors are available with an ISO M20 cable entry and can be supplied with a Pg 13.5 (e.g. **XS9C4A1PCG13**) or a 1/2" NPT (e.g. **XS9C4A1PCN12**) cable entry: please consult our Customer Care Centre for more information.

Weight (kg)	0.110	0.220
--------------------	-------	-------

Characteristics

Product certifications	UL, CSA, CE	
Conformity to standards	IEC 60947-5-2	
Connection	M12 connector (4-pin)	Screw terminals, clamping capacity 4 x 1.5 mm ² / 4 x 16 AWG
Operating zone	0...16 mm	
Differential travel	3...15% of Sr	
Repeat accuracy	< 3%	
Immunity to magnetic fields	< 250 mTesla	
Degree of protection	Conforming to IEC 60529 and DIN 40050	IP 65, IP 67 and IP 69K
Temperature	Storage	- 40...+ 85°C
	Operation (2)	- 25...+ 70°C
Material	Case: PBT	
Vibration resistance	Conforming to IEC 60068-2-6	25 gn, amplitude ± 2 mm (f = 10...55 Hz)
Shock resistance	Conforming to IEC 60068-2-27	50 gn for 11 ms
Indicators	Output state: yellow LED. Supply on: green LED	
Rated supply voltage	4-wire ☐☐☐	☐☐☐ 12...24 V with protection against reverse polarity
Voltage limits (including ripple)	4-wire ☐☐☐	☐☐☐ 10...36 V
Current consumption, no-load	4-wire ☐☐☐	< 30 mA
Switching capacity	4-wire ☐☐☐	< 200 mA with protection against overload and short-circuit
Voltage drop, closed state	4-wire ☐☐☐	< 2 V
Maximum switching frequency	4-wire ☐☐☐	250 Hz
Delays	First-up	< 15 ms
	Response	< 2.5 ms
	Recovery	< 2.5 ms

Setting-up

Sensing distance correction factor

SS: stainless steel, Fe: steel, Al: aluminium, Cu: copper.

Operating distance (according to the sensor's level of flush mounting)

--- : Flush mounted in Fe360 — : Flush mounted in aluminium

(1) These sensors are supplied without a cable gland. A suitable Pg 13.5 cable gland is available (reference **XSZPE13**).
 (2) Sensors are available for very low temperatures (suffix **TF**: - 40°C, + 70°C) or very high temperatures (suffix **TT**: - 25°C, + 85°C); please consult our Customer Care Centre.

Inductive proximity sensors

OsiSense XS Application

Factor 1 sensors for ferrous or non ferrous material detection and welding applications. Plastic case, 40 x 40 mm front face. 5 position turret head

Setting-up (continued)

Minimum mounting distances (mm)

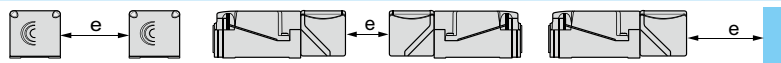

Side by side

Face to face

Facing a metal object

Sensors flush mountable in metal

$e \geq 80$

$e \geq 200$

$e \geq 60$

Wiring schemes

M12 connector



1: + V
2: NC Output
3: 0 V
4: NO Output

4-wire \overline{N} , NO + NC outputs

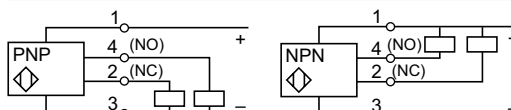

Accessories

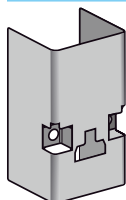

XSZPSC2

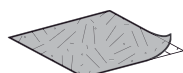

XSZPKC2

Description	Use for	Reference	Weight kg
Stainless steel rigid protective cover (only suitable for use when detecting from the top)	Welding	XSZPSC2	0.010
Protective sheet (for sensing face of sensor)	Welding	XSZPKC2	0.010

[Sold in lots of 5](#)

Dimensions

XS9C2A1PCM12 and XS9C2A1NCM12

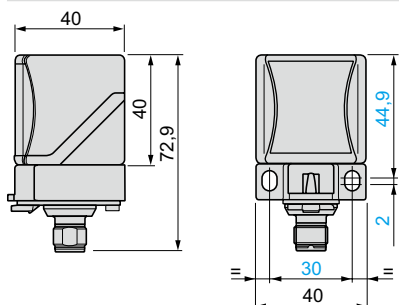

Head positions

XS9C2A1PCM12 and XS9C2A1NCM12

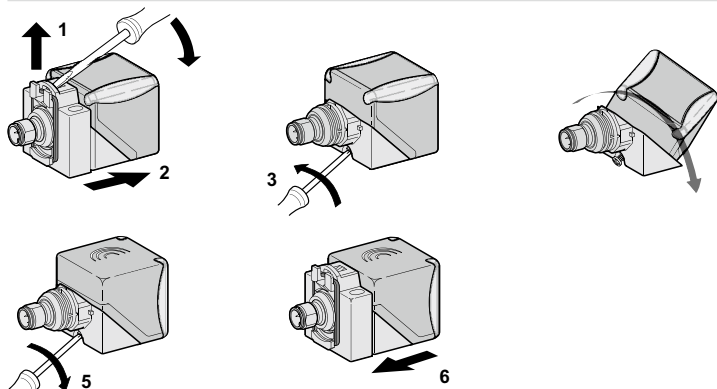

XS9C4A1PCP20 and XS9C4A1NCP20

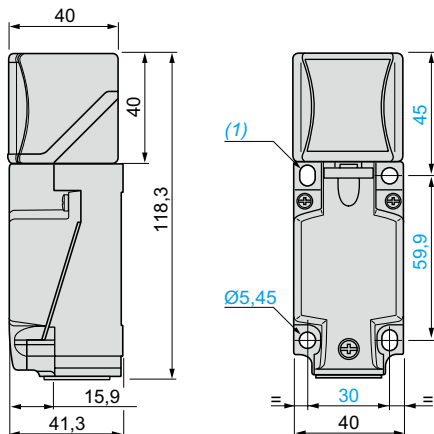

XS9C4A1PCP20 and XS9C4A1NCP20

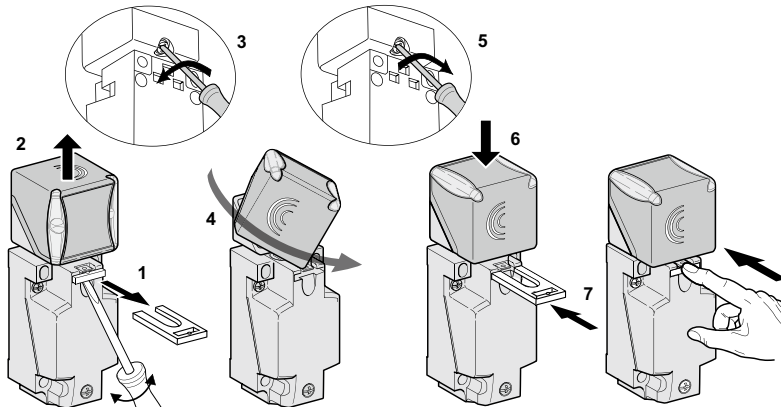

(1) 2 elongated holes $\varnothing 5.3 \times 7$ mm.

Tightening torque of cover fixing screws and clamp screws: $< 1.2 \text{ N.m} / < 10.62 \text{ lb-in}$.

X	
XS7C2A1DAM12	4
XS7C2A1DBM12	4
XS7C2A1MAU20	4
XS7C2A1MBU20	4
XS7C2A1NAM12	4
XS7C2A1NBM12	4
XS7C2A1PAM12	4
XS7C2A1PBM12	4
XS7C4A1DPP20	6
XS7C4A1MPP20	6
XS8C2A1DAM12	4
XS8C2A1DBM12	4
XS8C2A1MAU20	4
XS8C2A1MBU20	4
XS8C2A1NCM12	4
XS8C2A1PCM12	4
XS8C2A4DAM12	4
XS8C2A4DBM12	4
XS8C2A4MAU20	4
XS8C2A4MBU20	4
XS8C2A4NCM12	4
XS8C2A4PCM12	4
XS8C4A1DPP20	6
XS8C4A1MPP20	6
XS8C4A1NCP20	6
XS8C4A1PCP20	6
XS8C4A4DPP20	6
XS8C4A4MPP20	6
XS8C4A4NCP20	6
XS8C4A4PCP20	6
XS9C2A1NCM12	10
XS9C2A1PCM12	10
XS9C2A2A1M12	8
XS9C2A2A2M12	8
XS9C4A1NCP20	10
XS9C4A1PCP20	10
XS9C4A2A1P20	8
XS9C4A2A2P20	8
XSZPKC2	11
XSZPSC2	11
XZCP1141L2	5
XZCP1141L5	5
XZCP1141L10	5
XZCP1241L2	5
XZCP1241L5	5
XZCP1241L10	5
XZCP1865L5	5
XZCP1865L10	5
XZCP1965L5	5
XZCP1965L10	5

Schneider Electric Industries SAS

Head Office
35, rue Joseph Monier
F-92500 Rueil-Malmaison
France

www.tesensors.com

The information provided in this documentation contains general descriptions and/or technical characteristics of the performance of the products contained herein. This documentation is not intended as a substitute for and is not to be used for determining suitability or reliability of these products for specific user applications. It is the duty of any such user or integrator to perform the appropriate and complete risk analysis, evaluation and testing of the products with respect to the relevant specific application or use thereof. Neither Schneider Electric nor any of its affiliates or subsidiaries shall be responsible or liable for misuse of the information contained herein.

Design: Schneider Electric
Photos: Schneider Electric